



**February 2011**  
**GSM Design Library**

© **Agilent Technologies, Inc. 2000-2011**

5301 Stevens Creek Blvd., Santa Clara, CA 95052 USA

No part of this documentation may be reproduced in any form or by any means (including electronic storage and retrieval or translation into a foreign language) without prior agreement and written consent from Agilent Technologies, Inc. as governed by United States and international copyright laws.

**Acknowledgments**

Mentor Graphics is a trademark of Mentor Graphics Corporation in the U.S. and other countries. Mentor products and processes are registered trademarks of Mentor Graphics Corporation. \* Calibre is a trademark of Mentor Graphics Corporation in the US and other countries. "Microsoft®, Windows®, MS Windows®, Windows NT®, Windows 2000® and Windows Internet Explorer® are U.S. registered trademarks of Microsoft Corporation. Pentium® is a U.S. registered trademark of Intel Corporation. PostScript® and Acrobat® are trademarks of Adobe Systems Incorporated. UNIX® is a registered trademark of the Open Group. Oracle and Java and registered trademarks of Oracle and/or its affiliates. Other names may be trademarks of their respective owners. SystemC® is a registered trademark of Open SystemC Initiative, Inc. in the United States and other countries and is used with permission. MATLAB® is a U.S. registered trademark of The Math Works, Inc.. HiSIM2 source code, and all copyrights, trade secrets or other intellectual property rights in and to the source code in its entirety, is owned by Hiroshima University and STARC. FLEXIm is a trademark of Globetrotter Software, Incorporated. Layout Boolean Engine by Klaas Holwerda, v1.7 <http://www.xs4all.nl/~kholwerd/bool.html> . FreeType Project, Copyright (c) 1996-1999 by David Turner, Robert Wilhelm, and Werner Lemberg. QuestAgent search engine (c) 2000-2002, JObjects. Motif is a trademark of the Open Software Foundation. Netscape is a trademark of Netscape Communications Corporation. Netscape Portable Runtime (NSPR), Copyright (c) 1998-2003 The Mozilla Organization. A copy of the Mozilla Public License is at <http://www.mozilla.org/MPL/> . FFTW, The Fastest Fourier Transform in the West, Copyright (c) 1997-1999 Massachusetts Institute of Technology. All rights reserved.

The following third-party libraries are used by the NlogN Momentum solver:

"This program includes Metis 4.0, Copyright © 1998, Regents of the University of Minnesota", <http://www.cs.umn.edu/~metis> , METIS was written by George Karypis (karypis@cs.umn.edu).

Intel@ Math Kernel Library, <http://www.intel.com/software/products/mkl>

SuperLU\_MT version 2.0 - Copyright © 2003, The Regents of the University of California, through Lawrence Berkeley National Laboratory (subject to receipt of any required approvals from U.S. Dept. of Energy). All rights reserved. SuperLU Disclaimer: THIS SOFTWARE IS PROVIDED BY THE COPYRIGHT HOLDERS AND CONTRIBUTORS "AS IS" AND ANY EXPRESS OR IMPLIED WARRANTIES, INCLUDING, BUT NOT LIMITED TO, THE IMPLIED WARRANTIES OF MERCHANTABILITY AND FITNESS FOR A PARTICULAR PURPOSE ARE DISCLAIMED. IN NO EVENT SHALL THE COPYRIGHT OWNER OR CONTRIBUTORS BE LIABLE FOR ANY DIRECT, INDIRECT, INCIDENTAL, SPECIAL, EXEMPLARY, OR CONSEQUENTIAL DAMAGES (INCLUDING, BUT NOT LIMITED TO, PROCUREMENT OF SUBSTITUTE GOODS OR SERVICES; LOSS OF USE, DATA, OR PROFITS; OR BUSINESS INTERRUPTION) HOWEVER CAUSED AND ON ANY THEORY OF LIABILITY, WHETHER IN

CONTRACT, STRICT LIABILITY, OR TORT (INCLUDING NEGLIGENCE OR OTHERWISE) ARISING IN ANY WAY OUT OF THE USE OF THIS SOFTWARE, EVEN IF ADVISED OF THE POSSIBILITY OF SUCH DAMAGE.

7-zip - 7-Zip Copyright: Copyright (C) 1999-2009 Igor Pavlov. Licenses for files are: 7z.dll: GNU LGPL + unRAR restriction, All other files: GNU LGPL. 7-zip License: This library is free software; you can redistribute it and/or modify it under the terms of the GNU Lesser General Public License as published by the Free Software Foundation; either version 2.1 of the License, or (at your option) any later version. This library is distributed in the hope that it will be useful, but WITHOUT ANY WARRANTY; without even the implied warranty of MERCHANTABILITY or FITNESS FOR A PARTICULAR PURPOSE. See the GNU Lesser General Public License for more details. You should have received a copy of the GNU Lesser General Public License along with this library; if not, write to the Free Software Foundation, Inc., 59 Temple Place, Suite 330, Boston, MA 02111-1307 USA. unRAR copyright: The decompression engine for RAR archives was developed using source code of unRAR program. All copyrights to original unRAR code are owned by Alexander Roshal. unRAR License: The unRAR sources cannot be used to re-create the RAR compression algorithm, which is proprietary. Distribution of modified unRAR sources in separate form or as a part of other software is permitted, provided that it is clearly stated in the documentation and source comments that the code may not be used to develop a RAR (WinRAR) compatible archiver. 7-zip Availability: <http://www.7-zip.org/>

AMD Version 2.2 - AMD Notice: The AMD code was modified. Used by permission. AMD copyright: AMD Version 2.2, Copyright © 2007 by Timothy A. Davis, Patrick R. Amestoy, and Iain S. Duff. All Rights Reserved. AMD License: Your use or distribution of AMD or any modified version of AMD implies that you agree to this License. This library is free software; you can redistribute it and/or modify it under the terms of the GNU Lesser General Public License as published by the Free Software Foundation; either version 2.1 of the License, or (at your option) any later version. This library is distributed in the hope that it will be useful, but WITHOUT ANY WARRANTY; without even the implied warranty of MERCHANTABILITY or FITNESS FOR A PARTICULAR PURPOSE. See the GNU Lesser General Public License for more details. You should have received a copy of the GNU Lesser General Public License along with this library; if not, write to the Free Software Foundation, Inc., 51 Franklin St, Fifth Floor, Boston, MA 02110-1301 USA Permission is hereby granted to use or copy this program under the terms of the GNU LGPL, provided that the Copyright, this License, and the Availability of the original version is retained on all copies. User documentation of any code that uses this code or any modified version of this code must cite the Copyright, this License, the Availability note, and "Used by permission." Permission to modify the code and to distribute modified code is granted, provided the Copyright, this License, and the Availability note are retained, and a notice that the code was modified is included. AMD Availability: <http://www.cise.ufl.edu/research/sparse/amd>

UMFPACK 5.0.2 - UMFPACK Notice: The UMFPACK code was modified. Used by permission. UMFPACK Copyright: UMFPACK Copyright © 1995-2006 by Timothy A. Davis. All Rights Reserved. UMFPACK License: Your use or distribution of UMFPACK or any modified version of UMFPACK implies that you agree to this License. This library is free software; you can redistribute it and/or modify it under the terms of the GNU Lesser General Public License as published by the Free Software Foundation; either version 2.1 of the License, or (at your option) any later version. This library is distributed in the hope that it will be useful, but WITHOUT ANY WARRANTY; without even the implied warranty of MERCHANTABILITY

or FITNESS FOR A PARTICULAR PURPOSE. See the GNU Lesser General Public License for more details. You should have received a copy of the GNU Lesser General Public License along with this library; if not, write to the Free Software Foundation, Inc., 51 Franklin St, Fifth Floor, Boston, MA 02110-1301 USA Permission is hereby granted to use or copy this program under the terms of the GNU LGPL, provided that the Copyright, this License, and the Availability of the original version is retained on all copies. User documentation of any code that uses this code or any modified version of this code must cite the Copyright, this License, the Availability note, and "Used by permission." Permission to modify the code and to distribute modified code is granted, provided the Copyright, this License, and the Availability note are retained, and a notice that the code was modified is included. UMFPACK Availability: <http://www.cise.ufl.edu/research/sparse/umfpack> UMFPACK (including versions 2.2.1 and earlier, in FORTRAN) is available at <http://www.cise.ufl.edu/research/sparse> . MA38 is available in the Harwell Subroutine Library. This version of UMFPACK includes a modified form of COLAMD Version 2.0, originally released on Jan. 31, 2000, also available at <http://www.cise.ufl.edu/research/sparse> . COLAMD V2.0 is also incorporated as a built-in function in MATLAB version 6.1, by The MathWorks, Inc. <http://www.mathworks.com> . COLAMD V1.0 appears as a column-preordering in SuperLU (SuperLU is available at <http://www.netlib.org> ). UMFPACK v4.0 is a built-in routine in MATLAB 6.5. UMFPACK v4.3 is a built-in routine in MATLAB 7.1.

Qt Version 4.6.3 - Qt Notice: The Qt code was modified. Used by permission. Qt copyright: Qt Version 4.6.3, Copyright (c) 2010 by Nokia Corporation. All Rights Reserved. Qt License: Your use or distribution of Qt or any modified version of Qt implies that you agree to this License. This library is free software; you can redistribute it and/or modify it under the terms of the GNU Lesser General Public License as published by the Free Software Foundation; either version 2.1 of the License, or (at your option) any later version. This library is distributed in the hope that it will be useful, but WITHOUT ANY WARRANTY; without even the implied warranty of MERCHANTABILITY or FITNESS FOR A PARTICULAR PURPOSE. See the GNU Lesser General Public License for more details. You should have received a copy of the GNU Lesser General Public License along with this library; if not, write to the Free Software Foundation, Inc., 51 Franklin St, Fifth Floor, Boston, MA 02110-1301 USA Permission is hereby granted to use or copy this program under the terms of the GNU LGPL, provided that the Copyright, this License, and the Availability of the original version is retained on all copies. User documentation of any code that uses this code or any modified version of this code must cite the Copyright, this License, the Availability note, and "Used by permission." Permission to modify the code and to distribute modified code is granted, provided the Copyright, this License, and the Availability note are retained, and a notice that the code was modified is included. Qt Availability: <http://www.qtsoftware.com/downloads> Patches Applied to Qt can be found in the installation at: `$(HPEESOF_DIR)/prod/licenses/thirdparty/qt/patches`. You may also contact Brian Buchanan at Agilent Inc. at [brian\\_buchanan@agilent.com](mailto:brian_buchanan@agilent.com) for more information.

The HiSIM\_HV source code, and all copyrights, trade secrets or other intellectual property rights in and to the source code, is owned by Hiroshima University and/or STARC.

**Errata** The ADS product may contain references to "HP" or "HPEESOF" such as in file names and directory names. The business entity formerly known as "HP EESof" is now part of Agilent Technologies and is known as "Agilent EEsof". To avoid broken functionality and

to maintain backward compatibility for our customers, we did not change all the names and labels that contain "HP" or "HPEESOF" references.

**Warranty** The material contained in this document is provided "as is", and is subject to being changed, without notice, in future editions. Further, to the maximum extent permitted by applicable law, Agilent disclaims all warranties, either express or implied, with regard to this documentation and any information contained herein, including but not limited to the implied warranties of merchantability and fitness for a particular purpose. Agilent shall not be liable for errors or for incidental or consequential damages in connection with the furnishing, use, or performance of this document or of any information contained herein. Should Agilent and the user have a separate written agreement with warranty terms covering the material in this document that conflict with these terms, the warranty terms in the separate agreement shall control.

**Technology Licenses** The hardware and/or software described in this document are furnished under a license and may be used or copied only in accordance with the terms of such license. Portions of this product include the SystemC software licensed under Open Source terms, which are available for download at <http://systemc.org/> . This software is redistributed by Agilent. The Contributors of the SystemC software provide this software "as is" and offer no warranty of any kind, express or implied, including without limitation warranties or conditions or title and non-infringement, and implied warranties or conditions merchantability and fitness for a particular purpose. Contributors shall not be liable for any damages of any kind including without limitation direct, indirect, special, incidental and consequential damages, such as lost profits. Any provisions that differ from this disclaimer are offered by Agilent only.

**Restricted Rights Legend** U.S. Government Restricted Rights. Software and technical data rights granted to the federal government include only those rights customarily provided to end user customers. Agilent provides this customary commercial license in Software and technical data pursuant to FAR 12.211 (Technical Data) and 12.212 (Computer Software) and, for the Department of Defense, DFARS 252.227-7015 (Technical Data - Commercial Items) and DFARS 227.7202-3 (Rights in Commercial Computer Software or Computer Software Documentation).

About GSM Design Library	9
Introduction	10
Overview of Component Libraries	11
Glossary of Terms	22
References	23
Channel Coding Components for GSM Design Library	24
GSM_BlockCodeRACH	25
GSM_CC_WithTail	26
GSM_Combiner	28
GSM_CycDecoder	29
GSM_CycEncoder	32
GSM_DCC_WithTail	34
GSM_Deinterleaver_4	36
GSM_Deinterleaver_8	37
GSM_Deinterleaver_F96	38
GSM_Depuncture	39
GSM_FACCH_Decoder	40
GSM_FACCH_Encoder	42
GSM_FireDecoder	44
GSM_Interleaver_4	46
GSM_Interleaver_8	48
GSM_Interleaver_F96	50
GSM_InverseReord	52
GSM_Puncture	53
GSM_RACH_Decoder	54
GSM_RACH_Encoder	56
GSM_Reorder	58
GSM_RmvStlFlgs	59
GSM_SACCH_Decoder	60
GSM_SACCH_Encoder	62
GSM_SCH_Decoder	64
GSM_SCH_Encoder	65
GSM_Splitter	66
GSM_TailBits	67
GSM_TCHF24_Decoder	68
GSM_TCHF24_Encoder	69
GSM_TCHF48_Decoder	71
GSM_TCHF48_Encoder	72
GSM_TCHF96_Decoder	74
GSM_TCHF96_Encoder	75
GSM_TCHFS_Decoder	77
GSM_TCHFS_Encoder	79
Equalization Components for GSM Design Library	81
GSM_ChannelEstimator	82
GSM_Derotator	84
GSM_Equalizer	85
GSM_EquCombiner	87
GSM_EquComposeAB	89
GSM_EquDecomposeAB	91
GSM_EquSplitter	93
GSM_Filter	95

GSM_Receiver	96
GSM_ReceiverAB	98
Framing Components for GSM Design Library	100
GSM_AccessBurst	101
GSM_BcchCcch4SdcchDn	102
GSM_BcchCcch4SdcchUp	104
GSM_BcchCcchDn	106
GSM_BcchCcchUp	108
GSM_DeAccessBurst	109
GSM_DeBcchCcch4SdcchDn	110
GSM_DeBcchCcch4SdcchUp	112
GSM_DeBcchCcchDn	114
GSM_DeMultiframe26	116
GSM_DeNormalBurst	118
GSM_DeSBurst	119
GSM_DeSdcch8Dn	120
GSM_DeSdcch8Up	122
GSM_DeTDMA	124
GSM_DummyBurst	126
GSM_FBurst	127
GSM_Multiframe26	129
GSM_NormalBurst	131
GSM_SBurst	133
GSM_Sdcch8Dn	135
GSM_Sdcch8Up	137
GSM_TDMA	139
GSM_TimeBaseCounter	141
GSM Design Examples	143
Error Distribution Analysis of Adaptive Equalizer in Normal Burst	144
Fast Associated Control Channel	147
GMSK Modulation Spectrum	151
GSM Speech Codec	155
GSM Traffic Channel Full Rate Speech Measurement	159
Random Access Channel	165
Slow Associated Control Channel	168
Synchronization Channel	172
Traffic Channel for Data Transmission at 2.4 kbps	176
Traffic Channel for Data Transmission at 4.8 kbps	180
Traffic Channel for Data Transmission at 9.6 kbps	184
Channel Codec for TCH/FS	190
Transmission and Reception of Traffic Channel/Full-Rate Speech	194
Measurement Components for GSM Design Library	198
GSM_BerFer	199
GSM_ErrPatternDisplay	200
Modem Components	201
GSM_AQuarterBitAdd	202
GSM_AQuarterBitRmv	204
GSM_Carrier	206
GSM_DifferDecoder	208
GSM_DifferEncoder	209
GSM_GMSKDemod	210

GSM_GMSKMod	212
GSM_MpyClock	214
GSM_Rom	215
Speech Codec Components	217
GSM_APCM_Quantizer	218
GSM_Autocorrelation	220
GSM_CodeLAR	221
GSM_DecodeLAR	223
GSM_Deemphasis	225
GSM_Deframing	226
GSM_Framing	228
GSM_Interpolation	230
GSM_InverseAPCM	232
GSM_LARToRefCoe	233
GSM_LogAreaRatio	234
GSM_LongTermAnalysis	235
GSM_LongTermSynthesis	237
GSM_LTP_Parameter	239
GSM_OffsetCompensation	241
GSM_Postprocessing	243
GSM_Preamphasis	244
GSM_ReadFile	245
GSM_RPE_GridPosition	246
GSM_RPE_GridSelection	248
GSM_ScaleInput	250
GSM_Schur	251
GSM_ShortTermAnalysis	252
GSM_ShortTermPredict	254
GSM_ShortTermSynthesis	256
GSM_SpeechDecoder	258
GSM_SpeechEncoder	260
GSM_WeightingFilter	263
GSM_WriteFile	265
Synchronization Components for GSM Design Library	266
GSM_DataSelection	267
GSM_PhaseRecovery	269
GSM_PhsRcvryTrNoMod	270
GSM_Sampler	271
GSM_SynABurst	272
GSM_SynNBurst	275
GSM_SynNBurstTrNoMod	277
GSM_SynSBurst	279
GSM_TrainBitGen	281



# About GSM Design Library

## Introduction

GSM, the Global System for Mobile Communication, is a digital cellular radio system for public land mobile network (PLMN).

The GSM communication system is an important wireless system for the second-generation mobile communication. The GSM Design Library provides models that enable end-to-end system modeling and simulation for the physical layer of GSM systems. These models are intended to be a baseline system for designers to get an idea of what a nominal of ideal system performance would be. They also can help the researchers in this field or GSM system designers to achieve their designs and improve their work efficiency.

The GSM Design Library includes key features of the GSM system in physical layer, for example RPE-LTP speech codec, channel coding and interleaving (for channels such as TCH/FS, SACCH, RACH, SCH), burst assembly, GMSK modulation and demodulation, bit synchronization, equalization, and FER and BER measurement.

The GSM example designs that are shipped with the GSM Design Library software, including schematics, test conditions, and simulation results, are described in *GSM Design Examples (gsm)*.

## Overview of Component Libraries

The GSM Design Library includes more than 100 behavioral models and subnetworks that are organized by their functions in seven libraries:

- Speech Codec is part of the GSM system that provides the basic models required by ETSI GSM 06.10, in which the specified transcoding procedure is applicable for the full-rate traffic channel.
- Channel Coding includes cyclic codes encoder, cyclic codes decoder, reorder, Fire codes encoder and decoder, interleavers and de-interleavers per GSM specification. With these models, 13 kinds of GSM channels can be set up: TCH/FS, TCH/F9.6, TCH/F4.8, TCH/F2.4, SACCH, BCCH, PCH, AGCH, CBCH, SDCCH, FACCH, RACH, and SCH.
- Equalization includes derotator, splitter (splits one burst into two specific frames for bidirectional equalization), combiner (combines the two input frames into one burst after bidirectional equalization), channel estimator, matched filter and equalizer.
- Framing includes bursts, time slots, TDMA frames, multiframe composing and de-composing.
- Measurement includes BER and FER measurement models.
- Modem includes GMSK modulation and demodulation (differential encoding and decoding, Rom for I, Q branch signal).
- Synchronization includes data selection, phase recovery, and downsampler.

Twenty-nine sub-networks speed system construction, such as GMSK modulation, synchronization, receiver.

These models and sub-networks are implemented according to ETSI GSM specification.

TCH/FS example in [Block Diagram of GSM TCH/FS System Simulation](#) shows the system simulation structure. After speech codec, data is split by two splitters; the Ia part is cyclic encoded and the Ib part (132 bits) is not cyclic encoded. The combined Ia and Ib are the most critical bits that use half-rate convolutional coding after tail bits are added. Combined with the 78 part II bits, data (entire block length is 456 bits) is fed into the diagonal interleaver that enhances the error correction capability if a sequence of TDMA frames is corrupted during radio transmission. The interleaver output is sent to a burst assembly model (for example, normal burst).

In the reception side, bit synchronization and MLSE receiver are used to recover encoded data. The BER and FER can be determined after comparing input and output data of the system.

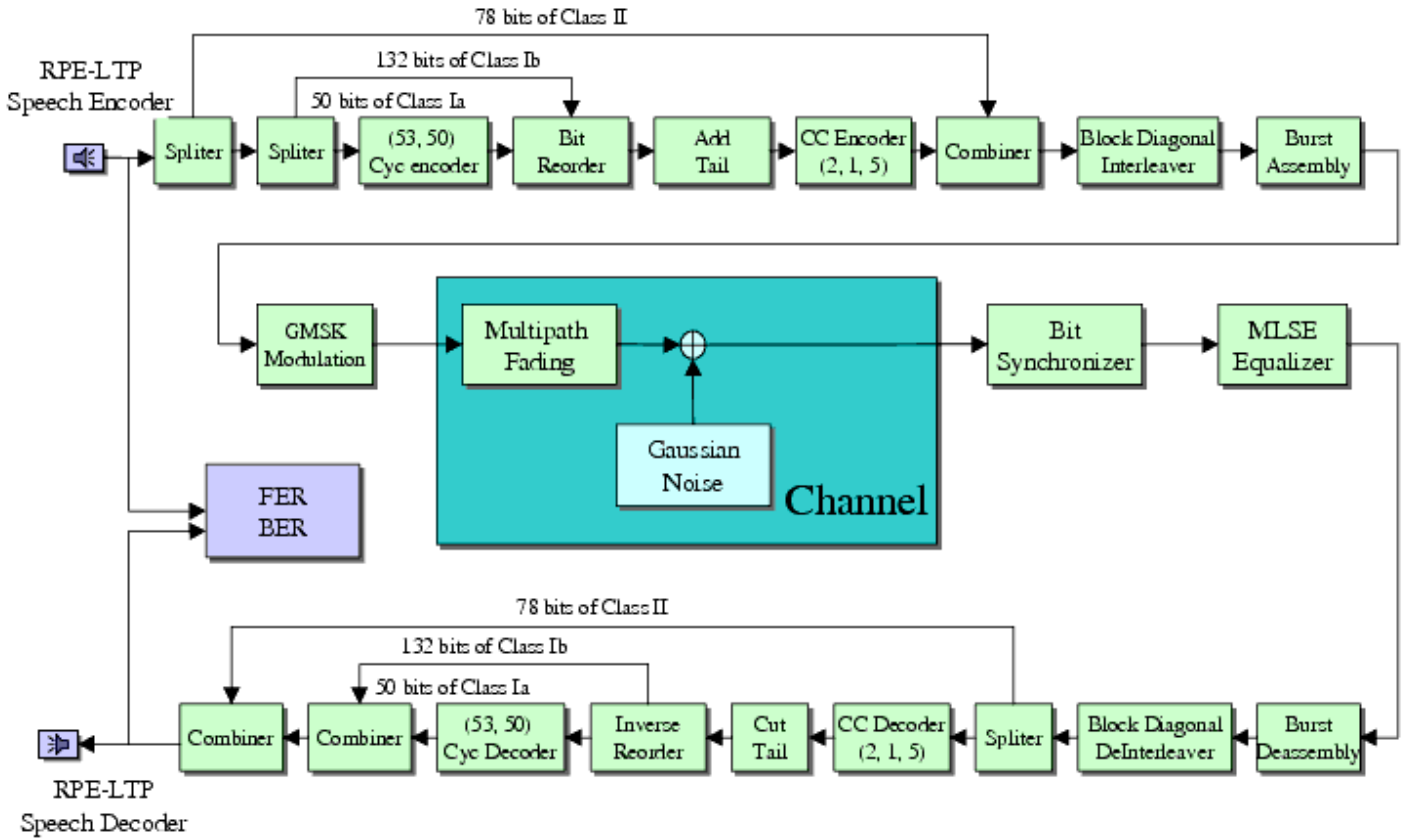

Block Diagram of GSM TCH/FS System Simulation

## Channel Coding

There are 13 channel types. The relationship between the channels and the modules are shown in [Channel Coding Modules](#).

### Channel Coding Modules

Channel Type	Block Codec	Convolutional Codec †	Interleaving, Deinterleaving
TCH/FS	cyc_encoder, cyc_decoder, tailbits, reorder, inverse reorder, splitter, combiner	cc(2,1,5)	interleaver_8, deinterleaver_8, (block diagonal interleaver) Get_stealing_flag
TCH/F96	tailbits	punctured cc(2,1,5)	interleaver_f96, deinterleaver_f96, (diagonal interleaver) Get_stealing_flag
TCH/F48	tailbits	cc(3,1,5)	interleaver_f96, deinterleaver_f96, (diagonal interleaver) Get_stealing_flag
TCH/F24	tailbits	cc(6,1,5)	interleaver_8, deinterleaver_8, (block diagonal interleaver) Get_stealing_flag
SACCH, BCCH, PCH, AGCH, CBCH and SDCCH	cyc_encoder, Fire_decoder, tailbits	cc(2,1,5)	interleaver_4, deinterleaver_4, (block rectangular interleaver) Get_stealing_flag
FACCH	cyc_encoder, Fire_decoder, tailbits	cc(2,1,5)	interleaver_8, deinterleaver_8, (block diagonal interleaver) Get_stealing_flag
RACH	cyc_encoder, cyc_decoder, blockcode_RACH, tailbits	cc(2,1,5)	(no interleaver)
SCH	cyc_encoder, cyc_decoder, tailbits	cc(2,1,5)	(no interleaver)

† cc(2,1,5) means convolutional code with rate  $r = 1/2$  and constraint length  $K=5$

Channels are defined by the different frame structures which consists of bursts. Channels can be divided into traffic channels and control channels. Control channels include:

- Dedicated channels such as SDCCH, SACCH, FACCH
- Broadcast channels such as FCCH, SCH, BCCH
- Common control channels such as PCH, AGCH, RACH

Channels can have several combinations; each channel combination requires one single physical channel. Full rate channel combinations are:

- TCH/FS+SACCH/FS
- FCCH+SCH+CCCH+BCCH;
- FCCH+SCH+CCCH+BCCH+SDCCH/4+SACCH/4
- CCCH+BCCH
- SDCCH/8+SACCH/8

[Time Frames, Time Slots and Bursts](#) shows the relationship of time frames, time slots and bursts.

1 hyperframe = 2048 superframes = 2 715 648 TDMA frames (3 h 28 m 53 s 780 ms)

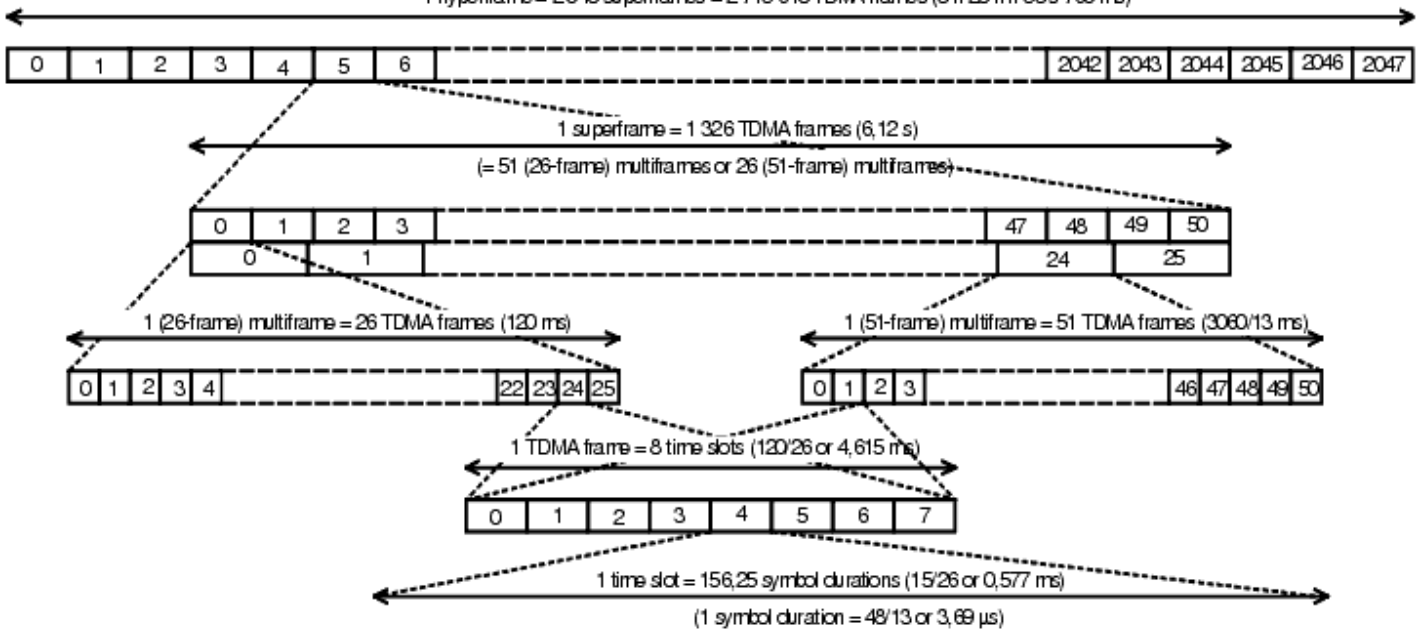

(TB: Tail bits - GP: Guard period)

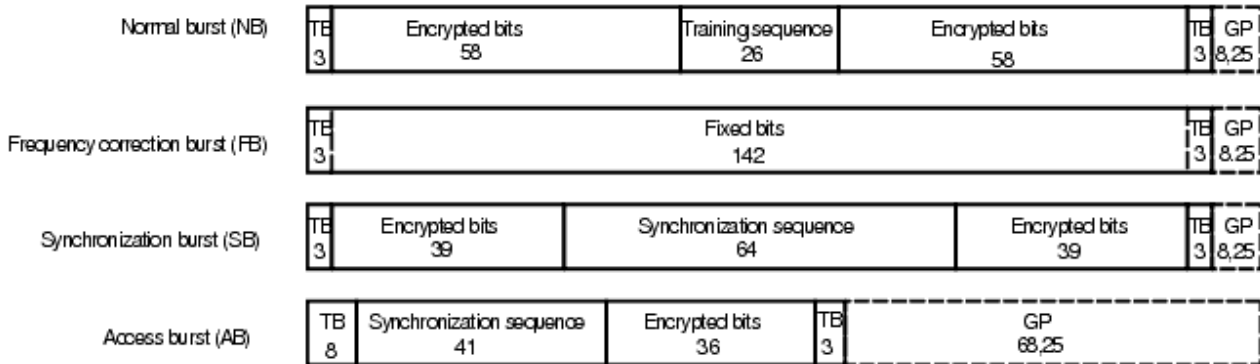

### Time Frames, Time Slots and Bursts

## Equalization

The equalizer is based on the paper by G. Ungerboeck [19]. Maximum-likelihood sequence estimation and a modified version of Viterbi algorithm are used. The algorithm operates directly on the output signal of a complex matched filter, taking into account the correlation of (non-whitened) noise samples. The Ungerboeck receiver has several advantages:

- Only the matched filter is required before the Viterbi processor.
- Metric computation in the modified Viterbi algorithm does not require any squaring operation.
- It can be implemented in an all-digital form, including the functions needed for adaptation.

The two working modes of the equalizer are: training and tracking.

In the training mode, a new estimate of the channel impulse response (CIR) is obtained at each received burst by correlating the received signal with the training sequence that is known at the receiver. The CIR estimate is truncated at N samples by considering the N bit time span where the maximum energy is concentrated. The matched filter tap gains can then be directly set as the complex conjugates of the estimated CIR coefficients.

In the tracking mode, the matched filter establishes an optimum signal-to-noise ratio, and the Viterbi processor eliminates the intersymbol interference using the modified Viterbi algorithm. Channel variations are compensated by adjusting the matched filter tap gains and the Viterbi processor parameters. These are adjusted using a gradient algorithm to minimize the mean-square error.

According to the structure of the GSM bursts (normal and synchronization bursts), that is, the training sequence is in the middle of the burst, the equalizer works forward from the beginning of the training sequence to the end of the burst, and backward from the end of the training sequence to the beginning of the burst, as shown in [Bidirectional Equalization on Normal Burst](#).

Two equalizers work on the same burst simultaneously; their outputs will be ordered to form the estimated burst. Because the training sequence is equalized twice, only one of the estimated training sequences is embedded in the resulting burst.

The structure of the Viterbi adaptive receiver is shown in [Block Diagram of Viterbi Adaptive Receiver](#).

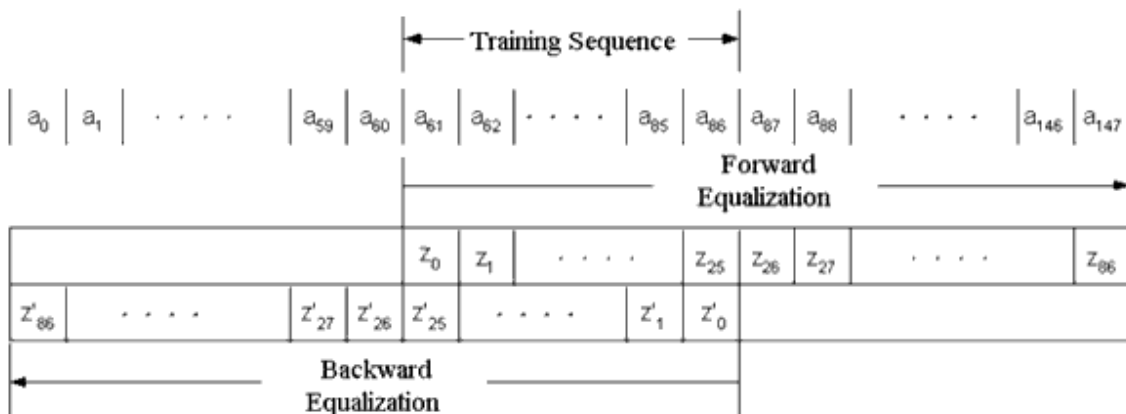

**Bidirectional Equalization on Normal Burst**

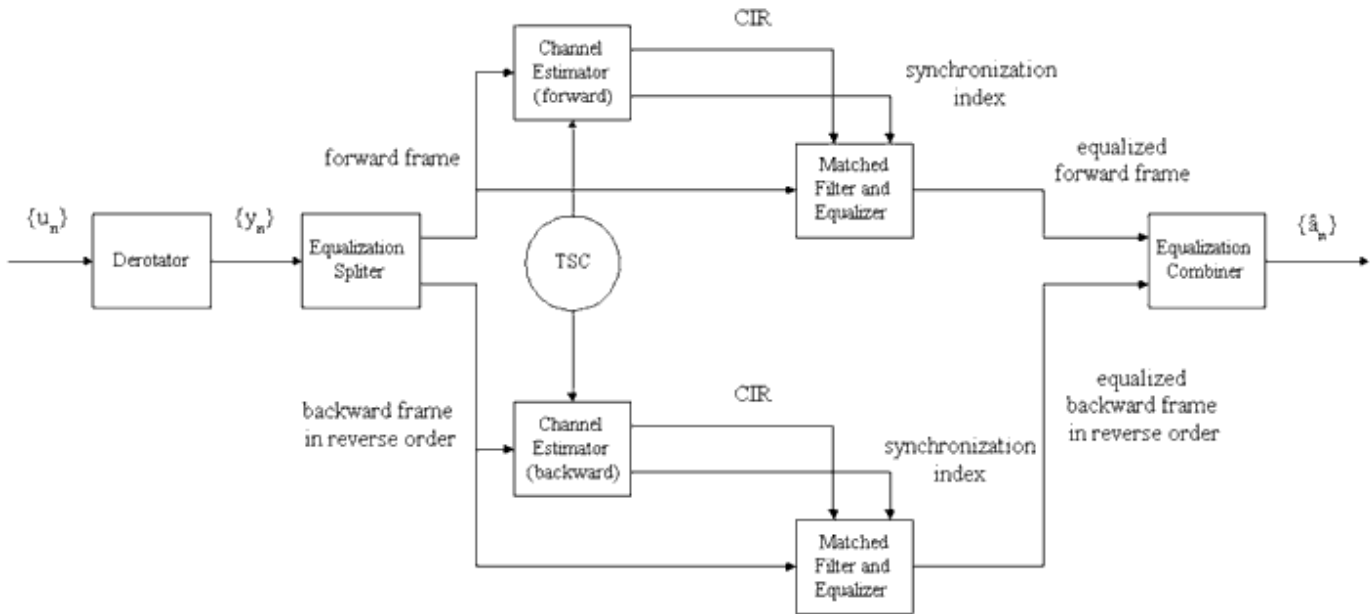

**Block Diagram of Viterbi Adaptive Receiver**

## Framing and Deframing

These models are used in GSM multiplexing and multiple access on the radio path. The physical channels of the radio sub-system, required to support the logical channels according to GSM 05.02, are defined. Bursts, time slots, TDMA frames, multiframe assembly and disassembly are included.

## Multiple Access and Channel Structure

Since radio spectrum is a limited resource shared by all users, the bandwidth is divided among as many users as possible. GSM uses a combination of time- and frequency-division multiple access (TDMA/FDMA).

FDMA involves the division by frequency of the (maximum) 25 MHz bandwidth into 124 carrier frequencies spaced 200 kHz apart. One or more carrier frequencies are assigned to each base station. Each carrier frequency is then divided in time, using a TDMA scheme. The fundamental unit of time in the TDMA scheme is called a burst period that lasts 15/26 msec (or approximately 0.577 msec). Eight burst periods are grouped in a TDMA frame (120/26 msec, or approximately 4.615 msec).

## Burst Structure



Five different types of bursts are used for transmission in GSM. The normal burst is used to carry data and most signaling. It has a total length of 156.25 bits, made up of two 57 bit information bits, a 26 bit training sequence used for equalization, 1 stealing bit for each information block (used for FACCH), 3 tail bits at each end, and a 8.25-bit guard sequence. The 156.25 bits are transmitted in 0.577 msec, giving a gross bit rate of 270.833 kbps. All bursts having total length of 156.25 bits only differ in structure.

These are:

- normal burst
- frequency correction burst
- synchronization burst
- access burst
- dummy burst

The two models for each burst are: one for construction, one for disassembly.

## Measurements

Measurements include BER and FER.

## Modems

Implementation of modulation and demodulation of a GSM system is based on GSM 05.04 and GSM 05.05.

The modulation scheme recommended for GSM system is GMSK modulation with  $BT_b=0.3$  ( $B$  is the bandwidth for Gaussian filter,  $T_b$  is the bit duration time) and rate 270.833 kbits/s. GMSK is a type of constant-envelope FSK. The most important feature of GMSK is that it is a constant-envelope variety of modulation. This means there is a distinct lack of AM in the carrier with a consequent limiting of the occupied bandwidth. The constant amplitude of the GMSK signal makes it suitable for use with high efficiency amplifiers. The scheme is realized by GSM\_GMSKMod. It receives the bit stream and produces the modulated signal  $x_g(t)$ . In practice, instead of generating  $x_g(t)$  directly, we use complex envelope equivalent of  $x_g(t)$  and the carrier frequency  $f_c$  to represent it. This sub-network includes GSM\_DifferEncoder, GSM\_Rom and GSM\_Carrier.

In GSM systems, a burst has 156.25 bits. Since the 0.25-bit cannot be generated in framing models where the minimum unit is one bit, it is produced after modulation. This can be done because bits are sampled in GSM\_GMSKMod, and one bit has  $M$  samples, so 0.25-bit has  $0.25 \times M$  samples. After 156 bits in a burst are modulated, the  $0.25 \times M$  samples will be added to  $I(t)$  and  $Q(t)$ , the real and image parts of  $x_g(t)$ ; these  $0.25 \times M$  samples will be set to 0. This is done by model GSM\_AQuarterBitAdd. The quarter bit must be cut before synchronization.

[GMSK Modulation](#) is a block diagram of GMSK modulation.

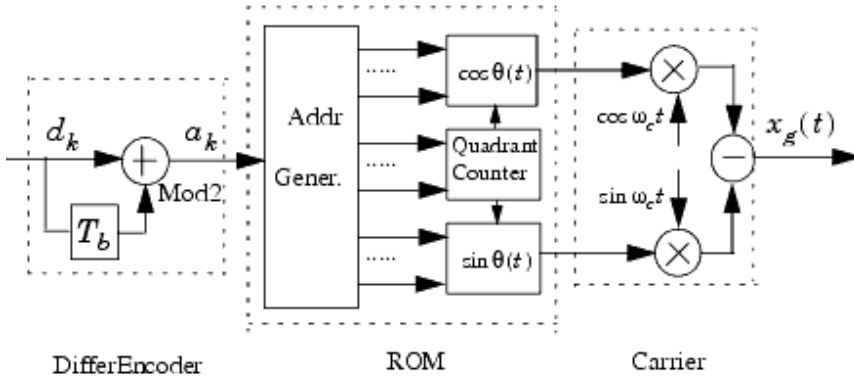

## GMSK Modulation

## Speech Coding

The basic models are provided as required by ETSI GSM 06.10, in which the specified transcoding procedure is applicable for the full-rate traffic channel (TCH) in GSM systems. Designers can build up the codec described in GSM specification or simulate their own speech codec algorithms used in telecommunication systems.

In GSM 06.10, the speech coding scheme called regular pulse excitation - long-term prediction - linear predictive coder (RPE-LTP) is specified. It describes the detailed mapping between input blocks of 160 speech samples in 13-bit uniform PCM format to encoded blocks of 260 bits and from encoded blocks of 260 bits to output blocks of 160 reconstructed speech samples. Basically, information from previous samples, which does not change quickly, is used to predict the current sample. Coefficients of the linear combination of the previous samples, plus an encoded form of the residual, the difference between the predicted and actual sample, represent the signal. Speech is divided into 20 msec samples, each of which is encoded as 260 bits, giving a total bit rate of 13 kbps.

In GSM 06.10, an implementation of the RPE-LTP algorithm in fixed-point arithmetic is provided using 16- and 32-bit integers. In GSM, the fixed-point class of Agilent's Advanced Design System is used.

This speech coding scheme can be divided into several small basic signal processing models as illustrated in [Block Diagram of GSM RPE-LTP Encoder](#) and [Block Diagram of GSM RPE-LTP Decoder](#).

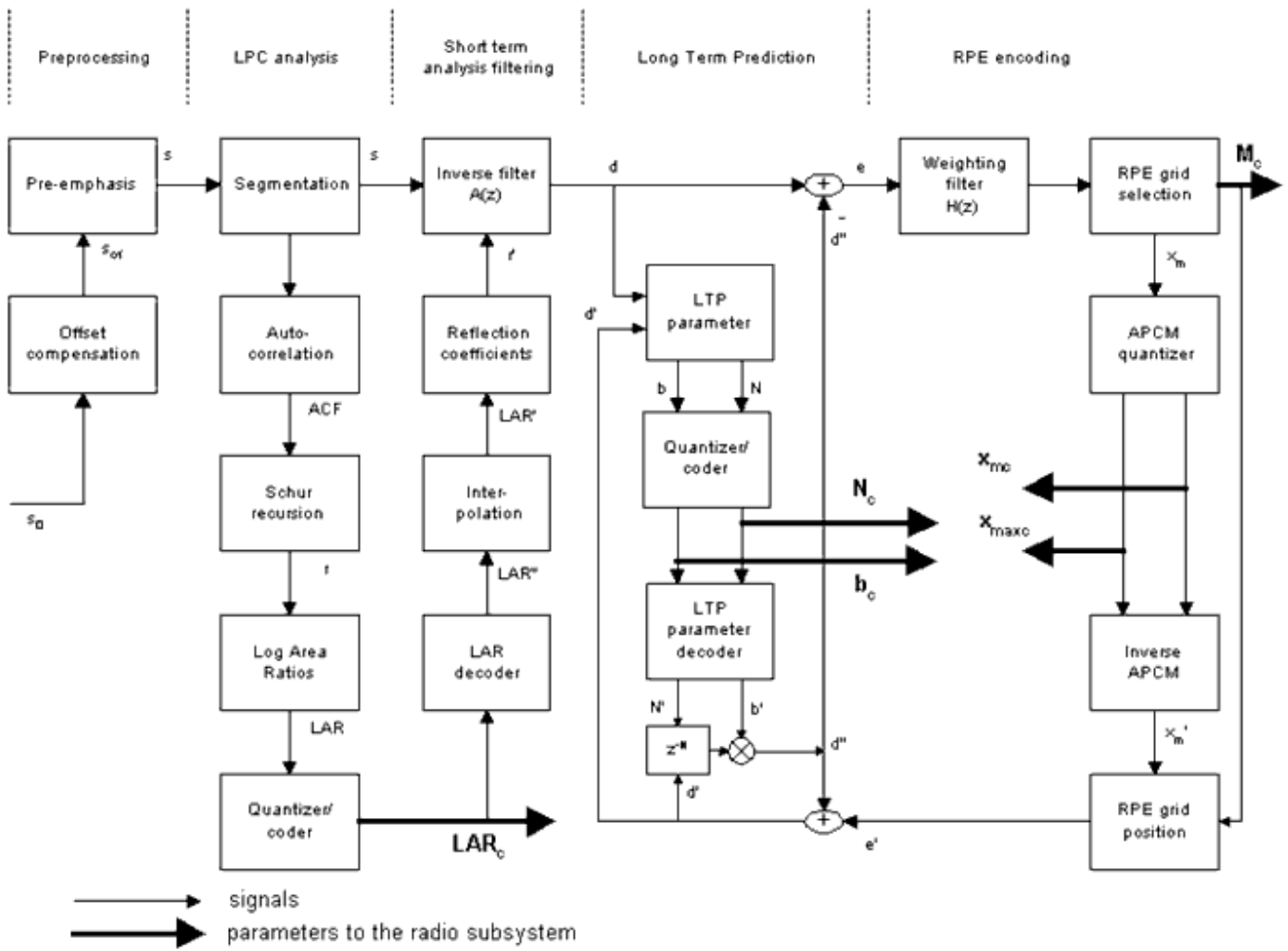

Block Diagram of GSM RPE-LTP Encoder

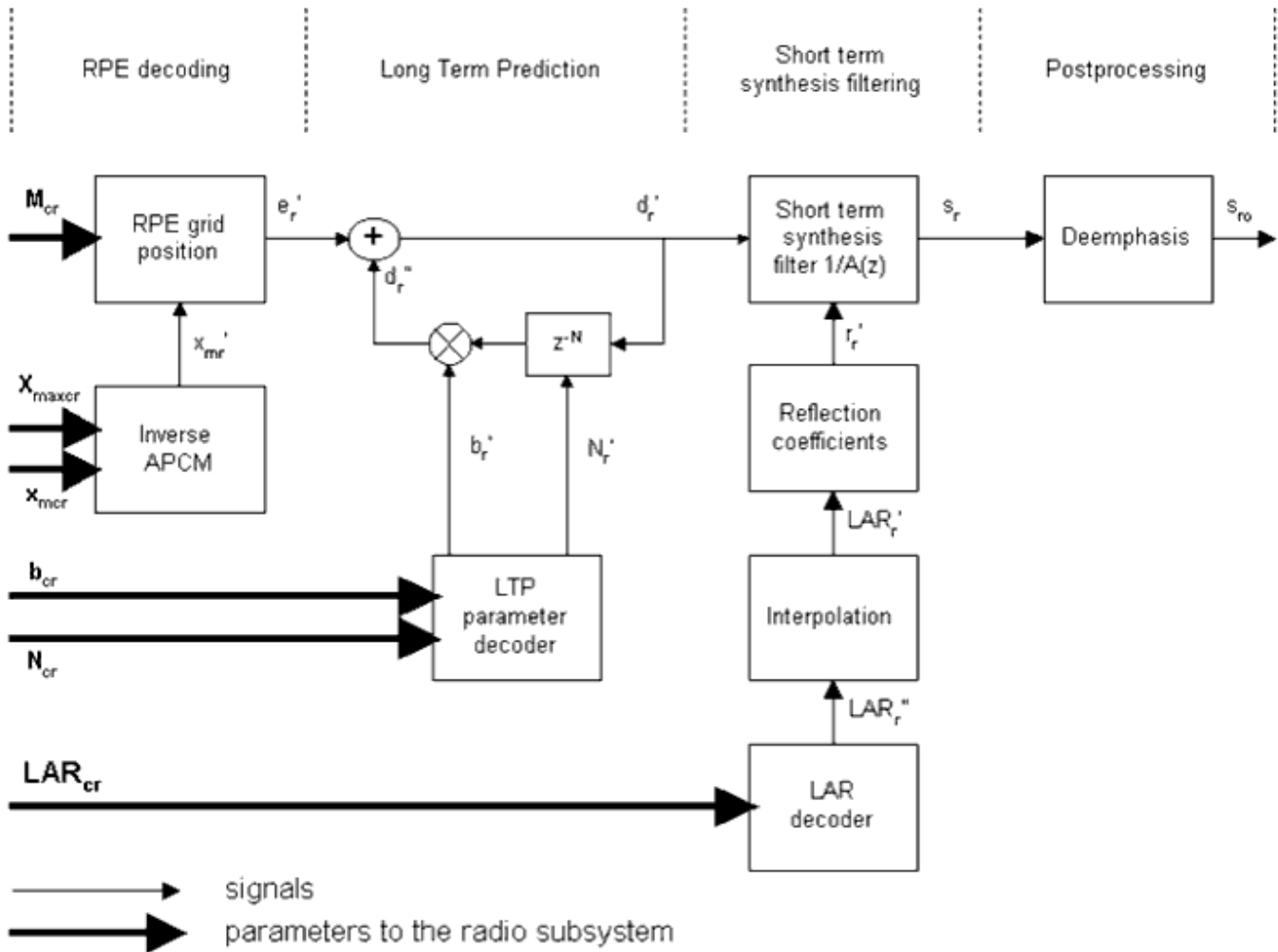

Block Diagram of GSM RPE-LTP Decoder

## Synchronization

Bit synchronization of the GSM receiver is carried out before equalization of the GSM receiver. In normal burst, eight training sequences have been defined with good cross-correlation properties in order to reduce the effects of interference among transmitters operating at the same frequency. All mobiles in a particular cell share the same training sequence, which is selected with the parameter TSC (training sequence code). Only the central 16 bits of the 26-bit training sequence are selected for correlation properties, because the first and last 5 bits are used for the time delay of the channel impulse response and the time-jitter of the received signal burst.

After symbol timing is implemented, one of the sample sequences made up of one sample per symbol will be determined, and the 0.25-bit from the 156.25 bits of one burst will be cut. The output of this part will be 156 bits with one sample per symbol.

Implementation of the GSM Bit Synchronization shows the implementation of GSM bit

synchronization. The reference training sequence  $\{P_k\}$  can be GMSK modulated before phase recovery.

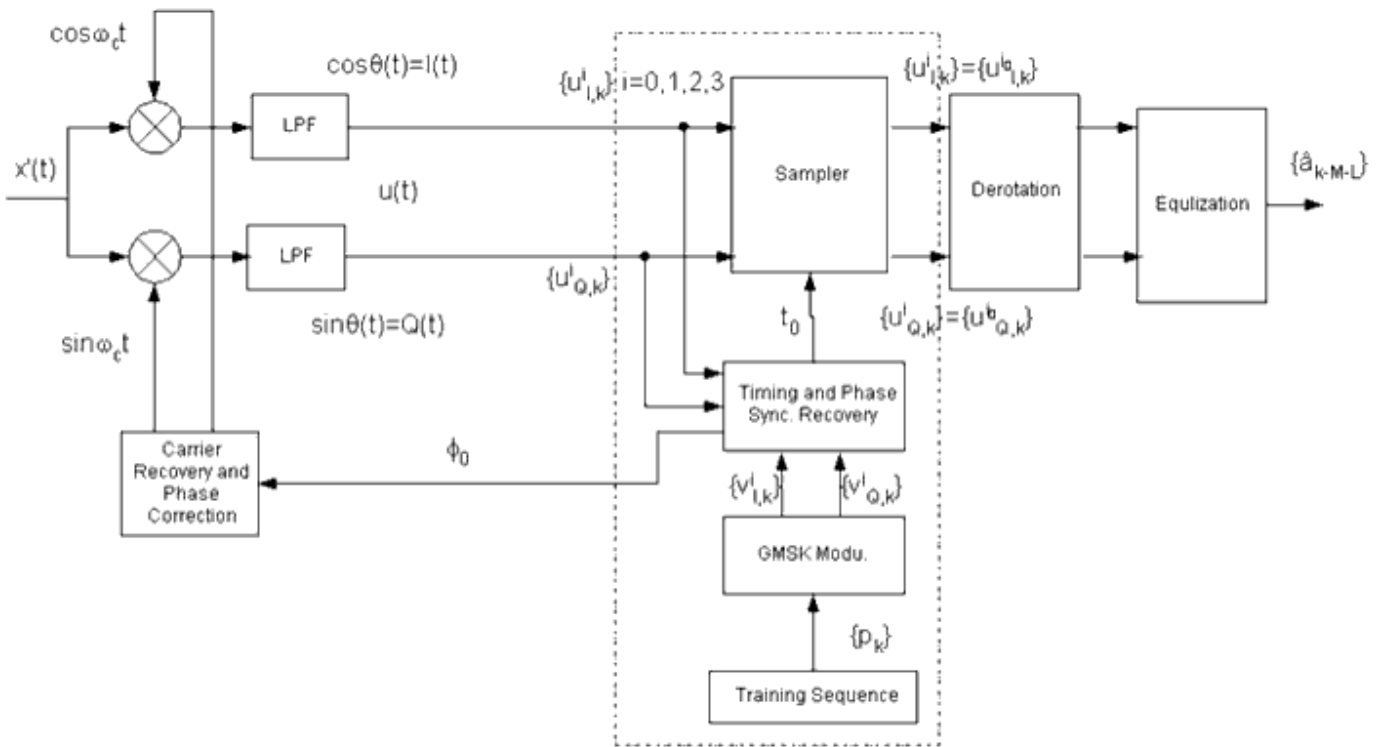

### Implementation of the GSM Bit Synchronization

## Glossary of Terms

ACPR	adjacent channel power ratio
AWGN	additive white Gaussian noise
BER	bit error rate
bps	bits per second
BSIC	base station identity code
CIR	channel impulse response
codec	coder and decoder
CRC	cyclic redundancy code
EVM	error vector magnitude
FACCH	fast associated control channel
FER	frame error rate
GMSK	gaussian minimum shift keying
GSM	global system for mobile communications
ISI	intersymbol interference
K	constraint length
LAR	log-area ratio
LPC	linear predictive coding
LSB	least significant bit
MLSE	maximum-likelihood sequence estimation
MS	mobile station
MSB	most significant bit
NRZ	non-return-to-zero
OQPSK	offset quadrature phase shift keying
PLMN	public land mobile network
QPSK	quadrature phase shift keying
RACH	random access channel
RPE-LTP	regular pulse excitation long term prediction
SACCH	slow associated control channel
SCH	synchronization channel
SDCCH	stand-alone dedicated control channel
SER	symbol error rate
SINR	signal-to-interference noise ratio
SIR	signal-to-interference ratio
TCH/FS	traffic channel/full-rate speech

## References

1. D. M. Redl, An Introduction to GSM, Artech House Publishers, Boston
2. European Telecommunications Standard Institute (ETSI), Rec. ETSI/GSM 03.03, Numbering, addressing and identification, version 3.5.1, March 1992.
3. European Telecommunications Standard Institute (ETSI), Rec. ETSI/GSM 04.06, Mobile Station - Base Station System (MS - BSS) interface Data Link (DL) layer specification, version 3.5.1, March 1992.
4. European Telecommunications Standard Institute (ETSI), Rec. ETSI/GSM 05.01, Physical Layer on the Radio Path General Descriptions, version 3.5.1, March 1992.
5. European Telecommunications Standard Institute (ETSI), Rec. ETSI/GSM 05.02, Multiplexing and Multiple Access on the Radio Path, version 3.5.1, March 1992.
6. European Telecommunications Standard Institute (ETSI), Rec. ETSI/GSM 05.03, Channel Coding, version 3.5.1, March 1992.
7. European Telecommunications Standard Institute (ETSI), Rec. ETSI/GSM 05.04, Modulation, version 3.5.1, March 1992.
8. European Telecommunications Standard Institute (ETSI), Rec. ETSI/GSM 05.05, Radio Transmission and Reception, version 3.5.1, March 1992.
9. European Telecommunications Standard Institute (ETSI), Rec. ETSI/GSM 05.10, Radio Subsystem Synchronization, version 3.5.1, March 1992.
10. European Telecommunications Standard Institute (ETSI), Rec. ETSI/GSM 06.01, Full Rate Speech Processing Functions, version 3.5.1, March 1992.
11. European Telecommunications Standard Institute (ETSI), Rec. ETSI/GSM 06.10, Full Rate Speech Transcoding, version 3.5.1, March 1992.
12. S. Lin, D. J. Costello, JR., ERROR CONTROL CODING Fundamentals and Applications, Prentice Hall, Englewood Cliffs, NJ, 1983
13. J. E. Meggit, Error Correcting Codes and Their Implementation, IRE Trans. Inf. Theory, IT-7, October 1961, pp. 232-244.
14. P. Q. Hua, L. W. Dong, H. Y. Hong, *GSM System GMSK Modulator* (in Chinese), Journal of Beijing University of Posts and Telecommunications, Vol.17, No.4, Dec., 1994, pp.20-25
15. P. Q. Hua, G. Yong, L. W. Dong, *Synchronization Design Theory Of Demodulation For Digital Land Mobile Radio System* (in Chinese), Journal of Beijing University of Posts and Telecommunications, Vol.18, No.2, Jun., 1995, pp.14-21
16. G. D'Aria, L. Stola, and V. Zingarelli, *Modeling and simulation of the propagation characteristics of the 900MHz narrowband-TDMA CEPT/GSM mobile radio*, in Proc. 39th IEEE Veh. Technol. Conf., San Francisco, CA, April 29-May 3, 1989, pp. 631-639
17. G. D'Aria, F. Muratore, *Simulation and Performance of the Pan-European Land Mobile Radio System*, IEEE Trans. on Vehicular Technology, Vol. 41, No.2, May 1992
18. G. Ungerboeck, *Adaptive maximum-likelihood receiver for carrier-modulated data-transmission system*, IEEE Trans. Commun., vol. COM-22, May 1974, pp. 624-636.
19. R. D'Avella, L. Moreno, M. Sant'Agostion, *An adaptive MLSE receiver for TDMA digital mobile radio*, IEEE Jour. on SAC, vol. 7, NO. 1, Jan 1989, pp. 122-129.

# Channel Coding Components for GSM Design Library

- *GSM BlockCodeRACH* (gsm)
- *GSM CC WithTail* (gsm)
- *GSM Combiner* (gsm)
- *GSM CycDecoder* (gsm)
- *GSM CycEncoder* (gsm)
- *GSM DCC WithTail* (gsm)
- *GSM Deinterleaver 4* (gsm)
- *GSM Deinterleaver 8* (gsm)
- *GSM Deinterleaver F96* (gsm)
- *GSM Depuncture* (gsm)
- *GSM FACCH Decoder* (gsm)
- *GSM FACCH Encoder* (gsm)
- *GSM FireDecoder* (gsm)
- *GSM Interleaver 4* (gsm)
- *GSM Interleaver 8* (gsm)
- *GSM Interleaver F96* (gsm)
- *GSM InverseReord* (gsm)
- *GSM Puncture* (gsm)
- *GSM RACH Decoder* (gsm)
- *GSM RACH Encoder* (gsm)
- *GSM Reorder* (gsm)
- *GSM RmvStlFlgs* (gsm)
- *GSM SACCH Decoder* (gsm)
- *GSM SACCH Encoder* (gsm)
- *GSM SCH Decoder* (gsm)
- *GSM SCH Encoder* (gsm)
- *GSM Splitter* (gsm)
- *GSM TailBits* (gsm)
- *GSM TCHF24 Decoder* (gsm)
- *GSM TCHF24 Encoder* (gsm)
- *GSM TCHF48 Decoder* (gsm)
- *GSM TCHF48 Encoder* (gsm)
- *GSM TCHF96 Decoder* (gsm)
- *GSM TCHF96 Encoder* (gsm)
- *GSM TCHFS Decoder* (gsm)
- *GSM TCHFS Encoder* (gsm)



# GSM\_BlockCodeRACH



**Description:** Random Access Channel Block Encoding or Decoding

**Library:** GSM, Channel Coding

**Class:** SDFGSM\_BlockCodeRACH

## Pin Inputs

Pin	Name	Description	Signal Type
1	input	input data, 8 information bits and 6 parity ( or color ) bits	int
2	BSIC	6 BSIC bits	int

## Pin Outputs

Pin	Name	Description	Signal Type
3	output	output data, 8 information bits and 6 colour bits ( or parity bits )	int

## Notes/Equations

1. This model is used with GSM random access channel. In channel coding, its bitwise modulo-2 adds the 6 base station identity codes (BSIC) to the 6 parity bits; this results in 6 color bits. In channel decoding, BSIC bits are added on the color bits to restore the parity bits.  
14 output tokens are produced for each 14 input tokens consumed at the input pin; 6 tokens are consumed at the BSIC pin.

## References

1. European Telecommunications Standard Institute (ETSI), Rec. ETSI/GSM 05.03, Channel Coding, version 5.1.0, May 1996.
2. European Telecommunications Standard Institute (ETSI), Rec. ETSI/GSM 03.03, Numbering, addressing and identification, version 5.0.0, March 1996.

# GSM\_CC\_WithTail



**Description:** Convolutional Encoder with Tail

**Library:** GSM, Channel Coding

**Class:** SDFGSM\_CC\_WithTail

## Parameters

Name	Description	Default	Unit	Type	Range
CCType	convolutional code type: rate 1/2 K 9 g0 0753 g1 0561, rate 1/3 K 9 g0 0557 g1 0663 g2 0711, rate 1/2 K 7 g0 0554 g1 0744, rate 1/3 K 7 g0 0554 g1 0624 g2 0764, rate 1/2 K 5 g0 046 g1 072, rate 1/3 K 5 g0 066 g1 052 g2 076, rate 1/2 K 5 g0 046 g1 066, rate 1/6 K 5 g0 066 g1 052 g2 076 g3 066 g4 052 g5 076, rate 1/2 K 3 g0 05 g1 07	rate 1/2 K 9 g0 0753 g1 0561		enum	†
InputFrameLen	length of input frame	96		int	[K, ∞)

† If  $6 < K < 9$ , only higher  $K$  bits of generator are used, the lower  $(9-K)$  bits are zeros. The generator is written in octal format  $0xxx$ . For rate 1/2 K 7 g0 0554 g1 0744,  $K=7$ . The generator  $g1$  is  $D^6 + D^5 + D^4 + D^3 + 1$ , it is written as 111100100 (that is 0744).

If  $3 < K < 6$ , the generator is written as  $0xx$ , it contain 6 bits, the lower  $(6-K)$  bits are zeros and not used.

where  $K$  is the constraint length of convolutional coding, the octal digit following  $g_i$  ( $i=0,1, \dots$ ) represents the generation polynomial.

## Pin Inputs

Pin	Name	Description	Signal Type
1	input	data to be convolutionally encoded	int

## Pin Outputs

Pin	Name	Description	Signal Type
2	output	convolutionally encoded symbols	int

## Notes/Equations

1. This model is used to convolutionally encode the input tailed frame. InputFrameLen/rate (specified in CCType) output tokens are produced when InputFrameLen input tokens are consumed.

## References

1. S. Lin and D. J. Costello, Jr., *Error Control Coding Fundamentals and Applications*, Prentice Hall, Englewood Cliffs NJ, 1983.

# GSM\_Combiner



**Description:** Combine Two Inputs into One Output

**Library:** GSM, Channel Coding

**Class:** SDFGSM\_Combiner

## Parameters

Name	Description	Default	Unit	Type	Range
N1	block length of first input	182		int	(0, $\infty$ )
N2	block length of second input	78		int	(0, $\infty$ )

## Pin Inputs

Pin	Name	Description	Signal Type
1	in1	first of two inputs	real
2	in2	second of two inputs	real

## Pin Outputs

Pin	Name	Description	Signal Type
3	out	output data	real

## Notes/Equations

1. This model is used to combine the two input blocks into one output block, used in TCH/FS to combine class 1 bits and class 2 bits, or class 1a bits (the first 50 bits of class 1) and class 1b bits (the bits of class 1 other than class 1a bits in the speech frame).  $N1+N2$  output tokens are produced for each  $N1$  input tokens consumed at pin in1 and  $N2$  input tokens consumed at pin in2.
2. The output is  $N1$  signals of in1 followed by  $N2$  signals of in2.

## References

1. European Telecommunications Standard Institute (ETSI), Rec. ETSI/GSM 05.03, *Channel Coding*, version 5.1.0, May 1996.

# GSM\_CycDecoder



**Description:** Systematic Cyclic Codes Decoder

**Library:** GSM, Channel Coding

**Class:** SDFGSM\_CycDecoder

## Parameters

Name	Description	Default	Symbol	Unit	Type	Range
ShortenFlag	shortened code flag: Not Shortened Code, Shortened Code	Shortened Code			enum	†
CorrectFlag	error correction flag: Detection Only, Detection and Correction	Detection Only			enum	
N	length of code word	53	n		int	(0, ∞) ††
K	length of information part in code word	50	k		int	(0:N) N-K=order of g(D)
GenType	type of generator polynomial: Using Enum Type selector GenEnum, Using Array Type selector GenArr	Using Enum Type selector GenEnum			enum	
GenEnum	used to select g(D) generator polynomial (valid when GenType = 0): g 13, g 157, g 2565	g 13			enum	
GenArr	used to specify g(D) generator polynomial, in octal form, MSB first (valid when GenType = 1)	1 3			int array	[0:7] for every element †††
SS	number of bits shortened in a code word (if this is a shortened cyclic code)	0	ss		int	(0, ∞) †

† ShortenFlag is not used when CorrectFlag=Detection Only;

SS is only used when CorrectFlag=Detection and Correction and ShortenFlag=Shortened Code

†† The range of N should also satisfy:

$(D^N + 1)$  should be divisible by  $g(D)$  when ShortenFlag=Not Shortened Code and CorrectFlag=Detection and Correction, or

$(D^{(N+SS)} + 1)$  should be divisible by  $g(D)$  when ShortenFlag=Shortened Code and CorrectFlag=Detection and Correction, where  $g(D)$  is the generator polynomial specified by GenEnum or GenArr.

††† The last element of the array must be an odd number.

## Pin Inputs

Pin	Name	Description	Signal Type
1	input	received code word	int

**Pin Outputs**

Pin	Name	Description	Signal Type
2	output	decoded information block	int
3	errMsg	message indicating whether there is a error which cannot be corrected	int

**Notes/Equations**

1. This model is used to decode cyclically encoded data.  
K output tokens are produced for each N input token consumed, where N is the length of the code word and K is the length of the information in the code word.

2. Implementation

The Meggit decoder [1][2] is used. [Cyclic Codes Decoder](#) shows the cyclic codes decoder with received polynomial  $r(D)$  is shifted into the syndrome register.

$$r(D) = r_0D^{n-1} + r_1D^{n-2} + \dots + r_{n-2}D + r_{n-1}$$

is the polynomial of received code word  $g_i, i = 0, 1, \dots, n - k$ , are the coefficients of generator polynomial  $g(D)$ ,

$$g(D) = g_0D^{n-k} + g_1D^{n-k-1} + \dots + g_{n-k-1}D + g_{n-k}$$

The decoder is designed to correct one error (at most) in a code word.

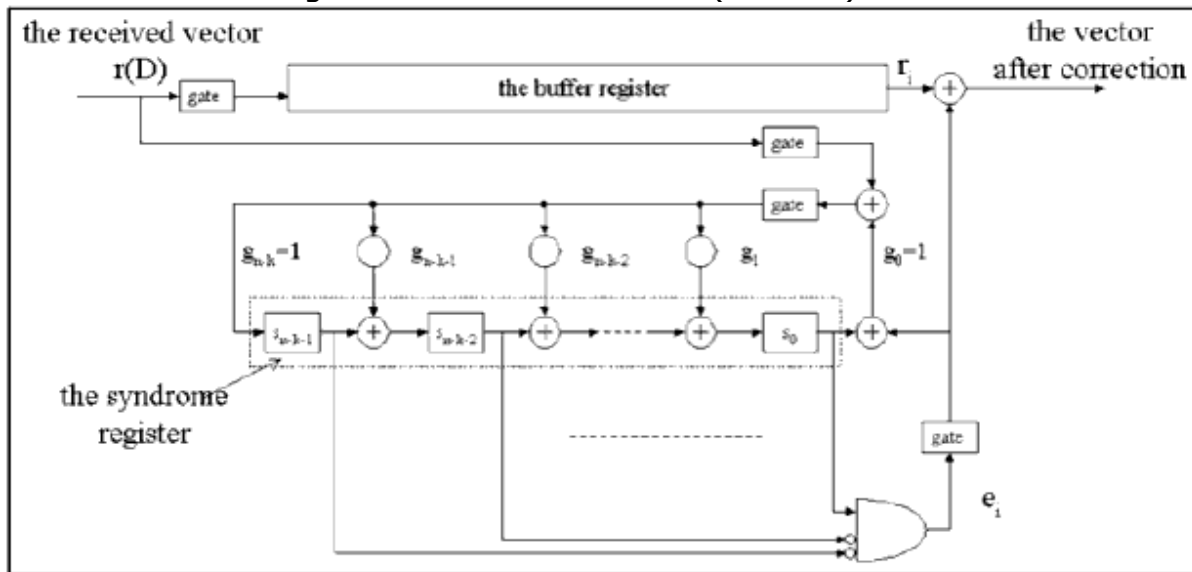

**Cyclic Codes Decoder**

**References**

1. J. E. Meggit, Error Correcting Codes and Their Implementation, IRE Trans. Inf. Theory, IT-7, October 1961, pp. 232-244.

2. S. Lin and D. J. Costello, Jr., *Error Control Coding Fundamentals and Applications*, Prentice Hall, Englewood Cliffs NJ, 1983.

# GSM\_CycEncoder



**Description:** Systematic Cyclic Codes Encoder

**Library:** GSM, Channel Coding

**Class:** SDFGSM\_CycEncoder

## Parameters

Name	Description	Default	Symbol	Unit	Type	Range
N	length of code word	53	n		int	$(0, \infty) \dagger$
K	length of information part in code word	50	k		int	$(0:N)$ $N-K = \text{order of } g(D)$
GenType	type of generator polynomial selector: Using Enum Type selector GenEnum, Using Array Type selector GenArr	Using Enum Type selector GenEnum			enum	
GenEnum	$g(D)$ generator polynomial (valid when GenType = 0): g 13, g 157, g 2565, g 45045, g 123, g 20000440400011	g 13			enum	
GenArr	$g(D)$ generator polynomial, in octal form, MSB first (valid when GenType = 1)	1 3			int array	$[0:7]$ for every element $\dagger\dagger$

$\dagger$   $(D^N + 1)$  must be divisible by  $g(D)$  where  $g(D)$  is the generator polynomial specified by GenEnum or GenArr.

$\dagger\dagger$  The last element in the array must be an odd number.

## Pin Inputs

Pin	Name	Description	Signal Type
1	input	information block to be encoded	int

## Pin Outputs

Pin	Name	Description	Signal Type
2	output	code word in systematic form	int

## Notes/Equations

1. This model is used to encode input data into cyclic codes. N output tokens are produced for each K tokens consumed.
2. Implementation



The systematic cyclic codes encoding circuit (a dividing circuit) is shown in [Systematic Cyclic Codes Encoding Circuit](#). The gate is opened while the information bits are shifted into the circuit. After all data is read, the  $n-k$  bits in the registers become the parity-check bits. And the gate closes, the switch changes to the lower position to shift out the parity bits.

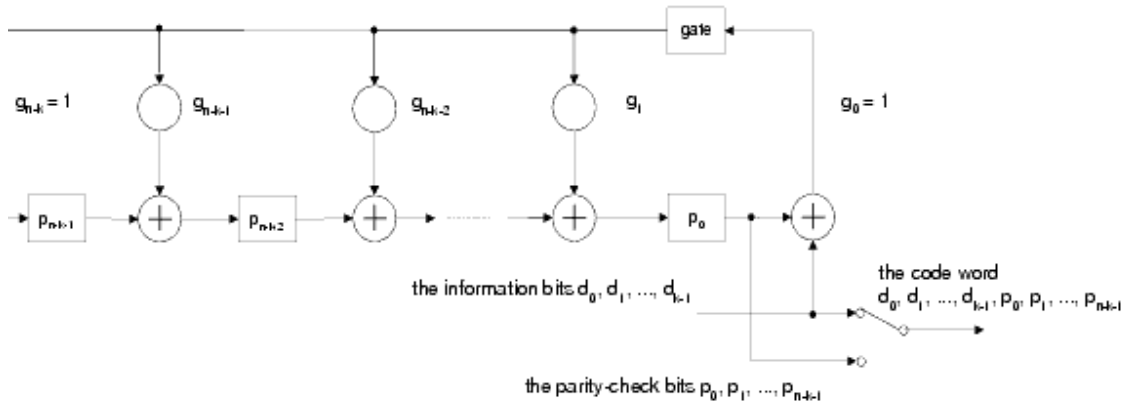

### Systematic Cyclic Codes Encoding Circuit

The cyclic codes used in GSM channels are:

TCH/FS:  $n = 53, k = 50, g(D) = D^3 + D + 1$

RACH:  $n = 14, k = 8, g(D) = D^6 + D^5 + D^3 + D^2 + D + 1$

SCH:  $n = 35, k = 25, g(D) = D^{10} + D^8 + D^6 + D^5 + D^4 + D^2 + 1$

SACCH, BCCH, PCH, AGCH, CBCH, SDCCH, FACCH:  $n = 224, k = 184,$

$g(D) = (D^{17} + D^3 + 1)(D^{23} + 1) = D^{40} + D^{26} + D^{23} + D^{17} + D^3 + 1$  (Fire code).

To agree with GSM05.03 (when divided by  $g(D)$ ), the code word yields a remainder equal to  $1 + D + D^2 + \dots + D^{(N-K-1)}$ . The parity-check bits is reversed before added at the end of information bits.

### References

1. S. Lin and D. J. Costello, Jr., *Error Control Coding Fundamentals and Applications*, Prentice Hall, Englewood Cliffs NJ, 1983.
2. European Telecommunications Standard Institute (ETSI), Rec. ETSI/GSM 05.03, *Channel Coding*, version 5.1.0, May 1996.

# GSM\_DCC\_WithTail



**Description:** Viterbi Decoder for Convolutional Code with Tail

**Library:** GSM, Channel Coding

**Class:** SDFGSM\_DCC\_WithTail

## Parameters

Name	Description	Default	Unit	Type	Range
CCType	convolutional code type: rate 1/2 K 9 g0 0753 g1 0561, rate 1/3 K 9 g0 0557 g1 0663 g2 0711, rate 1/2 K 7 g0 0554 g1 0744, rate 1/3 K 7 g0 0554 g1 0624 g2 0764, rate 1/2 K 5 g0 046 g1 072, rate 1/3 K 5 g0 066 g1 052 g2 076, rate 1/2 K 5 g0 046 g1 066, rate 1/6 K 5 g0 066 g1 052 g2 076 g3 066 g4 052 g5 076, rate 1/2 K 3 g0 05 g1 07	rate 1/2 K 9 g0 0753 g1 0561		enum	†
InputFrameLen	input frame length	288		int	[K+1, ∞)

† If  $6 < K < 9$ , only higher K generator bits are used, the lower (9-K) bits are all zeros. The generator is written in octal format 0xxx. For rate 1/2 K 7 g0 0554 g1 0744, K=7.

Generator g1 is  $D6+D5+D4+D3+1$ , written as 111100100 (that is, 0744).

If  $3 < K < 6$ , the generator is written as 0xx; it contain 6 bits, the lower(6-K)bits are zeros and is not used.

where K is the constraint length of convolutional coding and  $g_i$  ( $i=0,1, \dots$ ) followed by an octal digit represents the generation polynomial.

## Pin Inputs

Pin	Name	Description	Signal Type
1	input	the symbols to be decoded.	real

## Pin Outputs

Pin	Name	Description	Signal Type
2	output	the decoded bits.	int

## Notes/Equations

1. This model is used to viterbi-decode convolutional code with tail. InputFrameLen × rate (specified by CCType) output tokens are produced when InputFrameLen input tokens are consumed.

## References

1. S. Lin and D. J. Costello, Jr., *Error Control Coding Fundamentals and Applications*, Prentice Hall, Englewood Cliffs NJ, 1983.
2. R. Steele, *Mobile Radio Communication*, London: Pentech Press, 1992.

## GSM\_Deinterleaver\_4



**Description:** Block Rectangular De-interleaver

**Library:** GSM, Channel Coding

**Class:** SDFGSM\_Deinterleaver\_4

### Pin Inputs

Pin	Name	Description	Signal Type
1	input	input data, four 114-bit interleaved sub-blocks	real

### Pin Outputs

Pin	Name	Description	Signal Type
2	output	output data, one 456-bit block	real

### Notes/Equations

1. This model is used to de-interleave data that is block rectangular interleaved in GSM channels SACCH, BCCH, PCH, AGCH, SDCCH and CBCH. 456 output tokens are produced for each 456 input tokens consumed.

### References

1. European Telecommunications Standard Institute (ETSI), Rec. ETSI/GSM 05.03, *Channel Coding*, version 5.1.0, May 1996

## GSM\_Deinterleaver\_8



**Description:** Block Diagonal De-interleaver

**Library:** GSM, Channel Coding

**Class:** SDFGSM\_Deinterleaver\_8

### Pin Inputs

Pin	Name	Description	Signal Type
1	input	input data, four 114-bit interleaved sub-blocks	real

### Pin Outputs

Pin	Name	Description	Signal Type
2	output	output data, one 456-bit block	real

### Notes/Equations

1. This model is used to de-interleave data that is block diagonally interleaved in GSM channels TCH/FS, TCH/F2.4 and FACCH. 456 output tokens are produced for each 456 input tokens consumed.

### References

1. European Telecommunications Standard Institute (ETSI), Rec. ETSI/GSM 05.03, *Channel Coding*, version 5.1.0, May 1996.

## GSM\_Deinterleaver\_F96



**Description:** Diagonal De-interleaver

**Library:** GSM, Channel Coding

**Class:** SDFGSM\_Deinterleaver\_F96

### Pin Inputs

Pin	Name	Description	Signal Type
1	input	input data, 114-bit interleaved block	real

### Pin Outputs

Pin	Name	Description	Signal Type
2	output	output data, 114-bit data block	real

### Notes/Equations

1. This model is used to de-interleave data that is diagonally interleaved in GSM channels TCH/F9.6, TCH/F4.8, TCH/H4.8, and TCH/H2.4. 114 output tokens are produced for each 114 input consumed.

### References

1. European Telecommunications Standard Institute (ETSI), Rec. ETSI/GSM 05.03, *Channel Coding*, version 5.1.0, May 1996.

# GSM\_Depuncture



**Description:** Data Depuncture

**Library:** GSM, Channel Coding

**Class:** SDFGSM\_Depuncture

## Pin Inputs

Pin	Name	Description	Signal Type
1	input	punctured convolutionally encoded symbols	real

## Pin Outputs

Pin	Name	Description	Signal Type
2	output	depunctured convolutionally encoded symbols	real

## Notes/Equations

1. This model is used to insert zeros in the input symbols for implementing Viterbi decoding for punctured convolutional code in GSM data channel. 488 output tokens are produced when 456 input tokens consumed.

## References

1. European Telecommunications Standard Institute (ETSI), Rec. ETSI/GSM 05.03, *Channel Coding*, version 5.1.0, May 1996

# GSM\_FACCH\_Decoder



**Description:** Fast Associated Control Channel Decoder

**Library:** GSM, Channel Coding

**Class:** SDFGSM\_FACCH\_Decoder

## Pin Inputs

Pin	Name	Description	Signal Type
1	input	received data frames	real

## Pin Outputs

Pin	Name	Description	Signal Type
2	output1	recovered controlling data frames	int
3	output2	error message from the Fire codes decoder	int

## Notes/Equations

1. This subnetwork is used to decode fast associated control channel (FACCH) data.
2. Implementation

The structure of this subnetwork is shown in [GSM\\_FACCH\\_Decoder Subnetwork](#). It consists of a stealing flag cutter, a de-interleaver, a convolutional codes decoder, a tail bits cutter and a Fire codes decoder.

Two stealing flag bits are cut from every 116-bit block; the four remaining 114-bit blocks are combined and de-interleaved. The 456 bits are convolutionally decoded by a rate 1/2, constraint length 5 decoder, and four tail bits are cut from the resulting 228 decoded bits. The 224-bit code word is decoded by the Fire code decoder and 184 output bits are produced.

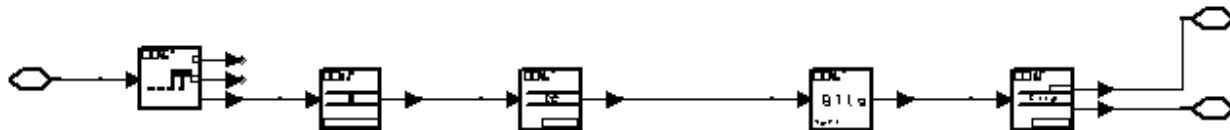

[GSM\\_FACCH\\_Decoder Subnetwork](#)

## References



1. European Telecommunications Standard Institute (ETSI), Rec. ETSI/GSM 05.03, *Channel Coding*, version 5.1.0, May 1996.

# GSM\_FACCH\_Encoder



**Description:** Fast Associated Control Channel Encoder

**Library:** GSM, Channel Coding

**Class:** SDFGSM\_FACCH\_Encoder

## Pin Inputs

Pin	Name	Description	Signal Type
1	input	controlling data frames of FACCH	int

## Pin Outputs

Pin	Name	Description	Signal Type
2	output	channel encoded data sequences	int

## Notes/Equations

1. This subnetwork is used to encode fast associated control channel (FACCH) data.
2. Implementation

The structure of this subnetwork is shown in [GSM\\_FACCH\\_Encoder Subnetwork](#). It includes a cyclic codes encoder (implementing Fire codes encoding), a tail bits inserter, a convolutional codes encoder and an interleaver. Each 184-bit input block is cyclically encoded to form a 224-bit code word and four tail bits are inserted to the end of the code word. The 228-bit data block is encoded by a rate 1/2, constraint length 5 convolutional codes encoder. The output 456-bit code word is block diagonal interleaved and two stealing flags are inserted.

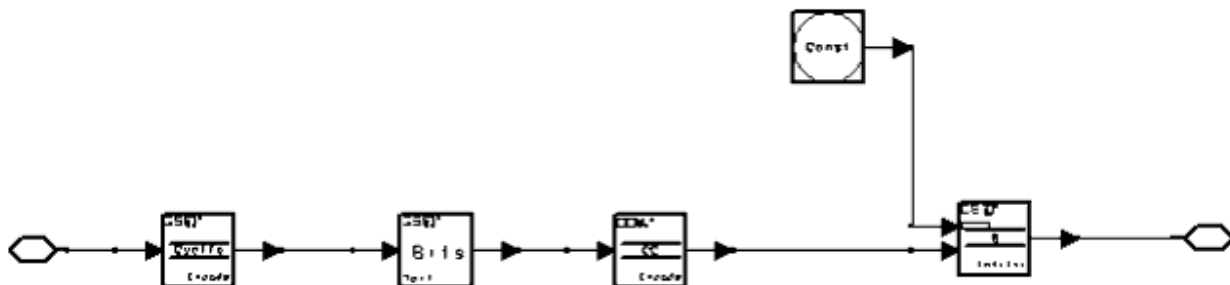

## GSM\_FACCH\_Encoder Subnetwork

## References

1. European Telecommunications Standard Institute (ETSI), Rec. ETSI/GSM 05.03, *Channel Coding*, version 3.5.1, March 1992.

# GSM\_FireDecoder



**Description:** Fire Code Decoder

**Library:** GSM, Channel Coding

**Class:** SDFGSM\_FireDecoder

## Parameters

Name	Description	Default	Symbol	Unit	Type	Range
ShortenFlag	flag to indicate shortened code: Not Shortened Code, Shortened Code	Not Shortened Code			enum	
GSM_CCH_Flag	flag to indicate control channel code: General Fire Codes Decoder, Fire Codes Decoder for GSM CCH	Fire Codes Decoder for GSM CCH			enum	†
N	length of code word	279	n		int	(0, ∞) ††
K	length of information part in code word	265	k		int	(0:N) N-(2L-1)-K = order of g1(D)
Gen1	select g1(D), one of two generator polynomials of Fire code, in octal form: g1 45, g1 13, g1 400011	g1 45			enum	
L	one of the parameters of a Fire code, and the other generator polynomial is g2(D) = D^(2*L-1) + 1	5	l		int	(0:(N-K+1)/2) +++
SS	number of bits shortened in a code word (used only when ShortenFlag=Shortened Code)	0	ss		int	(0, ∞)

† If GSM\_CCH\_Flag=Fire Codes Decoder for GSM CCH, all other parameters will not be used.

†† N must also satisfy:

$(D^N+1)$  must be divisible by  $g(D)$  when ShortenFlag=Not Shortened Code, or

$(D^{(N+SS)}+1)$  must be divisible by  $g(D)$  when ShortenFlag=Shortened Code,

where  $g(D)$  is the generator polynomial generated by  $g1(D)$  and  $g2(D)$ , and  $g1(D)$  is specified by Gen1,  $g2(D) = D^{(2L-1)}+1$ .

+++ N+SS (when ShortenFlag=Shortened Code) or

N (when ShortenFlag=Not Shortened Code)

must equal  $\text{LCM}(2L-1, \text{period})$ , where period is the generator polynomial  $g1(D)$  period.

## Pin Inputs

Pin	Name	Description	Signal Type
1	input	received code word	int

### Pin Outputs

Pin	Name	Description	Signal Type
2	output	decoded information block	int
3	errMsg	the message indicating error that cannot be corrected	int

### Notes/Equations

1. This model is used to decode Fire coded data.  
K output tokens are produced for each N input token consumed.

### References

1. European Telecommunications Standard Institute (ETSI), Rec. ETSI/GSM 05.03, *Channel Coding*, version 5.1.0, May 1996.
2. S. Lin and D. J. Costello, Jr., *Error Control Coding Fundamentals and Applications*, Prentice Hall, Englewood Cliffs NJ, 1983.

## GSM\_Interleaver\_4



**Description:** Block Rectangular Interleaver

**Library:** GSM, Channel Coding

**Class:** SDFGSM\_Interleaver\_4

### Parameters

Name	Description	Default	Unit	Type	Range
CheckBit	check input bits option: Check and stop at error, Check and warn the error, No Checking	Check and stop at error		enum	

### Pin Inputs

Pin	Name	Description	Signal Type
1	input	input data, one 456-bit block	int
2	chType	channel type, should be 1 here	int

### Pin Outputs

Pin	Name	Description	Signal Type
3	output	interleaved data and stealing flags, four 116-bit sub-blocks	int

### Notes/Equations

1. This model is used to interleave the input data in a block rectangular manner. 464 output tokens are produced for each 456 input tokens consumed at pin input and one token is consumed at pin chType.

2. Implementation

The interleaving rule is:

$$i(B, j) = c(n, k) \quad k = 0, 1, \dots, 455$$

$$n = 0, 1, \dots, N, N + 1, \dots$$

$$B = B_0 + 4n + (k \bmod 4)$$

$$j = 2((49k) \bmod 57) + (k \bmod 8) \operatorname{div} 4$$

where  $c(n, k)$  is the  $k$ th bit in the  $n$ th 456-bit coded data block,  $N$  marks a certain data block,  $i(B, j)$  is the  $j$ th bit in the  $B$ th 114-bit interleaved sub-block, and  $B_0$  is the

initial value of  $B$ . The block of coded data is block rectangular interleaved, that is, a new data block starts every 4th block and is distributed over 4 blocks. Two stealing flags  $hu(B)$  and  $hl(B)$  are inserted into each block after interleaving. The flags should be equal to 1 here to indicate control channels. In coding implementation, a preset table is used in converting the index  $k$  to the index  $j$ .

## References

1. European Telecommunications Standard Institute (ETSI), Rec. ETSI/GSM 05.03, *Channel Coding*, version 5.1.0, May 1996.

## GSM\_Interleaver\_8



**Description:** Block Diagonal Interleaver

**Library:** GSM, Channel Coding

**Class:** SDFGSM\_Interleaver\_8

### Parameters

Name	Description	Default	Unit	Type	Range
CheckBit	check input bits option: Check and stop at error, Check and warn the error, No Checking	Check and stop at error		enum	

### Pin Inputs

Pin	Name	Description	Signal Type
1	input	input data, one 456-bit block	int
2	chType	channel type, 0 for TCH/FS, TCH/F2.4 and 1 for FACCH	int

### Pin Outputs

Pin	Name	Description	Signal Type
3	output	interleaved data and stealing flags, four 116-bit sub-blocks	int

### Notes/Equations

1. This model is used to interleave input data in a block diagonal manner. 464 output tokens are produced for each 456 input tokens consumed at pin input and one token is consumed at pin chType.

2. Implementation

The interleaving rule is:

$$i(B, j) = c(n, k) \quad k = 0, 1, \dots, 455$$

$$n = 0, 1, \dots, N, N + 1, \dots$$

$$B = B_0 + 4n + (k \bmod 8)$$

$$j = 2((49k) \bmod 57) + (k \bmod 8) \operatorname{div} 4$$

where  $c(n, k)$  is the  $k$ th bit in the  $n$ th 456-bit coded data block,  $N$  marks a certain data block,  $i(B, j)$  is the  $j$ th bit in the  $B$ th 114-bit interleaved sub-block, and  $B_0$  is the initial value of  $B$ . Stealing flags  $hu(B)$  and  $hl(B)$  are inserted into each block after interleaving; the flags are 0 for TCH/FS or TCH/F2.4 and 1 for FACCH. In coding implementation, a preset table is used to convert index  $k$  to index  $j$ .



## References

1. European Telecommunications Standard Institute (ETSI), Rec. ETSI/GSM 05.03, *Channel Coding*, version 5.1.0, May 1996.

# GSM\_Interleaver\_F96



**Description:** Diagonal Interleaver

**Library:** GSM, Channel Coding

**Class:** SDFGSM\_Interleaver\_F96

## Parameters

Name	Description	Default	Unit	Type	Range
CheckBit	check input bits option: Check and stop at error, Check and warn the error, No Checking	Check and stop at error		enum	

## Pin Inputs

Pin	Name	Description	Signal Type
1	input	input data, 114-bit data block	int
2	chType	channel type (must be 0 here to indicate data traffic channel)	int

## Pin Outputs

Pin	Name	Description	Signal Type
3	output	interleaved data block and two stealing flags, 116-bit block	int

## Notes/Equations

1. This model is used to interleave the input data in a diagonal manner. 116 output tokens are produced for each 114 input tokens consumed at pin input and one token consumed at pin chType.

2. Implementation

The interleaving rule is:

$$\begin{aligned}
 i(B, j) &= c(n, k) & k &= 0, 1, \dots, 455 \\
 & & n &= 0, 1, \dots, N, N+1, \dots \\
 & & B &= B_0 + 4n + (k \bmod 19) + (k \operatorname{div} 114) \\
 & & j &= k \bmod 19 + 19(k \bmod 6)
 \end{aligned}$$

where  $c(n, k)$  is the  $k$ th bit in the  $n$ th 456-bit coded data block,  $N$  marks a certain data block,  $i(B, j)$  is the  $j$ th bit in the  $B$ th 114-bit interleaved sub-block, and  $B_0$  is the initial value of  $B$ . By dividing the 456-bit data block into four 114-bit blocks, we can

$$\begin{aligned}
 i(B, j) &= c(n', k) & k &= 0, 1, \dots, 113 \\
 & & n' &= 0, 1, \dots, N, N + 1, \dots \\
 & & B &= B_0 + n' + (k \bmod 19) \\
 & & j &= k \bmod 19 + 19(k \bmod 6)
 \end{aligned}$$

change the rule to

where  $n' = 4n + (k \text{ div } 114)$

is the index of the new blocks. Stealing flags  $hu(B)$  and  $hl(B)$  are inserted into each block after interleaving. The flags must be 0 to indicate traffic channels. In coding implementation, a preset table is used in converting index  $k$  to index  $j$ . The interleaver output will have a  $114 \times 19$  token delay.

## References

1. European Telecommunications Standard Institute (ETSI), Rec. ETSI/GSM 05.03, *Channel Coding*, version 5.1.0, May 1996.

# GSM\_InverseReord



**Description:** TCH/FS Inverse Reorder

**Library:** GSM, Channel Coding

**Class:** SDFGSM\_InverseReord

## Parameters

Name	Description	Default	Unit	Type	Range
CheckBit	check input bits option: Check and stop at error, Check and warn the error, No Checking	Check and stop at error		enum	

## Pin Inputs

Pin	Name	Description	Signal Type
1	input	reordered data	int

## Pin Outputs

Pin	Name	Description	Signal Type
2	cls1a	class 1a bits and 3 parity bits	int
3	cls1b	class 1b bits	int

## Notes/Equations

- This model is used to invert the reordering on the information and parity bits of TCH/FS frames.  
53 output tokens at cls1a and 132 output tokens at cls1b are produced for each 185 input tokens consumed.
- Implementation  
The inverse reordering rule is:  

$$d(2k) = u(k) \text{ and } d(2k + 1) = u(184 - k) \text{ for } k = 0, 1, \dots, 90$$

$$p(k) = u(91 + k) \text{ for } k = 0, 1, 2$$
 where  $d(k)$ ,  $k = 0, 1, \dots, 181$  are the bits of class 1,  $p(k)$ ,  $k = 0, 1, 2$  are the parity bits of the class 1a bits, and  $u(k)$ ,  $k = 0, 1, \dots, 184$  are the reordered bits.

## References

- European Telecommunications Standard Institute (ETSI), Rec. ETSI/GSM 05.03, *Channel Coding*, version 5.1.0, May 1996.

# GSM\_Puncture



**Description:** Data Puncture

**Library:** GSM, Channel Coding

**Class:** SDFGSM\_Puncture

## Pin Inputs

Pin	Name	Description	Signal Type
1	input	convolutionally encoded symbols.	int

## Pin Outputs

Pin	Name	Description	Signal Type
2	output	punctured Convolutionally encoded symbols.	int

## Notes/Equations

1. This model is used to puncture the input stream to implement punctured convolutional code for GSM data channel. 456 output tokens are produced when 488 input tokens consumed.

## References

1. European Telecommunications Standard Institute (ETSI), Rec. ETSI/GSM 05.03, *Channel Coding*, version 5.1.0, May 1996.

# GSM\_RACH\_Decoder



**Description:** Random Access Channel Decoder

**Library:** GSM, Channel Coding

**Class:** SDFGSM\_RACH\_Decoder

## Pin Inputs

Pin	Name	Description	Signal Type
1	input1	received data frames	real
2	input2	base station identity codes	int

## Pin Outputs

Pin	Name	Description	Signal Type
3	output1	recovered controlling data frames	int
4	output2	error message from the Fire codes decoder	int

## Notes/Equations

1. This subnetwork is used to decode random access channel data.
2. Implementation

The structure of this subnetwork is shown in [GSM\\_RACH\\_Decoder Subnetwork](#). It consists of a convolutional codes decoder, a tail bits cutter, base station identity codes (BSIC) adder, and a cyclic codes decoder. The input 36-bit block is convolutionally decoded by a rate 1/2, constraint length 5 decoder, and four tail bits are cut from the resulting 18 bits. In the remaining 14 bits, there are six color bits that are masked with the 6 BSIC bits to produce six parity check bits. These parity check bits and the other eight information bits are cyclically decoded and eight output bits are produced.

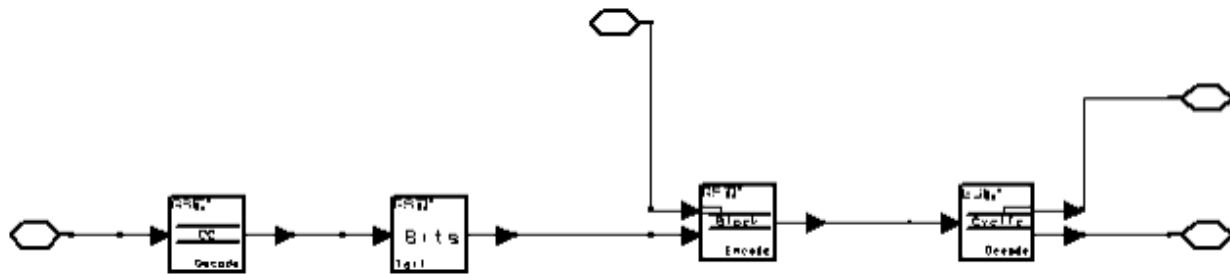

## GSM\_RACH\_Decoder Subnetwork

## References

1. European Telecommunications Standard Institute (ETSI), Rec. ETSI/GSM 05.03, *Channel Coding*, version 3.5.1, March 1992.

# GSM\_RACH\_Encoder



**Description:** Random Access Channel Encoder

**Library:** GSM, Channel Coding

**Class:** SDFGSM\_RACH\_Encoder

## Pin Inputs

Pin	Name	Description	Signal Type
1	input1	controlling random access channel data frames	int
2	input2	base station identity codes	int

## Pin Outputs

Pin	Name	Description	Signal Type
3	output	channel encoded data sequences	int

## Notes/Equations

1. This subnetwork is used to encode random access channel data.
2. Implementation

The structure of this subnetwork is shown in [GSM\\_RACH\\_Encoder Subnetwork](#). It consists of a cyclic codes encoder, a BSIC (Base Station Identity Codes) adder, a tail bits inserter, and a convolutional codes encoder. Every 8-bit input block is cyclically encoded to form a 14-bit code word, and the six parity check bits in it are masked with 6 BSIC bits, result in 6 color bits. Then four tail bits are inserted to the end of the code word. Finally the 18-bit block is encoded by a rate 1/2, constraint length 5 convolutional codes encoder, and produce 36 output bits.

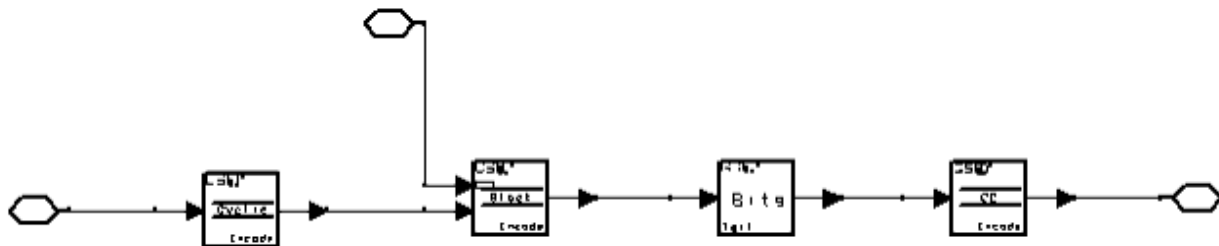

## GSM\_RACH\_Encoder Subnetwork



## References

1. European Telecommunications Standard Institute (ETSI), Rec. ETSI/GSM 05.03, *Channel Coding*, version 3.5.1, March 1992.

# GSM\_Reorder



**Description:** TCH/FS Reorder

**Library:** GSM, Channel Coding

**Class:** SDFGSM\_Reorder

## Parameters

Name	Description	Default	Unit	Type	Range
CheckBit	check input bits option: Check and stop at error, Check and warn the error, No Checking	Check and stop at error		enum	

## Pin Inputs

Pin	Name	Description	Signal Type
1	cls1a	cyclic encoded class 1a bits and 3 parity bits	int
2	cls1b	class 1b bits	int

## Pin Outputs

Pin	Name	Description	Signal Type
3	out	reordered data	int

## Notes/Equations

- This model is used to reorder the information and parity bits of TCH/FS frames. 185 output tokens are produced, 53 input tokens are consumed at the cls1a pin and 132 input tokens are consumed at the cls1b pin.
- Implementation  
The reordering rule is:  

$$u(k) = d(2k) \text{ and } u(184 - k) = d(2k + 1) \text{ for } k = 0, 1, \dots, 90$$

$$u(91 + k) = p(k) \text{ for } k = 0, 1, 2$$
 where  $d(k)$ ,  $k=0, 1, \dots, 181$  are the bits of class 1,  $p(k)$ ,  $k=0, 1, 2$  are the parity bits of the class 1a bits, and  $u(k)$ ,  $k=0, 1, \dots, 184$  are the reordered bits.

## References

- European Telecommunications Standard Institute (ETSI), Rec. ETSI/GSM 05.03, *Channel Coding*, version 5.1.0, May 1996.

# GSM\_RmvStlFlgs



**Description:** Remove Stealing Flags

**Library:** GSM, Channel Coding

**Class:** SDFGSM\_RmvStlFlgs

## Pin Inputs

Pin	Name	Description	Signal Type
1	input	116-bit data block of normal burst	real

## Pin Outputs

Pin	Name	Description	Signal Type
2	output	114-bit information block without stealing flags	real
3	hl	stealing flag $hl(B) = e(B,57)$ : odd-numbered bits in the 114-bit block	real
4	hu	stealing flag $hu(B) = e(B,58)$ : even numbered bits in the 114-bit block	real

## Notes/Equations

- This model removes the two stealing flags from the burst before de-interleaving. 144 output, 1 hl and 1 hu tokens are produced for each 116 input tokens consumed.
- Implementation  
Upper layer models will select an appropriate de-interleaving scheme using the stealing flags. The stealing flags are  $hl(B)$  and  $hu(B)$ , where  $B$  is the index of the data block. Assume  $d(B, k)$ ,  $B = 0, 1, \dots$ ,  $k = 0, 1, \dots, 115$ , are the bits in block  $B$ , then  $hl(B) = d(B, 57)$  and  $hu(B) = d(B, 58)$ .

## References

- European Telecommunications Standard Institute (ETSI), Rec. ETSI/GSM 05.03, *Channel Coding*, version 5.1.0, May 1996.

# GSM\_SACCH\_Decoder



**Description:** Slow Associated Control Channel Decoder

**Library:** GSM, Channel Coding

**Class:** SDFGSM\_SACCH\_Decoder

## Pin Inputs

Pin	Name	Description	Signal Type
1	input	received data frames	real

## Pin Outputs

Pin	Name	Description	Signal Type
2	output1	recovered controlling data frames	int
3	output2	error message from the Fire codes decoder	int

## Notes/Equations

1. This subnetwork is used to decode slow associated control channel data.
2. Implementation

The structure of this subnetwork is shown in [GSM\\_SACCH\\_Decoder Subnetwork](#). It consists of a stealing flag cutter, a de-interleaver, a convolutional codes decoder, a tail bits cutter and a Fire codes decoder.

Two stealing flag bits are cut from every 116-bit block. Four remaining 114-bit blocks are combined together and de-interleaved. Then the 456 bits are convolutionally decoded by a rate 1/2, constraint length 5 decoder, and four tail bits are cut from the resulting 228 decoded bits. Finally the 224-bit codeword is decoded by the Fire code decoder and 184 output bits are produced.

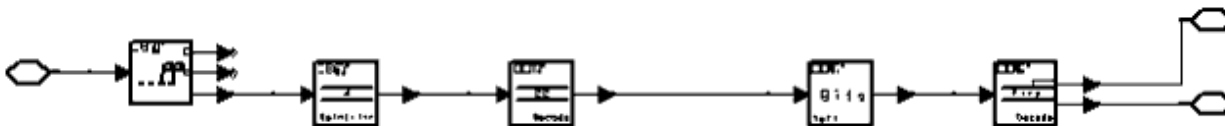

## GSM\_SACCH\_Decoder Subnetwork

## References

1. European Telecommunications Standard Institute (ETSI), Rec. ETSI/GSM 05.03, *Channel Coding*, version 3.5.1, March 1992.

# GSM\_SACCH\_Encoder



**Description:** Slow Associated Control Channel Encoder

**Library:** GSM, Channel Coding

**Class:** SDFGSM\_SACCH\_Encoder

## Pin Inputs

Pin	Name	Description	Signal Type
1	input	controlling data frames of slow associated control channel	int

## Pin Outputs

Pin	Name	Description	Signal Type
2	output	channel encoded data sequences	int

## Notes/Equations

1. This subnetwork is used to encode slow associated control channel data.
2. Implementation  
 The structure of this subnetwork is shown in [GSM\\_SACCH\\_Encoder Subnetwork](#). It consists of a cyclic codes encoder (implementing Fire codes encoding), a tail bits inserter, a convolutional codes encoder and an interleaver. Every 184-bit input block is cyclically encoded to form a 224-bit codeword and four tail bits are inserted to the end of the codeword. Then the 228-bit data block is encoded by a rate 1/2, constraint length 5 convolutional codes encoder, and the output 456-bit codeword is divided into four 114-bit sub-blocks. Finally the interleaver interleaves these sub-blocks in a "block rectangular" way and inserts two stealing flags in them.

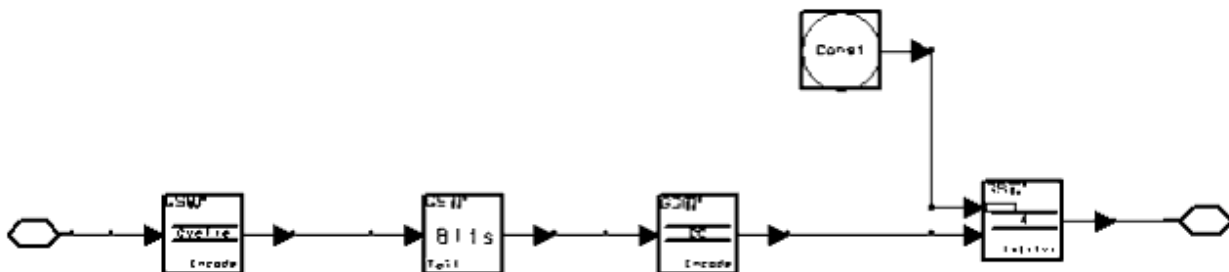

## GSM\_SACCH\_Encoder Subnetwork

## References

1. European Telecommunications Standard Institute (ETSI), Rec. ETSI/GSM 05.03, *Channel Coding*, version 3.5.1, March 1992.

# GSM\_SCH\_Decoder



**Description:** Synchronization Channel Decoder

**Library:** GSM, Channel Coding

**Class:** SDFGSM\_SCH\_Decoder

## Pin Inputs

Pin	Name	Description	Signal Type
1	input	received data frames	real

## Pin Outputs

Pin	Name	Description	Signal Type
2	output1	recovered controlling data frames	int
3	output2	error message from cyclic codes decoder	int

## Notes/Equations

1. This subnetwork is used to decode synchronization channel data.
2. Implementation

The structure of this subnetwork is shown in [GSM\\_SCH\\_Decoder Subnetwork](#). It consists of a convolutional codes decoder, a tail bits cutter and a cyclic codes decoder. A 78-bit input block is convolutionally decoded by the rate 1/2, constraint length 5 decoder, and four tail bits are cut from the resulting 39 decoded bits. The 35-bit codeword is further decoded by the cyclic codes decoder and 25 output bits are produced.



## GSM\_SCH\_Decoder Subnetwork

## References

1. European Telecommunications Standard Institute (ETSI), Rec. ETSI/GSM 05.03, *Channel Coding*, version 5.1.0, May 1996.



# GSM\_SCH\_Encoder



**Description:** Synchronization Channel Encoder

**Library:** GSM, Channel Coding

**Class:** SDFGSM\_SCH\_Encoder

## Pin Inputs

Pin	Name	Description	Signal Type
1	input	controlling data frames of SCH	int

## Pin Outputs

Pin	Name	Description	Signal Type
2	output	channel encoded data sequences	int

## Notes/Equations

1. This subnetwork is used to encode synchronization channel (SCH) data.
2. Implementation  
The structure of this subnetwork is shown in [GSM\\_SCH\\_Encoder Subnetwork](#). It consists of a cyclic codes encoder, a tail bits inserter and a convolutional codes encoder. Each 25-bit input block is cyclically encoded to form a 35-bit codeword and four tail bits are inserted to the end of the codeword. The 39-bit data block is encoded by a rate 1/2, constraint length 5 convolutional codes encoder and 78 output bits are produced.



## GSM\_SCH\_Encoder Subnetwork

## References

1. European Telecommunications Standard Institute (ETSI), Rec. ETSI/GSM 05.03, *Channel Coding*, version 5.1.0, May 1996.

# GSM\_Splitter

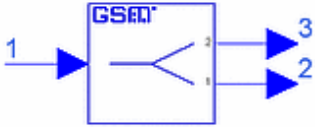

**Description:** Split Input Block into Two Output Blocks

**Library:** GSM, Channel Coding

**Class:** SDFGSM\_Splitter

## Parameters

Name	Description	Default	Unit	Type	Range
N1	block length of first output	182		int	(0, ∞)
N2	block length of second output	78		int	(0, ∞)

## Pin Inputs

Pin	Name	Description	Signal Type
1	in	input data	real

## Pin Outputs

Pin	Name	Description	Signal Type
2	out1	first of two outputs	real
3	out2	second of two outputs	real

## Notes/Equations

1. This model is used to split the input block into two output blocks. It is used in TCH/FS to separate class 1 and class 2 bits, or class 1a bits (the first 50 bits of class 1) and class 1b bits (the bits of class 1 other than class 1a bits in the speech frame). Each firing, N1 output tokens at out1 and N2 tokens at out2 are produced for each N1+N2 input tokens consumed.

## References

1. European Telecommunications Standard Institute (ETSI), Rec. ETSI/GSM 05.03, *Channel Coding*, version 5.1.0, May 1996.

# GSM\_TailBits



**Description:** Add or Remove Tailing Bits

**Library:** GSM, Channel Coding

**Class:** SDFGSM\_TailBits

## Parameters

Name	Description	Default	Unit	Type	Range
AddRmvSwitch	tailing bits option: Adding, Removing	Adding		enum	
CheckBit	check input bits option: Check and stop at error, Check and warn the error, No Checking	Check and stop at error		enum	
N	number of tailing bits in a frame	4		int	(0, ∞)
InfoLen	number of information bits in a frame	185		int	(0, ∞)

## Pin Inputs

Pin	Name	Description	Signal Type
1	input	input frame	int

## Pin Outputs

Pin	Name	Description	Signal Type
2	output	output frame	int

## Notes/Equations

- This model is used to add tailing bits to or remove tailing bits from the input frames.  $N + \text{InfoLen}$  output tokens are produced for each  $\text{InfoLen}$  input token consumed when  $\text{AddRmvSwitch} = \text{Adding}$ ;  $\text{InfoLen}$  output tokens are produced for each  $N + \text{InfoLen}$  input token consumed when  $\text{AddRmvSwitch} = \text{Removing}$ .
- Implementation  
When  $\text{AddRmvSwitch} = \text{Adding}$ ,  $N$  tailing bits are added after each  $\text{InfoLen}$  information bits; when  $\text{AddRmvSwitch} = \text{Removing}$ ,  $N$  tailing bits are removed from each  $N + \text{InfoLen}$  input bits.

## References

- European Telecommunications Standard Institute (ETSI), Rec. ETSI/GSM 05.03, *Channel Coding*, version 5.1.0, May 1996.

# GSM\_TCHF24\_Decoder



**Description:** TCH/F2.4 Channel Decoder

**Library:** GSM, Channel Coding

**Class:** SDFGSM\_TCHF24\_Decoder

## Pin Inputs

Pin	Name	Description	Signal Type
1	input	received data frames	real

## Pin Outputs

Pin	Name	Description	Signal Type
2	output	recovered data frames	int

## Notes/Equations

1. This subnetwork is used to decode full rate traffic channel (2.4kbit/s) (TCH/F2.4) data.

2. Implementation

This subnetwork is shown in [GSM\\_TCHF24\\_Decoder Subnetwork](#). It consists of a stealing flag cutter, a de-interleaver, a convolutional codes decoder and a tail bits cutter. Two stealing flag bits are cut from every 116-bit block. Four remaining 114-bit blocks are combined and de-interleaved. The 456 bits are convolutionally decoded by a rate 1/6, constraint length 5 decoder. Four tail bits are cut from the resulting 76 decoded bits.

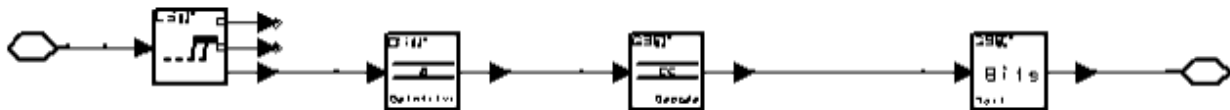

[GSM\\_TCHF24\\_Decoder Subnetwork](#)

## References

1. European Telecommunications Standard Institute (ETSI), Rec. ETSI/GSM 05.03, *Channel Coding*, version 5.1.0, May 1996.

# GSM\_TCHF24\_Encoder



**Description:** TCH/F2.4 Channel Encoder

**Library:** GSM, Channel Coding

**Class:** SDFGSM\_TCHF24\_Encoder

## Pin Inputs

Pin	Name	Description	Signal Type
1	input	data frames of TCH/F2.4	int

## Pin Outputs

Pin	Name	Description	Signal Type
2	output	channel encoded data sequences	int

## Notes/Equations

1. This subnetwork is used to encode full rate traffic channel (2.4 kbit/s) (TCH/F2.4) data.
2. Implementation  
This subnetwork is shown in [GSM\\_TCHF24\\_Encoder Subnetwork](#). It consists of a tail bits inserter, a convolutional codes encoder, and an interleaver. Four tail bits are inserted into each 72 input information bits. These 76 bits are convolutionally coded in rate 1/6, constraint length 5 encoder and interleaved in a block diagonal manner.

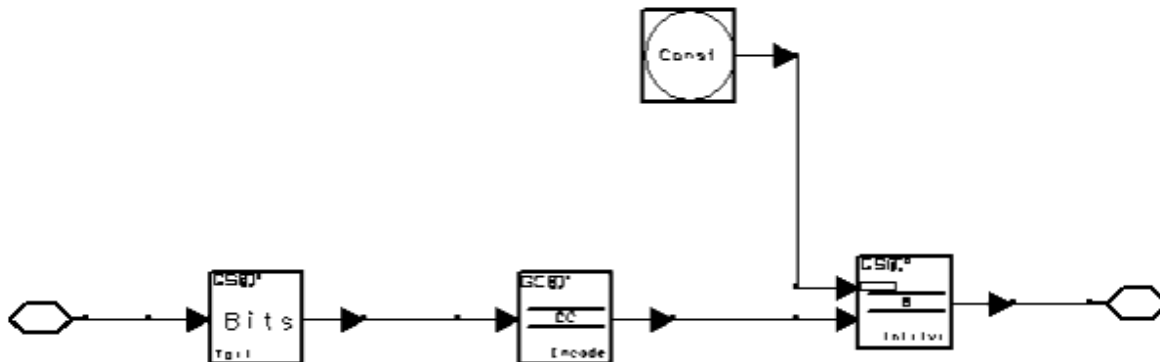

[GSM\\_TCHF24\\_Encoder Subnetwork](#)

## References

1. European Telecommunications Standard Institute (ETSI), Rec. ETSI/GSM 05.03, *Channel Coding*, version 5.1.0, May 1996.

# GSM\_TCHF48\_Decoder



**Description:** TCH/F4.8 Channel Decoder

**Library:** GSM, Channel Coding

**Class:** SDFGSM\_TCHF48\_Decoder

## Pin Inputs

Pin	Name	Description	Signal Type
1	input	received data frames	real

## Pin Outputs

Pin	Name	Description	Signal Type
2	output	recovered data frames	int

## Notes/Equations

1. This subnetwork is used to decode full rate traffic channel (4.8kbit/s) (TCH/F4.8) data.

2. Implementation

The subnetwork structure is shown in [GSM\\_TCHF48\\_Decoder Subnetwork](#). It consists of a stealing flag cutter, a de-interleaver, a convolutional codes decoder, and a tail bits cutter. Two stealing flag bits are cut from each 116-bit block; the remaining 114-bit block is de-interleaved in a diagonal manner. A delay of 228 bits is inserted to keep the bit index consistent. Four 114-bit de-interleaved blocks are combined and convolutionally decoded by a rate 1/3, constraint length 5 decoder. Four tail bits are cut from each 19 bits.

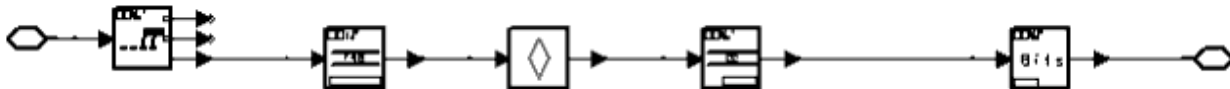

[GSM\\_TCHF48\\_Decoder Subnetwork](#)

## References

1. European Telecommunications Standard Institute (ETSI), Rec. ETSI/GSM 05.03, *Channel Coding*, version 5.1.0, May 1996.

# GSM\_TCHF48\_Encoder



**Description:** TCH/F4.8 Channel Encoder

**Library:** GSM, Channel Coding

**Class:** SDFGSM\_TCHF48\_Encoder

## Pin Inputs

Pin	Name	Description	Signal Type
1	input	data frames of TCH/F4.8	int

## Pin Outputs

Pin	Name	Description	Signal Type
2	output	channel encoded data sequences	int

## Notes/Equations

1. This subnetwork is used to encode full rate traffic channel (4.8 kbits) (TCH/F4.8) data.
2. Implementation

This subnetwork is shown in [GSM\\_TCHF48\\_Encoder Subnetwork](#). It consists of a tail bits inserter, a convolutional codes encoder and an interleaver. Four tail bits are inserted into each 15 input information bits.  $8(15+4)=152$  bits are convolutionally encoded by a rate 1/3, constraint length 5 encoder, and interleaved in a diagonal manner.

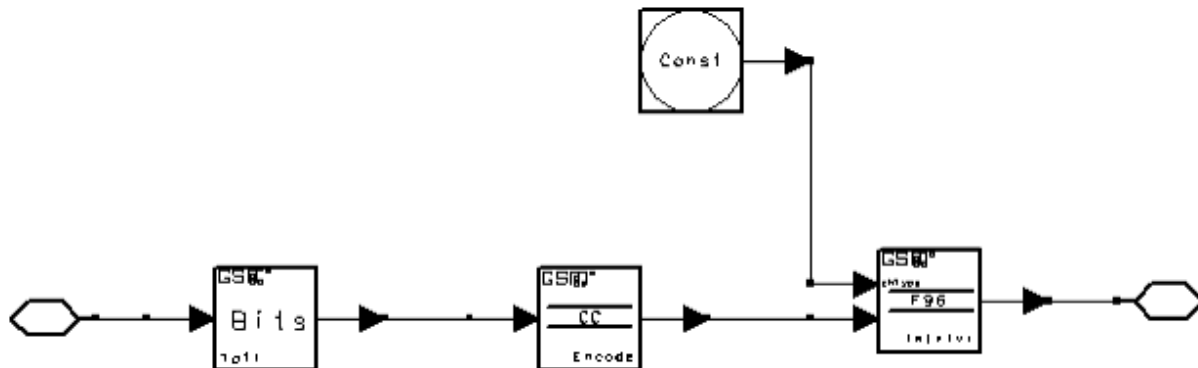

[GSM\\_TCHF48\\_Encoder Subnetwork](#)



## References

1. European Telecommunications Standard Institute (ETSI), Rec. ETSI/GSM 05.03, *Channel Coding*, version 5.1.0, May 1996.

# GSM\_TCHF96\_Decoder



**Description:** TCH/F9.6 Channel Decoder

**Library:** GSM, Channel Coding

**Class:** SDFGSM\_TCHF96\_Decoder

## Pin Inputs

Pin	Name	Description	Signal Type
1	input	received data frames	real

## Pin Outputs

Pin	Name	Description	Signal Type
2	output	recovered data frames	int

## Notes/Equations

1. This subnetwork is used to decode full rate traffic channel (9.6 kbits) (TCH/F9.6) data.
2. Implementation

This subnetwork structure is shown in [GSM\\_TCHF96\\_Decoder Subnetwork](#). It consists of a stealing flag cutter, a de-interleaver, a delayer, a de-puncturer, a convolutional codes decoder, and a tail bits cutter. Two stealing flag bits are cut from each 116-bit block; the remaining 114-bit block is de-interleaved in a diagonal manner. A delay of 228 bits is inserted to keep the bit index consistent. Four 114-bit de-interleaved blocks are combined, de-punctured and convolutionally decoded by a rate 1/2, constraint length 5 decoder. Four tail bits are cut from every 244 bits.



## GSM\_TCHF96\_Decoder Subnetwork

## References

1. European Telecommunications Standard Institute (ETSI), Rec. ETSI/GSM 05.03, *Channel Coding*, version 5.1.0, May 1996.

# GSM\_TCHF96\_Encoder



**Description:** TCH/F9.6 Channel Encoder

**Library:** GSM, Channel Coding

**Class:** SDFGSM\_TCHF96\_Encoder

## Pin Inputs

Pin	Name	Description	Signal Type
1	input	data frames of TCH/F9.6	int

## Pin Outputs

Pin	Name	Description	Signal Type
2	output	channel encoded data sequences	int

## Notes/Equations

1. This subnetwork is used to encode full rate traffic channel (9.6kbit/s) (TCH/F9.6) data.
2. Implementation

This subnetwork structure is shown in [GSM\\_TCHF96\\_Encoder Subnetwork](#). It consists of a tail bits inserter, a convolutional codes encoder, a puncturer, and an interleaver. Four tail bits are inserted into each 240 input information bits; these 244 bits are convolutionally encoded in rate 1/2, constraint length of 5 encoder, uniformly punctured, and interleaved in a diagonal manner.

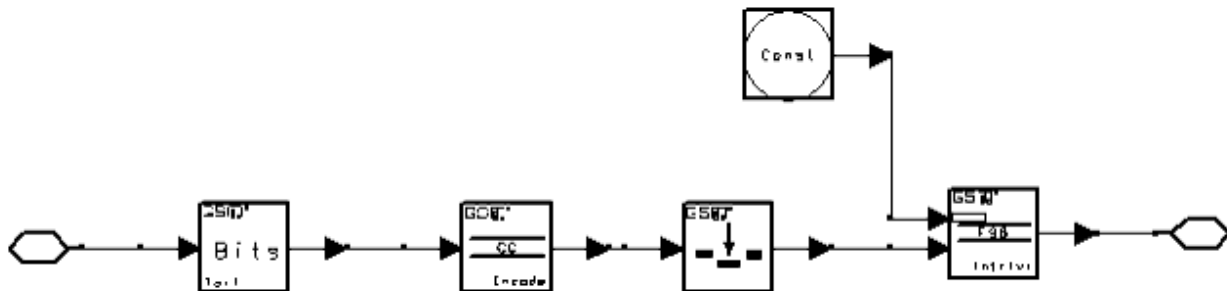

**GSM\_TCHF96\_Encoder Subnetwork**

## References

1. European Telecommunications Standard Institute (ETSI), Rec. ETSI/GSM 05.03, *Channel Coding*, version 5.1.0, May 1996.

# GSM\_TCHFS\_Decoder



**Description:** TCH/FS Channel Decoder

**Library:** GSM, Channel Coding

**Class:** SDFGSM\_TCHFS\_Decoder

## Pin Inputs

Pin	Name	Description	Signal Type
1	input	received data frames	real

## Pin Outputs

Pin	Name	Description	Signal Type
2	output1	output	int
3	output2	error message from the cyclic codes decoder	int

## Notes/Equations

1. This subnetwork is used to decode full rate traffic channel (TCH/FS) data.
2. Implementation

This subnetwork is shown in [GSM\\_TCHFS\\_Decoder Subnetwork](#). It includes a stealing flag cutter, a de-interleaver, a splitter, a convolutional codes decoder, a tail bits cutter, an inverse reorderer, a cyclic codes decoder and two combiners.

[TCH/FS Codec Data Flow](#) shows the data flow of this subnetwork (refer to GSM\_TCHFS\_Encoder also).

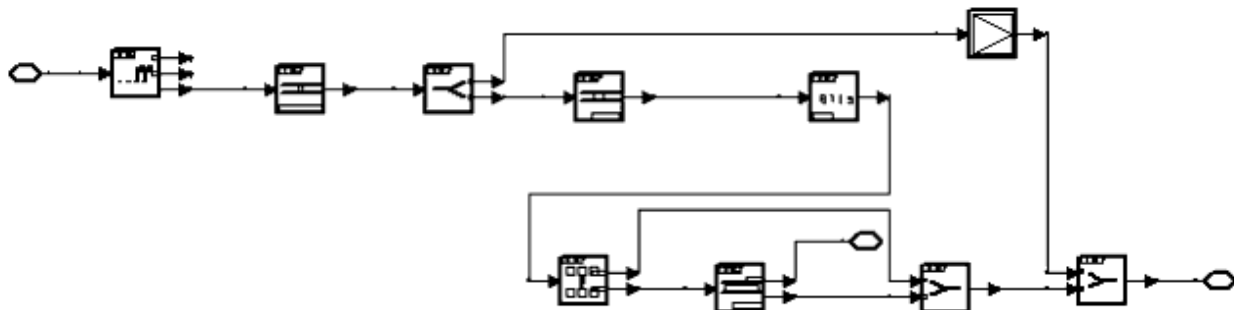

## GSM\_TCHFS\_Decoder Subnetwork

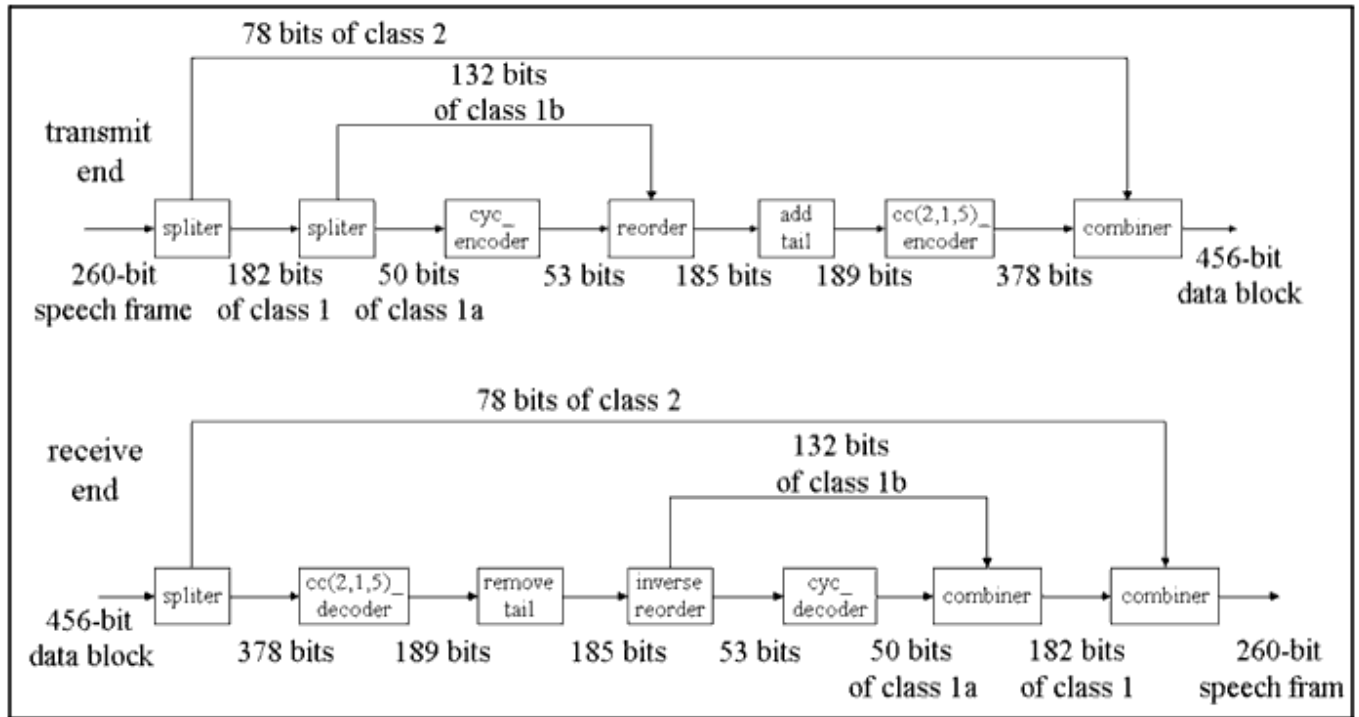

**TCH/FS Codec Data Flow**

**References**

1. European Telecommunications Standard Institute (ETSI), Rec. ETSI/GSM 05.03, *Channel Coding*, version 5.1.0, May 1996.

# GSM\_TCHFS\_Encoder



**Description:** TCH/FS Channel Encoder

**Library:** GSM, Channel Coding

**Class:** SDFGSM\_TCHFS\_Encoder

## Pin Inputs

Pin	Name	Description	Signal Type
1	input	controlling data frames	int

## Pin Outputs

Pin	Name	Description	Signal Type
2	output	channel encoded data sequences	int

## Notes/Equations

1. This subnetwork is used to encode full rate traffic channel (TCH/FS) data.
2. Implementation

This subnetwork structure is shown in [GSM\\_TCHFS\\_Encoder Subnetwork](#). It includes two splitters, a cyclic codes encoder, reorderer, a tail bits inserter, convolutional codes encoder, a combiner, and an interleaver. As shown in [TCH/FS Codec Data Flow](#), data is split by two splitters: 1a is cyclically encoded; 1b (132 bits) is not cyclically encoded. The combined 1a and 1b are the most critical bits that use half-rate convolutional coding after tail bits are added. Combined with the 78 bits of class 2, the channel coding subnetwork outputs a 456-bit data block.

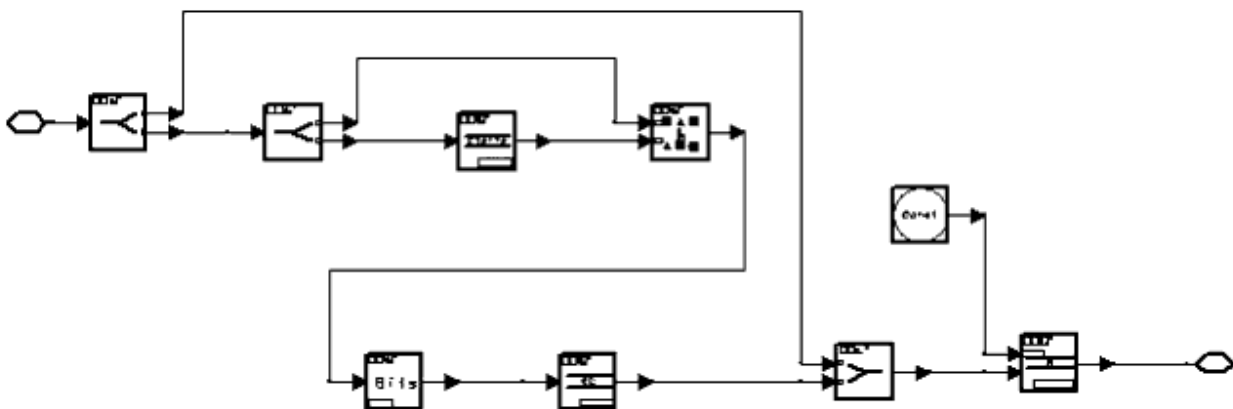

GSM\_TCHFS\_Encoder Subnetwork

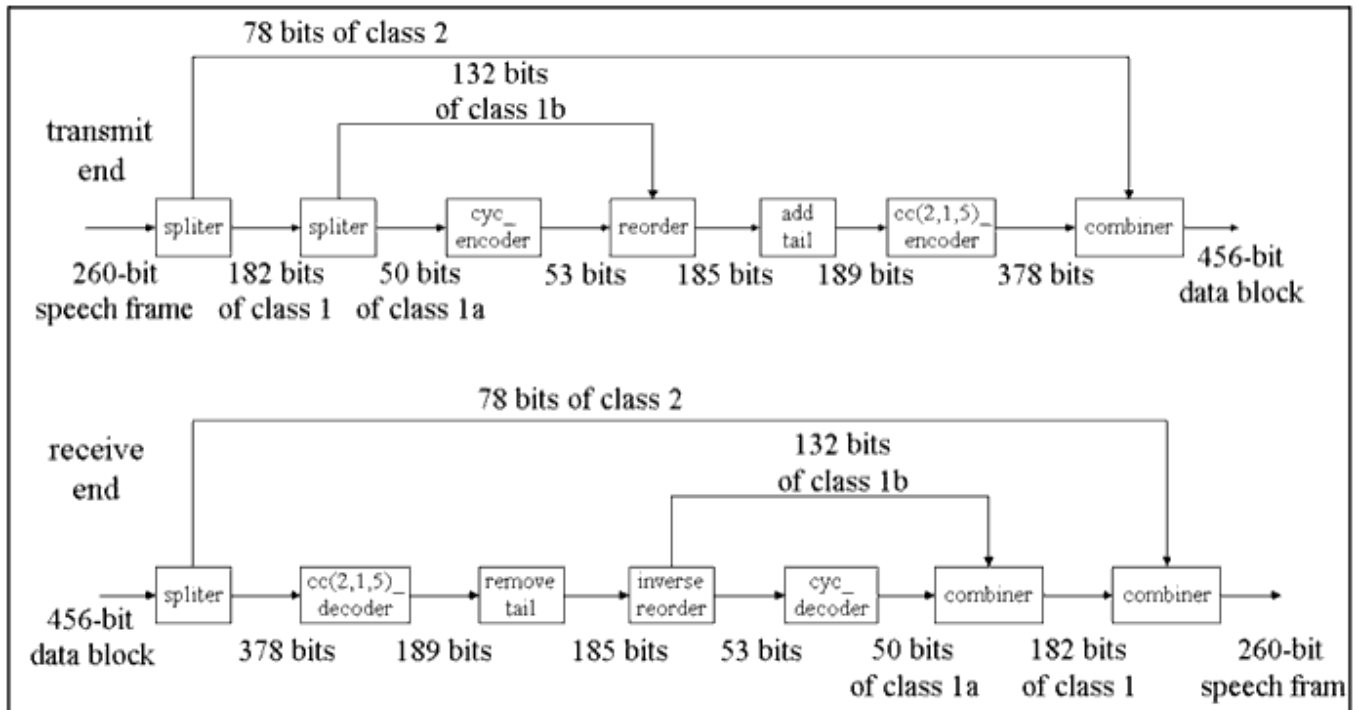

TCH/FS Codec Data Flow

## References

1. European Telecommunications Standard Institute (ETSI), Rec. ETSI/GSM 05.03, *Channel Coding*, version 5.1.0, May 1996.



# Equalization Components for GSM Design Library

- *GSM ChannelEstimator* (gsm)
- *GSM Derotator* (gsm)
- *GSM Equalizer* (gsm)
- *GSM EquCombiner* (gsm)
- *GSM EquComposeAB* (gsm)
- *GSM EquDecomposeAB* (gsm)
- *GSM EquSplitter* (gsm)
- *GSM Filter* (gsm)
- *GSM Receiver* (gsm)
- *GSM ReceiverAB* (gsm)

# GSM\_ChannelEstimator



**Description:** Channel Estimator Used in GSM Channel Equalization

**Library:** GSM, Equalization

**Class:** SDFGSM\_ChannelEstimator

## Parameters

Name	Description	Default	Unit	Type	Range
Direction	direction of estimation: Forward, Backward	Forward		enum	
BurstType	burst type: Normal Burst, Synchronization Burst, Access Burst	Normal Burst		enum	
L	maximum delay of channel, in bit duration units, Tb	5		int	[1:MAX_L] †

† MAX\_L, typically `It_equal.gif 5`, is defined in `{_}EquHeader.h`

## Pin Inputs

Pin	Name	Description	Signal Type
1	input	synchronized and derotated data	complex
2	tsc	training sequence code, defined by GSM 05.02	int

## Pin Outputs

Pin	Name	Description	Signal Type
3	output	estimate of complex channel impulse response	complex
4	index	index used to correct synchronization	int

## Notes/Equations

1. This model is used to estimate the impulse response of the equivalent channel, which includes the effect of modulation and derotation.  $L+1$  output tokens are produced at pin output and one token is produced at pin index for each  $N$  input tokens consumed at pin input and one token consumed at pin tsc, where  $N$  is frame length (see [Frame Length N Value](#)).

### Frame Length N Value

<b>N</b>	<b>BurstType</b>
$87 + 2 \times L$	Normal Burst
$106 + 2 \times L$	Synchronization Burst
$80 + 2 \times L$	Access Burst

## References

1. R. Steele, *Mobile Radio Communications*, London: Pentech Press, 1992.
2. European Telecommunications Standard Institute (ETSI), Rec. ETSI/GSM 05.02, *Multiplexing and Multiple Access on the Radio Path*, version 4.8.0, Nov. 1996.

# GSM\_Derotator



**Description:** Derotator Used in Equalization

**Library:** GSM, Equalization

**Class:** SDFGSM\_Derotator

## Pin Inputs

Pin	Name	Description	Signal Type
1	input	input data sequence	complex

## Pin Outputs

Pin	Name	Description	Signal Type
2	output	output data sequence	complex

## Notes/Equations/References

1. This model is used to derotate the received GMSK signals to compensate for rotation introduced by GMSK modulation. 156 output tokens are produced for each 156 input tokens consumed at the input.
2. Implementation  
The GMSK modulation introduces a rotation in the signal phase- the  $\pi/2$  increase or decrease of the phase in each bit duration. Removing this phase rotation before the matched filter can simplify subsequent processes.

# GSM\_Equalizer



**Description:** Adaptive Channel Equalizer with Matched Filter

**Library:** GSM, Equalization

**Class:** SDFGSM\_Equalizer

## Parameters

Name	Description	Default	Symbol	Unit	Type	Range
BurstType	burst type: Normal Burst, Synchronization Burst, Access Burst	Normal Burst			enum	
L	maximum delay of channel in unit of $T_b$ , the bit duration	5			int	[1:MAX_L] †
TrackingFlag	tracking option: Not Tracking, Tracking	Not Tracking			enum	
TrackingStart	start position of tracking	26			int	[L:frameLength-L] ††
S_Step	step-size gain used in adjusting $s$ , the equivalent channel coefficients	0.0	$\alpha_s$		real	[0, $\infty$ )
G_Step	step-size gain used in adjusting $g$ , the matched filter taps	0.0	$\alpha_g$		real	[0, $\infty$ )

† MAX\_L, typically  $\leq 5$ , is defined in *EquHeader.h*

†† frameLength = 87 + 2L if BurstType = Normal Burst

frameLength = 106 + 2L if BurstType = Synchronization Burst

frameLength = 80 + 2L if BurstType = Access Burst

## Pin Inputs

Pin	Name	Description	Signal Type
1	input	derotated signal, one sample per bit	complex
2	index	index used to correct synchronization	int
3	chnl	estimate of complex channel	complex

## Pin Outputs

Pin	Name	Description	Signal Type
4	output	equalized data	real

## Notes/Equations

1. This model is used to adaptively equalize received data. N output tokens are produced at pin output for each N input token consumed at pin input, L+1 input tokens consumed at pin chnl and one token consumed at pin index, where N is frame length (see [Frame Length N Value](#)).

#### Frame Length N Value

<b>N</b>	<b>BurstType</b>
$87 + 2 \times L$	Normal Burst
$106 + 2 \times L$	Synchronization Burst
$80 + 2 \times L$	Access Burst

#### 2. Implementation

This model includes a matched filter and a Viterbi processor.

The matched filter is used before the Viterbi processor to establish an optimum signal-to-noise ratio. The number of taps of the matched filter is (L+1). In training mode, the matched filter gets its tap coefficients from GSM\_ChannelEstimator, which are the complex conjugates of the reverse sequence of the estimated channel impulse response coefficients. In tracking mode, the matched filter establishes an optimum signal-to-noise ratio of its output signals, while adjusting its tap gains adaptively by a gradient algorithm.

The Viterbi processor uses a modified Viterbi algorithm [1] that operates directly on the matched filter output without whitening the noise.

If TrackingFlag is set to Tracking, the entire sequence is equalized without tracking, then equalized again using the tracking algorithm and the results of the first equalization. From this, the tracking performance band can be obtained.

The index input is used on the results of the Viterbi processor to further correct the synchronization. The results are output from the offset of the value of index and zeros are added to the end.

#### References

1. G. Ungerboeck, *Adaptive maximum-likelihood receiver for carrier-modulated data-transmission system*, IEEE Trans. Commun., vol. COM-22, pp. 624-636, May 1974.
2. R. D'Avella, L. Moreno, M. Sant'Agostion, *An adaptive MLSE receiver for TDMA digital mobile radio*, IEEE Jour. on SAC, vol. 7, No. 1, pp. 122-129, Jan 1989.
3. P. Qinhu, G. Yong, L. Weidong, *Synchronization design theory of demodulation for digital land mobile radio system*, Jour. of Beijing University of Posts and Telecommunications, vol. 18, No. 2, pp. 14-21, Jun 1995.

# GSM\_EquCombiner



**Description:** Combiner Used in Bidirectional Equalization

**Library:** GSM, Equalization

**Class:** SDFGSM\_EquCombiner

## Parameters

Name	Description	Default	Unit	Type	Range
BurstType	burst type: Normal Burst, Synchronization Burst	Normal Burst		enum	
L	maximum delay of channel in unit of $T_b$ , the bit duration	5		int	[1:MAX_L] †

† MAX\_L, typically  $\leq 5$ , is defined in *EquHeader.h*

## Pin Inputs

Pin	Name	Description	Signal Type
1	fwd	forward frame	real
2	bkwd	backward frame	real

## Pin Outputs

Pin	Name	Description	Signal Type
3	output	combined burst	real

## Notes/Equations

- This model is used to combine two input frames to a burst. 156 output tokens are produced for each N input token consumed at pins fwd and bkwd, where N is frame length given in [Value of frame length N](#).

### Value of frame length N

N	BurstType
$87 + 2 \times L$	Normal Burst
$106 + 2 \times L$	Synchronization Burst

- Implementation  
Two input frames are combined to form a burst. [Bidirectional Equalization for Normal Burst](#) shows the split of a normal burst. Implementation of the synchronization burst is the same except for the length of training sequence, which is 64 bits. The forward frame starts from the beginning of the training sequence and ends at the end of the

burst; the backward frame starts from the end of the training sequence and ends at the beginning of the burst. Since both frames contain a training sequence, only one of the training sequences ([Bidirectional Equalization for Normal Burst](#) shows the forward frame) is embedded in the resulting burst. 8 bits of 0 are added to the end of guard bits to form a normal burst.

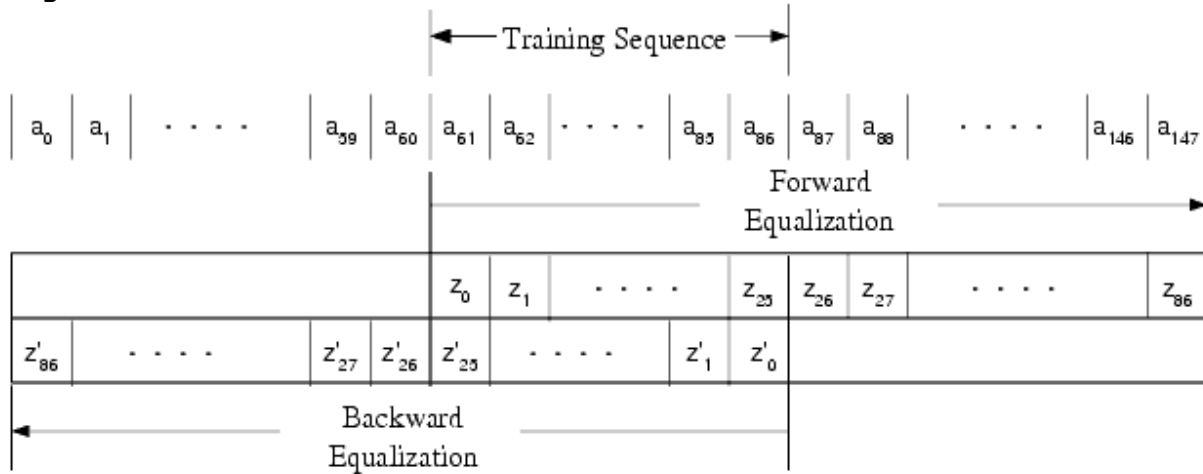

**Bidirectional Equalization for Normal Burst**

**References**

1. European Telecommunications Standard Institute (ETSI), Rec. ETSI/GSM 05.02, *Multiplexing and Multiple Access on the Radio Path*, version 4.8.0, Nov. 1996.



# GSM\_EquComposeAB



**Description:** Burst Composer of Access Burst in Equalization

**Library:** GSM, Equalization

**Class:** SDFGSM\_EquComposeAB

## Parameters

Name	Description	Default	Unit	Type	Range
L	maximum delay of channel in unit of $T_b$ , the bit duration	5		int	[1:MAX_L] †

† MAX\_L, typically  $\leq 5$ , is defined in *EquHeader.h*

## Pin Inputs

Pin	Name	Description	Signal Type
1	input	equalized synchronizaiton and information sequence	real

## Pin Outputs

Pin	Name	Description	Signal Type
2	output	output burst	real

## Notes/Equations

1. This model is used to compose the Access Burst in equalization. 156 output tokens are produced for each  $80+2 \times L$  input tokens are consumed at pin input.
2. Implementation  
The structure of Access Burst is shown in [Access Burst Structure](#). There are eight extended tail bits, a synchronization sequence, an information sequence, three tail bits equal to 0 and an extended guard sequence. The extended tail bits, synchronization sequence and the extended guard sequence are defined in reference [1]; the information sequence is defined in reference [2]. This model receives the synchronization and information sequences with tail bits considering the spread of the channel and the matched filter, and composes the resulting burst by adding extended tail bits and filling the guard period with not return to zero signal 1, which is mapping to the logical signal 0.

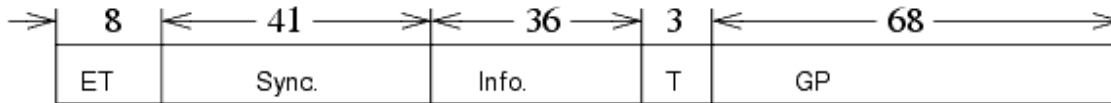

ET: Extended Tail bits

Sync.: Synchronization sequence

Info.: Information sequence

T: Tail bits

GP: Guard Period

### Access Burst Structure

### References

1. European Telecommunications Standard Institute (ETSI), Rec. ETSI/GSM 05.02, *Multiplexing and Multiple Access on the Radio Path*, version 4.8.0, Nov. 1996.
2. European Telecommunications Standard Institute (ETSI), Rec. ETSI/GSM 05.03, *Channel Coding*, version 5.1.0, May 1996.

# GSM\_EquDecomposeAB



**Description:** Burst Decomposer of Access Burst in Equalization

**Library:** GSM, Equalization

**Class:** SDFGSM\_EquDecomposeAB

## Parameters

Name	Description	Default	Unit	Type	Range
L	maximum delay of channel in unit of $T_b$ , the bit duration	5		int	[1:MAX_L] †

† MAX\_L, typically  $\leq 5$ , is defined in *EquHeader.h*

## Pin Inputs

Pin	Name	Description	Signal Type
1	input	input burst	complex

## Pin Outputs

Pin	Name	Description	Signal Type
2	output	output synchronization and information sequence	complex

## Notes/Equations

1. This model is used to decompose the Access Burst in equalization.  $80+2 \times L$  output tokens are produced for each 156 input tokens consumed at pin input.
2. Implementation  
The structure of Access Burst is shown as [Access Burst Structure](#). There are eight extended tail bits, a synchronization sequence, an information sequence, three tail bits equal to 0 and an extended guard sequence. The extended tail bits, synchronization sequence and the extended guard sequence are defined in reference [1]; the information sequence is defined in reference [2]. This model receives the whole bit synchronized and derotated burst, and outputs the synchronization and information sequences with tail bits considering the spread of the channel and the matched filter.

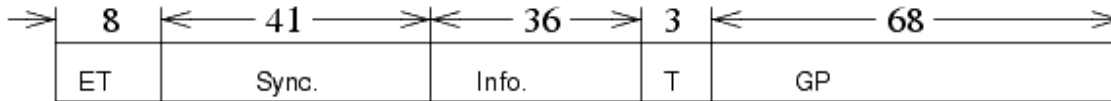

ET: Extended Tail bits

Sync.: Synchronization sequence

Info.: Information sequence

T: Tail bits

GP: Guard Period

### Access Burst Structure

### References

1. European Telecommunications Standard Institute (ETSI), Rec. ETSI/GSM 05.02, *Multiplexing and Multiple Access on the Radio Path*, version 4.8.0, Nov. 1996.
2. European Telecommunications Standard Institute (ETSI), Rec. ETSI/GSM 05.03, *Channel Coding*, version 5.1.0, May 1996.

# GSM\_EquSplitter



**Description:** Splitter Used in Bidirectional Equalization

**Library:** GSM, Equalization

**Class:** SDFGSM\_EquSplitter

## Parameters

Name	Description	Default	Unit	Type	Range
BurstType	burst type: Normal Burst, Synchronization Burst	Normal Burst		enum	
L	Mmaximum delay of channel in unit of $T_b$ , the bit duration	5		int	[1:MAX_L] †

† MAX\_L, typically  $\leq 5$ , is defined in *EquHeader.h*

## Pin Inputs

Pin	Name	Description	Signal Type
1	input	input burst	complex

## Pin Outputs

Pin	Name	Description	Signal Type
2	fwd	forward frame	complex
3	bkwd	backward frame	complex

## Notes/Equations

1. This model is used to split one burst into two frames. For each 156 input tokens are consumed at pin input, N output tokens at the fwd and bkwd pins are produced, where N is frame length (refer to [Value of Frame Length N](#)).

### Value of Frame Length N

N	BurstType
$87 + 2 \times L$	Normal Burst
$106 + 2 \times L$	Synchronization Burst

2. Implementation

This model splits one burst into two frames, as shown in [Bidirectional Equalization and Normal Burst](#). The forward burst starts from the beginning of the training sequence and ends at the end of the burst; the backward burst starts at the end of the training sequence and ends at the beginning of the burst. Zeros are added to

each frame to reserve space for spreading signals introduced by the following matched filter. The number of zeros is determined by parameter L, the maximum delay of the channel. By considering the spreading of signals transmitted through the channel, backward equalization starts at the Lth bit following the end of training sequence in the implementation of this component. [Bidirectional Equalization and Normal Burst](#) shows the split of a normal burst; implementation of a synchronization burst is the same except for the length of the training sequence, which is 64 bits.

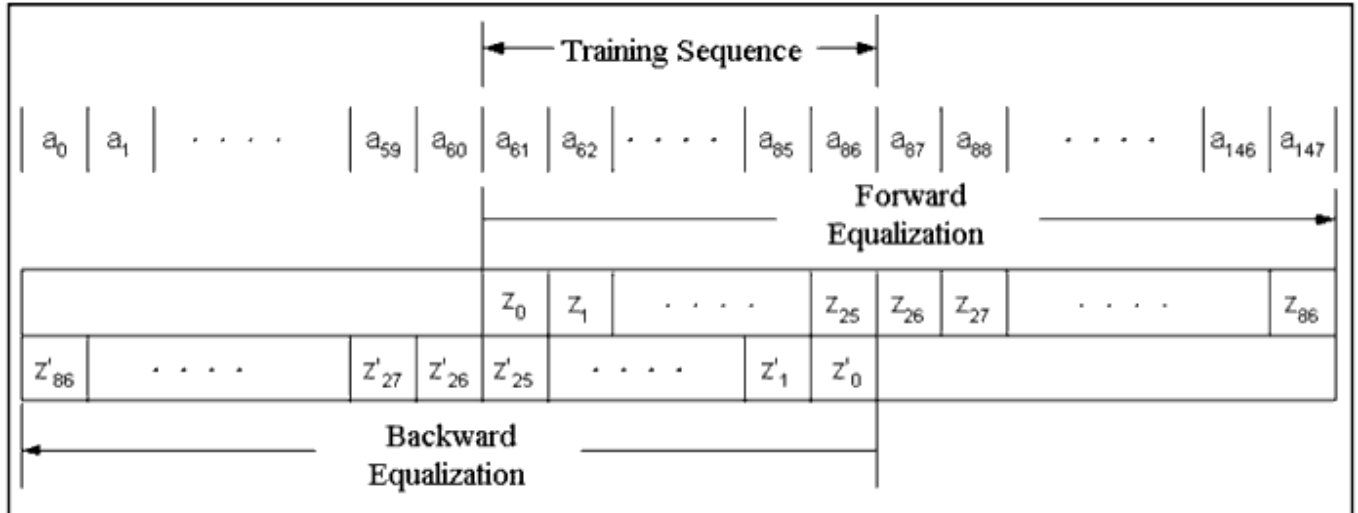

**Bidirectional Equalization and Normal Burst**

**References**

1. European Telecommunications Standard Institute (ETSI), Rec. ETSI/GSM 05.02, *Multiplexing and Multiple Access on the Radio Path*, version 4.8.0, Nov. 1996.

# GSM\_Filter



**Description:** 7-Pole Chebychev Filter

**Library:** GSM, Equalization

**Class:** SDFGSM\_Filter

## Pin Inputs

Pin	Name	Description	Signal Type
1	input	modulated signal that has passed through the channel	real

## Pin Outputs

Pin	Name	Description	Signal Type
2	output	filtered baseband signal	real

## Notes/Equations

1. This subnetwork is a 7-pole Chebychev filter that is used as a baseband filter in the GSM receiver.
2. Implementation

This subnetwork is designed by Digital Filter Designer of Agilent's Advanced Design System. The 3 dB bandwidth is 100 kHz. [GSM\\_Filter Subnetwork](#) shows the subnetwork structure.

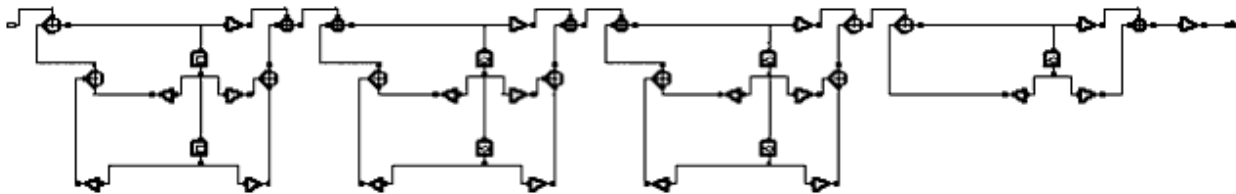

[GSM\\_Filter Subnetwork](#)

## References

1. S. M. Redl, Matthias, M. W. Oliphant, *An Introduction To GSM*, Artech House Publishers, 1995.

# GSM\_Receiver



**Description:** Adaptive MLSE Receiver

**Library:** GSM, Equalization

**Class:** SDFGSM\_Receiver

## Parameters

Name	Description	Default	Symbol	Unit	Type	Range
TSC	training sequence code	0			int	[0:7]
BurstType	burst type: Normal Burst, Synchronization Burst	Normal Burst			enum	
L	maximum delay of channel in unit of $T_b$ , the bit duration	5			int	[1:MAX_L] †
TrackingFlag	tracking option: Not Tracking, Tracking	Not Tracking			enum	
TrackingStart	start position of tracking	26			int	[L:frameLength-L] ††
S_Step	step-size gain used in adjusting $s$ , the equivalent channel coefficients	0.0	$\alpha_s$		real	[0, $\infty$ )
G_Step	step-size gain used in adjusting $g$ , the matched filter taps	0.0	$\alpha_g$		real	[0, $\infty$ )

† MAX\_L, typically  $\leq 5$ , is defined in *EquHeader.h*

†† if BurstType=Normal Burst, frameLength=87+2L

if BurstType=Synchronization Burst, frameLength=106+2L.

## Pin Inputs

Pin	Name	Description	Signal Type
1	input	input data sequence	complex

## Pin Outputs

Pin	Name	Description	Signal Type
2	output	combined burst	real

## Notes/Equations

1. This subnetwork is used to restore the data sequence from the received and synchronized signals.
2. Implementation  
The construction of this subnetwork is shown in [Viterbi Adaptive Receiver Block](#)

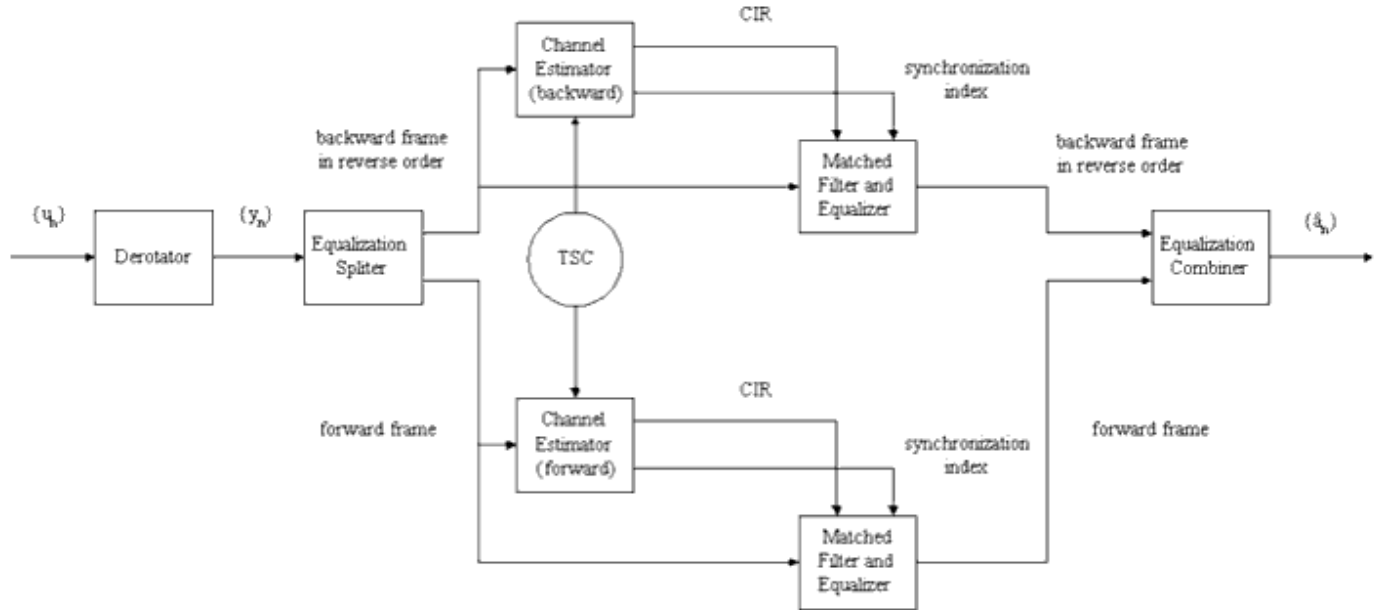

**Diagram.**

$\{u_n\}$  is the received signals samples, one sample per bit.

$\{\hat{a}_n\}$  is the equalized data.

The input data is derotated to demodulate GMSK modulation. It is split into a forward and a backward subframe in reverse order for the training sequence that is in the middle of the input frame. Both subframes are weighted with the channel estimates obtained using the training sequence and equalized with a modified Viterbi algorithm. The equalized subframes are then combined into one frame.



**Viterbi Adaptive Receiver Block Diagram**

**References**

1. European Telecommunications Standard Institute (ETSI), Rec. ETSI/GSM 05.03, *Channel Coding*, version 5.1.0, May 1996.
2. R. Steele, *Mobile Radio Communications*, London: Pentech Press, 1992.
3. European Telecommunications Standard Institute (ETSI), Rec. ETSI/GSM 05.02, *Multiplexing and Multiple Access on the Radio Path*, version 4.8.0, Nov. 1996.
4. G. Ungerboeck, *Adaptive maximum-likelihood receiver for carrier-modulated data-transmission system*, IEEE Trans. Commun., vol. COM-22, May 1974, pp. 624-636.
5. R. D'Avella, L. Moreno, M. Sant'Agostino, *An adaptive MLSE receiver for TDMA digital mobile radio*, IEEE J. Select. Areas Commun., vol. 7, Jan. 1989, pp. 122-129.

## GSM\_ReceiverAB



**Description:** Adaptive MLSE Receiver for Access Burst

**Library:** GSM, Equalization

**Class:** SDFGSM\_ReceiverAB

### Parameters

Name	Description	Default	Unit	Type	Range
L	maximum delay of channel in unit of $T_b$ , the bit duration	5		int	[1:MAX_L] †

† MAX\_L, typically  $\leq 5$ , is defined in *EquHeader.h*

### Pin Inputs

Pin	Name	Description	Signal Type
1	input	input data sequence	complex

### Pin Outputs

Pin	Name	Description	Signal Type
2	output	combined burst	real

### Notes/Equations

1. This subnetwork is used to restore the data sequence from the received and synchronized signals of access burst.

2. Implementation

The construction of this subnetwork is shown in [Viterbi Adaptive Receiver for Access Burst Block Diagram](#).

$\{u_n\}$  is the received signals samples, one sample per bit.

$\{\hat{a}_n\}$  is the equalized data.

Input data is split into synchronization and information sequences after de-rotation. The synchronization sequence is used for calculating channel estimates with which the information sequence is equalized. The synchronization and equalized information sequences are combined.

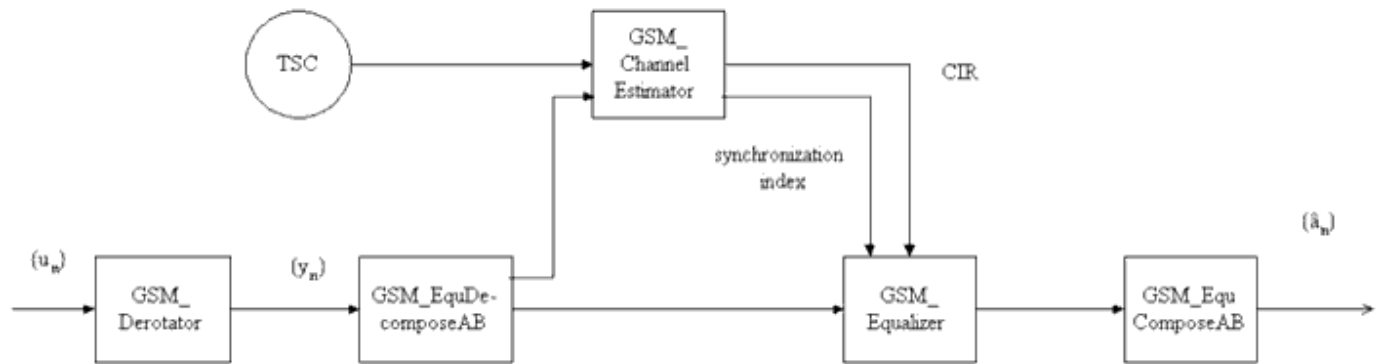

**Viterbi Adaptive Receiver for Access Burst Block Diagram**

## References

1. European Telecommunications Standard Institute (ETSI), Rec. ETSI/GSM 05.03, *Channel Coding*, version 5.1.0, May 1996.
2. R. Steele, *Mobile Radio Communications*, London: Pentech Press, 1992.
3. European Telecommunications Standard Institute (ETSI), Rec. ETSI/GSM 05.02, *Multiplexing and Multiple Access on the Radio Path*, version 4.8.0, Nov. 1996.
4. G. Ungerboeck, *Adaptive maximum-likelihood receiver for carrier-modulated data-transmission system*, IEEE Trans. Commun., vol. COM-22, May 1974, pp. 624-636.
5. R. D'Avella, L. Moreno, M. Sant'Agostino, *An adaptive MLSE receiver for TDMA digital mobile radio*, IEEE J. Select. Areas Commun., vol. 7, Jan. 1989, pp. 122-129.

# Framing Components for GSM Design Library

- *GSM AccessBurst* (gsm)
- *GSM BcchCcch4SdcchDn* (gsm)
- *GSM BcchCcch4SdcchUp* (gsm)
- *GSM BcchCcchDn* (gsm)
- *GSM BcchCcchUp* (gsm)
- *GSM DeAccessBurst* (gsm)
- *GSM DeBcchCcch4SdcchDn* (gsm)
- *GSM DeBcchCcch4SdcchUp* (gsm)
- *GSM DeBcchCcchDn* (gsm)
- *GSM DeMultiframe26* (gsm)
- *GSM DeNormalBurst* (gsm)
- *GSM DeSBurst* (gsm)
- *GSM DeSdcch8Dn* (gsm)
- *GSM DeSdcch8Up* (gsm)
- *GSM DeTDMA* (gsm)
- *GSM DummyBurst* (gsm)
- *GSM FBurst* (gsm)
- *GSM Multiframe26* (gsm)
- *GSM NormalBurst* (gsm)
- *GSM SBurst* (gsm)
- *GSM Sdcch8Dn* (gsm)
- *GSM Sdcch8Up* (gsm)
- *GSM TDMA* (gsm)
- *GSM TimeBaseCounter* (gsm)

# GSM\_AccessBurst



**Description:** Access Burst Construction

**Library:** GSM, Framing

**Class:** SDFGSM\_AccessBurst

## Pin Inputs

Pin	Name	Description	Signal Type
1	input	36 encrypted bits	int

## Pin Outputs

Pin	Name	Description	Signal Type
2	output	156 modulating bits including 8-bit guarding period	int

## Notes/Equations

1. This model is used to construct an access burst of 156 bits defined in GSM standard 05.02.

156 output tokens are produced for each 36 encrypted tokens consumed.

2. Implementation

[Access Burst Structure](#) shows the access burst structure. The synchronization sequence is defined as

(BN8, BN9, ... , BN48) =

(0,1,0,0,1,0,1,1,0,1,1,1,1,1,1,1,0,0,1,1,0,0,1,1,0,1,0,1,0,1,0,0,0, 1,1,1,1,0,0,0)

TB 8	Synchronisation Sequence 41	Encrypted Bits 36	TB 3	GP 68
---------	--------------------------------	----------------------	---------	----------

## Access Burst Structure

## References

1. European Telecommunications Standard Institute (ETSI), Rec. ETSI/GSM 05.02, *Multiplexing and Multiple Access on the Radio Path*, version 3.5.1, March 1992.

# GSM\_BcchCcch4SdcchDn



**Description:** BCCH+CCCH+4SDCCH Downlink Construction

**Library:** GSM, Framing

**Class:** SDFGSM\_BcchCcch4SdcchDn

## Pin Inputs

Pin	Name	Description	Signal Type
1	SCH	SCH Signal	int
2	BCCH	BCCH Signal	int
3	CCCH	CCCH signal	int
4	SACCH	SACCH signal	int
5	SDCCH	SDCCH Signal	int

## Pin Outputs

Pin	Name	Description	Signal Type
6	output	51-frame multiframe of BCCH+CCCH+4SDCCH downlink	int

## Notes/Equations

- This model is used to construct a BCCH+CCCH+4SDCCH downlink 51-frame multiframe as defined in GSM 05.02 standard.  
 $51 \times 8 \times 156$  output tokens are produced for each input set of tokens consumed.  
 SCH:  $4 \times 8 \times 156$  tokens are consumed each firing.  
 BCCH:  $4 \times 8 \times 156$  tokens are consumed each firing.  
 CCCH:  $12 \times 8 \times 156$  tokens are consumed each firing.  
 SACCH:  $8 \times 8 \times 156$  tokens are consumed each firing.  
 SDCCH:  $16 \times 8 \times 156$  tokens are consumed each firing.

### 2. Implementation

[BCCH+CCCH+4 SDCCH/4 Downlink Structure](#) shows the structure of a 51-frame multiframe BCCH+CCCH downlink.

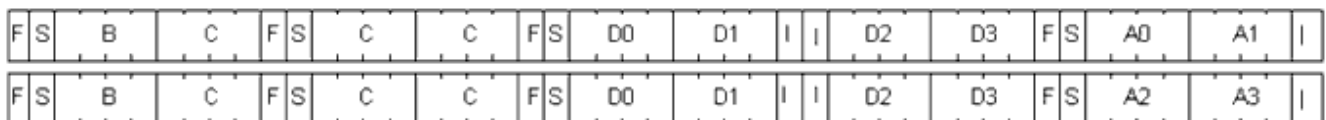

A=SACCH, B=BCCH, C=CCCH, D=SDCCH

F=frequency correction burst, S=synchronization burst

**BCCH+CCCH+4 SDCCH/4 Downlink Structure**

**References**

1. European Telecommunications Standard Institute (ETSI), Rec. ETSI/GSM 05.02, *Multiplexing and Multiple Access on the Radio Path*, version 3.5.1, March 1992.

# GSM\_BcchCcch4SdcchUp



**Description:** BCCH+CCCH+4SDCCH Uplink Construction

**Library:** GSM, Framing

**Class:** SDFGSM\_BcchCcch4SdcchUp

## Pin Inputs

Pin	Name	Description	Signal Type
1	RACH	RACH signal	int
2	SACCH	SACCH signal	int
3	SDCCH	SDCCH signal	int

## Pin Outputs

Pin	Name	Description	Signal Type
4	output	51-frame multiframe of BCCH+CCCH+4SDCCH uplink	int

## Notes/Equations

- This model is used to construct a BCCH+CCCH+4 SDCCH/4 51-frame multiframe uplink as defined in GSM 05.02 standard.  
 $51 \times 8 \times 156$  output tokens are produced for each input set of tokens consumed.  
 RACH:  $27 \times 8 \times 156$  tokens are consumed each firing.  
 SACCH:  $8 \times 156$  tokens are consumed each firing.  
 SDCCH:  $16 \times 8 \times 156$  tokens are consumed each firing.
- Implementation  
[BCCH+CCCH+4SDCCH Uplink Structure](#) shows a BCCH+CCCH+4 SDCCH/4 51-frame multiframe uplink structure.

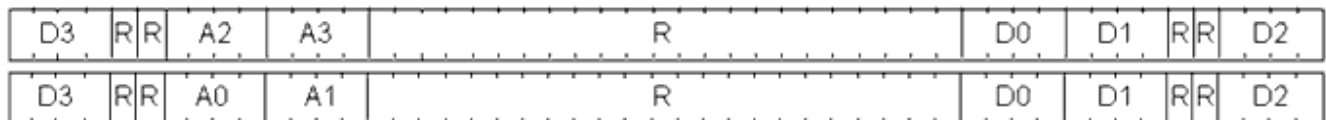

D=SDCCH, A=SACCH, R=RACH

All data is transferred in timeslot 0(TN=0)

## BCCH+CCCH+4SDCCH Uplink Structure



## References

1. European Telecommunications Standard Institute (ETSI), Rec. ETSI/GSM 05.02, *Multiplexing and Multiple Access on the Radio Path*, version 3.5.1, March 1992.
2. European Telecommunications Standard Institute (ETSI), Rec. ETSI/GSM 03.03, *Numbering, addressing and identification*, version 3.5.1, March 1992.
3. European Telecommunications Standard Institute (ETSI), Rec. ETSI/GSM 04.03, *Mobile Station - Base Station System (MS - BSS) interface Channel structures and access capabilities*, version 3.5.1, March 1992.

# GSM\_BcchCcchDn



**Description:** BCCH+CCCH Downlink Construction

**Library:** GSM, Framing

**Class:** SDFGSM\_BcchCcchDn

## Pin Inputs

Pin	Name	Description	Signal Type
1	SCH	SCH signal	int
2	BCCH	BCCH signal	int
3	CCCH	CCCH signal	int

## Pin Outputs

Pin	Name	Description	Signal Type
4	output	51-frame multiframe of BCCH+CCCH downlink	int

## Notes/Equations

- This model is used to construct a BCCH+CCCH downlink 51-frame multiframe as defined in GSM 05.02 standard.  
 $51 \times 8 \times 156$  output tokens are produced for each input set of tokens consumed.  
 SCH:  $5 \times 8 \times 156$  tokens are consumed each firing.  
 BCCH:  $4 \times 8 \times 156$  tokens are consumed each firing.  
 CCCH:  $36 \times 8 \times 156$  tokens are consumed each firing.

- Implementation

[BCCH+CCCH Downlink Structure](#) shows structure of a 51-frame multiframe BCCH+CCCH downlink.



F=frequency correction burst, S=synchronization burst  
 B=BCCH, C=CCCH

## BCCH+CCCH Downlink Structure

## References

1. European Telecommunications Standard Institute (ETSI), Rec. ETSI/GSM 05.02, vMultiplexing and Multiple Access on the Radio Path\_, version 3.5.1, March 1992.
2. European Telecommunications Standard Institute (ETSI), Rec. ETSI/GSM 03.03, *Numbering, addressing and identification*, version 3.5.1, March 1992.
3. European Telecommunications Standard Institute (ETSI), Rec. ETSI/GSM 04.03, *Mobile Station - Base Station System (MS - BSS) interface Channel structures and access capabilities*, version 3.5.1, March 1992.

# GSM\_BcchCcchUp



**Description:** BCCH+CCCH Uplink Construction

**Library:** GSM, Framing

**Class:** SDFGSM\_BcchCcchUp

## Pin Inputs

Pin	Name	Description	Signal Type
1	input	RACH signal	int

## Pin Outputs

Pin	Name	Description	Signal Type
2	output	51-frame multiframe of BCCH+CCCH uplink	int

## Notes/Equations

1. This model is used to construct a BCCH+CCCH uplink 51-frame multiframe as defined in GSM 05.02 standard. One output token is produced for one input token consumed.
2. Implementation  
[BCCH+CCCH Uplink Structure](#) shows structure of 51-frame multiframe BCCH+CCCH uplink.

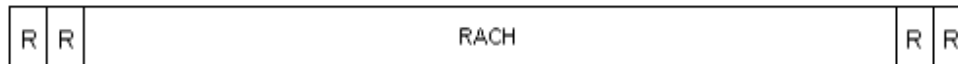

R=random access burst

## BCCH+CCCH Uplink Structure

## References

1. European Telecommunications Standard Institute (ETSI), Rec. ETSI/GSM 05.02, *Multiplexing and Multiple Access on the Radio Path*, version 3.5.1, March 1992.
2. European Telecommunications Standard Institute (ETSI), Rec. ETSI/GSM 03.03, *Numbering, addressing and identification*, version 3.5.1, March 1992.
3. European Telecommunications Standard Institute (ETSI), Rec. ETSI/GSM 04.03, *Mobile Station - Base Station System (MS - BSS) interface Channel structures and access capabilities*, version 3.5.1, March 1992.

# GSM\_DeAccessBurst



**Description:** Access Burst Disassembly

**Library:** GSM, Framing

**Class:** SDFGSM\_DeAccessBurst

## Pin Inputs

Pin	Name	Description	Signal Type
1	input	156 bits of access burst	real

## Pin Outputs

Pin	Name	Description	Signal Type
2	output	36 encrypted bits	real

## Notes/Equations/References

- This model is used to disassemble the access burst as defined in GSM 05.02 standard.  
36 output tokens are produced for each 156 tokens consumed.
- Implementation  
[Access Burst Structure](#) shows the access burst structure.

TB 8	Synchronisation Sequence 41	Encrypted Bits 36	TB 3	GP 68
---------	--------------------------------	----------------------	---------	----------

## Access Burst Structure

## References

- European Telecommunications Standard Institute (ETSI), Rec. ETSI/GSM 05.02, *Multiplexing and Multiple Access on the Radio Path*, version 3.5.1, March 1992.
- European Telecommunications Standard Institute (ETSI), Rec. ETSI/GSM 03.03, *Numbering, addressing and identification*, version 3.5.1, March 1992.
- European Telecommunications Standard Institute (ETSI), Rec. ETSI/GSM 04.03, *Mobile Station - Base Station System (MS - BSS) interface Channel structures and access capabilities*, version 3.5.1, March 1992.

# GSM\_DeBcchCcch4SdcchDn

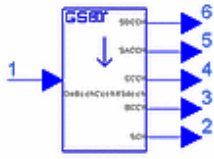

**Description:** BCCH+CCCH+4SDCCH Downlink Disassembly

**Library:** GSM, Framing

**Class:** SDFGSM\_DeBcchCcch4SdcchDn

## Pin Inputs

Pin	Name	Description	Signal Type
1	input	51-frame multiframe	real

## Pin Outputs

Pin	Name	Description	Signal Type
2	SCH	SCH signal	real
3	BCCH	BCCH signal	real
4	CCCH	CCCH signal	real
5	SACCH	SACCH signal	real
6	SDCCH	SDCCH signal	real

## Notes/Equations/References

- This model is used to disassemble the BCCH+CCCH+4 SDCCH/4 downlink as defined in GSM 05.02 standard.

51×8×156 input tokens are consumed each firing.

SCH: 27×8×156 output tokens are produced for each input set of tokens consumed.

BCCH: 4×8×156 output tokens are produced for each input set of tokens consumed.

CCCH: 12×8×156 output tokens are produced for each input set of tokens consumed.

SACCH: 8×8×156 output tokens are produced for each input set of tokens consumed.

SDCCH: 16×8×156 output tokens are produced for each input set of tokens consumed.

- Implementation

[BCCH+CCCH+4 SDCCH/4 Downlink Structure](#) shows structure of 51-frame multiframe BCCH+CCCH+4SDCCH downlink.



D=SDCCH, A=SACCH, B=BCCH, C=CCCH

F=frequency correction burst, S=synchronization burst

## BCCH+CCCH+4 SDCCH/4 Downlink Structure

### References

1. European Telecommunications Standard Institute (ETSI), Rec. ETSI/GSM 05.02, *Multiplexing and Multiple Access on the Radio Path*, version 3.5.1, March 1992.
2. European Telecommunications Standard Institute (ETSI), Rec. ETSI/GSM 03.03, *Numbering, addressing and identification*, version 3.5.1, March 1992.
3. European Telecommunications Standard Institute (ETSI), Rec. ETSI/GSM 04.03, *Mobile Station - Base Station System (MS - BSS) interface Channel structures and access capabilities*, version 3.5.1, March 1992.

# GSM\_DeBcchCcch4SdcchUp



**Description:** BCCH+CCCH+4SDCCH Uplink Disassembly

**Library:** GSM, Framing

**Class:** SDFGSM\_DeBcchCcch4SdcchUp

## Pin Inputs

Pin	Name	Description	Signal Type
1	input	51-frame multiframe	real

## Pin Outputs

Pin	Name	Description	Signal Type
2	RACH	RACH signal	real
3	SACCH	SACCH signal	real
4	SDCCH	SDCCH signal	real

## Notes/Equations

- This model is used to disassemble the BCCH+CCCH+4 SDCCH/4 uplink as defined in GSM 05.02 standard.  
 $51 \times 8 \times 156$  input tokens are consumed each firing.  
 RACH:  $27 \times 8 \times 156$  output tokens are produced for each input set of tokens consumed.  
 SACCH:  $8 \times 8 \times 156$  output tokens are produced for each input set of tokens consumed.  
 SDCCH:  $16 \times 8 \times 156$  output tokens are produced for each input set of tokens consumed.
- Implementation  
[BCCH+CCCH+4SDCCH Uplink Structure](#) shows structure of a 51-frame multiframe BCCH+CCCH +4SDCCH uplink.

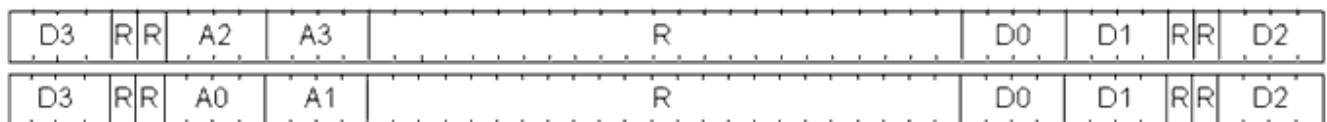

D=SDCCH, A=SACCH, R=RACH

## BCCH+CCCH+4SDCCH Uplink Structure



## References

1. European Telecommunications Standard Institute (ETSI), Rec. ETSI/GSM 05.02, *Multiplexing and Multiple Access on the Radio Path*, version 3.5.1, March 1992.
2. European Telecommunications Standard Institute (ETSI), Rec. ETSI/GSM 03.03, *Numbering, addressing and identification*, version 3.5.1, March 1992.
3. European Telecommunications Standard Institute (ETSI), Rec. ETSI/GSM 04.03, *Mobile Station - Base Station System (MS - BSS) interface Channel structures and access capabilities*, version 3.5.1, March 1992.

# GSM\_DeBcchCcchDn

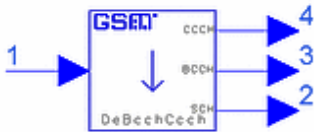

**Description:** BCCH+CCCH Downlink Disassembly

**Library:** GSM, Framing

**Class:** SDFGSM\_DeBcchCcchDn

## Pin Inputs

Pin	Name	Description	Signal Type
1	input	51-frame multiframe	real

## Pin Outputs

Pin	Name	Description	Signal Type
2	SCH	SCH signal	real
3	BCCH	BCCH signal	real
4	CCCH	CCCH signal	real

## Notes/Equations

- This model is used to disassemble a BCCH+CCCH downlink 51-frame multiframe as defined in GSM 05.02 standard.  
 $51 \times 8 \times 156$  input tokens are consumed each firing.  
 SCH:  $5 \times 8 \times 156$  output tokens are produced for each input set of tokens consumed.  
 BCCH:  $4 \times 8 \times 156$  output tokens are produced for each input set of tokens consumed.  
 CCCH:  $36 \times 8 \times 156$  output tokens are produced for each input set of tokens consumed.
- Implementation  
[BCCH+CCCH Downlink Structure](#) shows structure of 51-frame multiframe BCCH+CCCH downlink.

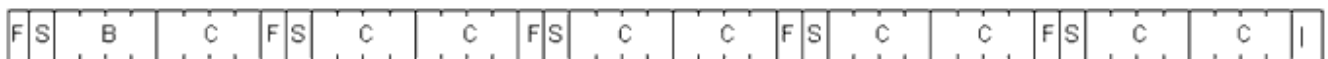

B=BCCH, C=CCCH

F=frequency correction burst, S=synchronization burst

## BCCH+CCCH Downlink Structure

## References

1. European Telecommunications Standard Institute (ETSI), Rec. ETSI/GSM 05.02, *Multiplexing and Multiple Access on the Radio Path*, version 3.5.1, March 1992.
2. European Telecommunications Standard Institute (ETSI), Rec. ETSI/GSM 03.03, *Numbering, addressing and identification*, version 3.5.1, March 1992.
3. European Telecommunications Standard Institute (ETSI), Rec. ETSI/GSM 04.03, *Mobile Station - Base Station System (MS - BSS) interface Channel structures and access capabilities*, version 3.5.1, March 1992.

# GSM\_DeMultiframe26



**Description:** 26-frame Multiframe Disassembly

**Library:** GSM, Framing

**Class:** SDFGSM\_DeMultiframe26

## Pin Inputs

Pin	Name	Description	Signal Type
1	input	26-frame mutiframe of 26*8*156 bits	real

## Pin Outputs

Pin	Name	Description	Signal Type
2	TCH	TCH signal	real
3	SACCH	SACCH signal	real

## Notes/Equations

- This model is used to disassemble 26-frame multiframe as defined in GSM 05.02 standard.  
 $26 \times 8 \times 156$  input tokens are consumed each firing.  
 TCH:  $24 \times 8 \times 156$  output tokens are produced for each input set of tokens consumed.  
 SACCH:  $8 \times 156$  output tokens are produced for each input set of tokens consumed.
- Implementation  
[26-Frame Multiframe TCH/FS Structure](#) shows structure of 26-frame multiframe TCH/FS.

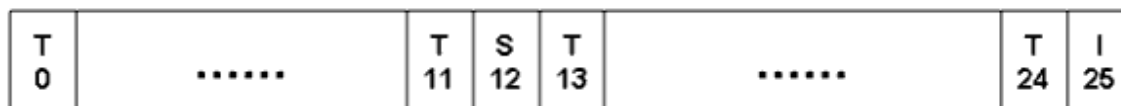

I=idle, S=SACCH, T=TCH

## 26-Frame Multiframe TCH/FS Structure

## References

- European Telecommunications Standard Institute (ETSI), Rec. ETSI/GSM 05.02, *Multiplexing and Multiple Access on the Radio Path*, version 3.5.1, March 1992.

2. European Telecommunications Standard Institute (ETSI), Rec. ETSI/GSM 03.03, *Numbering, addressing and identification*, version 3.5.1, March 1992.
3. European Telecommunications Standard Institute (ETSI), Rec. ETSI/GSM 04.03, *Mobile Station - Base Station System (MS - BSS) interface Channel structures and access capabilities*, version 3.5.1, March 1992.

# GSM\_DeNormalBurst



**Description:** Normal Burst Disassembly

**Library:** GSM, Framing

**Class:** SDFGSM\_DeNormalBurst

## Pin Inputs

Pin	Name	Description	Signal Type
1	input	156 bits of normal burst	real

## Pin Outputs

Pin	Name	Description	Signal Type
2	output	2*58 encrypted bits	real

## Notes/Equations

- This model is used to disassemble the normal burst of 156 bits defined in GSM 05.02 standard.  
2×58 output tokens are produced for each 156 tokens consumed.
- Implementation  
[Normal Burst Structure](#) shows the normal burst structure.

TB 3	Encrypted Bits 58	Training Bits 26	Encrypted Bits 58	TB 3	GP 8.25
---------	----------------------	---------------------	----------------------	---------	------------

## Normal Burst Structure

## References

- European Telecommunications Standard Institute (ETSI), Rec. ETSI/GSM 05.02, *Multiplexing and Multiple Access on the Radio Path*, version 3.5.1, March 1992.
- European Telecommunications Standard Institute (ETSI), Rec. ETSI/GSM 03.03, *Numbering, addressing and identification*, version 3.5.1, March 1992.
- European Telecommunications Standard Institute (ETSI), Rec. ETSI/GSM 04.03, *Mobile Station - Base Station System (MS - BSS) interface Channel structures and access capabilities*, version 3.5.1, March 1992.

# GSM\_DeSBurst



**Description:** Synchronization Burst Disassembly

**Library:** GSM, Framing

**Class:** SDFGSM\_DeSBurst

## Pin Inputs

Pin	Name	Description	Signal Type
1	input	synchronization burst bits	real

## Pin Outputs

Pin	Name	Description	Signal Type
2	output	encrypted bits	real

## Notes/Equations

- This model is used to disassemble a synchronization burst of 156 bits as defined in GSM 05.02 standard.  
Each firing, 156 input tokens are consumed;  $2 \times 39$  output tokens are produced for each input set of tokens consumed.
- Implementation  
[Synchronization Burst Structure](#) shows the synchronization burst structure.

TB 3	Encrypted Bits 39	Extended Training Bits 64	Encrypted Bits 39	TB 3	GP 8.25
---------	----------------------	------------------------------	----------------------	---------	------------

## Synchronization Burst Structure

## References

- European Telecommunications Standard Institute (ETSI), Rec. ETSI/GSM 05.02, *Multiplexing and Multiple Access on the Radio Path*, version 3.5.1, March 1992.
- European Telecommunications Standard Institute (ETSI), Rec. ETSI/GSM 03.03, *Numbering, addressing and identification*, version 3.5.1, March 1992.
- European Telecommunications Standard Institute (ETSI), Rec. ETSI/GSM 04.03, *Mobile Station - Base Station System (MS - BSS) interface Channel structures and access capabilities*, version 3.5.1, March 1992.

# GSM\_DeSdcch8Dn



**Description:** 8SDCCH/8 Downlink Disassembly

**Library:** GSM, Framing

**Class:** SDFGSM\_DeSdcch8Dn

## Pin Inputs

Pin	Name	Description	Signal Type
1	input	51-frame multiframe of 51*8*156 bits	real

## Pin Outputs

Pin	Name	Description	Signal Type
2	SACCH	SACCH signal	real
3	SDCCH	SDCCH signal	real

## Notes/Equations

- This model is used to disassemble an 8SDCCH/8 downlink 51-frame multiframe as defined in GSM 05.02 standard.  
 $51 \times 8 \times 156$  input tokens are consumed each firing.  
 SACCH:  $16 \times 8 \times 156$  output tokens are produced for each input set of tokens consumed.  
 SDCCH:  $32 \times 8 \times 156$  output tokens are produced for each input set of tokens consumed.
- Implementation  
[8SDCCH/8 Downlink Structure](#) shows structure of 51-frame multiframe 8SDCCH/8 downlink.

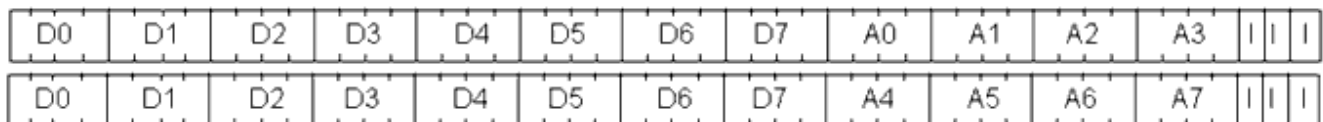

A=SACCH, D=SDCCH

|=idle frame

## 8SDCCH/8 Downlink Structure

## References



## References

1. European Telecommunications Standard Institute (ETSI), Rec. ETSI/GSM 05.02, *Multiplexing and Multiple Access on the Radio Path*, version 3.5.1, March 1992.
2. European Telecommunications Standard Institute (ETSI), Rec. ETSI/GSM 03.03, *Numbering, addressing and identification*, version 3.5.1, March 1992.
3. European Telecommunications Standard Institute (ETSI), Rec. ETSI/GSM 04.03, *Mobile Station - Base Station System (MS - BSS) interface Channel structures and access capabilities*, version 3.5.1, March 1992.

# GSM\_DeSdcch8Up



**Description:** 8SDCCH/8 Uplink Disassembly

**Library:** GSM, Framing

**Class:** SDFGSM\_DeSdcch8Up

## Pin Inputs

Pin	Name	Description	Signal Type
1	input	51-frame multiframe of 51*8*156 bits	real

## Pin Outputs

Pin	Name	Description	Signal Type
2	SACCH	SACCH signal	real
3	SDCCH	SDCCH signal	real

## Notes/Equations

- This model is used to disassemble an 8SDCCH/8 uplink 51-frame multiframe as defined in GSM 05.02 standard.  
 $51 \times 8 \times 156$  input tokens are consumed each firing.  
 SACCH:  $16 \times 8 \times 156$  output tokens are produced for each input set of tokens consumed.  
 SDCCH:  $32 \times 8 \times 156$  output tokens are produced for each input set of tokens consumed.
- Implementation  
[8SDCCH/8 Uplink Structure](#) shows structure of 51-frame multiframe 8SDCCH/8 uplink.

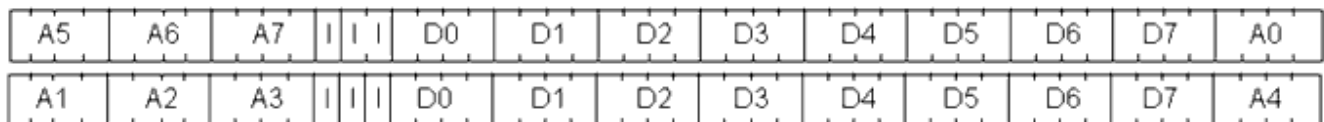

A=SACCH, D=SDCCH  
 |=idle frame

## 8SDCCH/8 Uplink Structure

## References

1. European Telecommunications Standard Institute (ETSI), Rec. ETSI/GSM 05.02, *Multiplexing and Multiple Access on the Radio Path*, version 3.5.1, March 1992.
2. European Telecommunications Standard Institute (ETSI), Rec. ETSI/GSM 03.03, *Numbering, addressing and identification*, version 3.5.1, March 1992.
3. European Telecommunications Standard Institute (ETSI), Rec. ETSI/GSM 04.03, *Mobile Station - Base Station System (MS - BSS) interface Channel structures and access capabilities*, version 3.5.1, March 1992.

# GSM\_DeTDMA

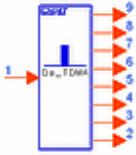

**Description:** TDMA Frame Disassembly

**Library:** GSM, Framing

**Class:** SDFGSM\_DeTDMA

## Pin Inputs

Pin	Name	Description	Signal Type
1	input	one TDMA frame of eight time slots	anytype

## Pin Outputs

Pin	Name	Description	Signal Type
2	O_TN7	data for time slot 7	anytype
3	O_TN6	data for time slot 6	anytype
4	O_TN5	data for time slot 5	anytype
5	O_TN4	data for time slot 4	anytype
6	O_TN3	data for time slot 3	anytype
7	O_TN2	data for time slot 2	anytype
8	O_TN1	data for time slot 1	anytype
9	O_TN0	data for time slot 0	anytype

## Notes/Equations

1. This model is used to disassemble a TDMA frame into 8 time slots as defined in GSM 05.02 standard.
2. Implementation  
In GSM standard, one TDMA frame contains 8 time slots TN0 to TN7. The designer selects a time slot to fill with input data; the idle time slots will be filled with 0. For example, [Time Slot Assignments](#) shows TN2 and TN4 selected, the first 156 input bits of the model will be placed in the third time slot, the second into the fifth, and the others are filled with 0.  
[GSM\\_DeTDMA Subnetwork](#) shows the subnetwork structure, which consists of BusMerge and Commutator.

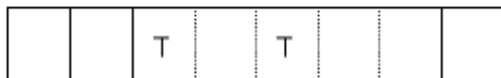

### Time Slot Assignments

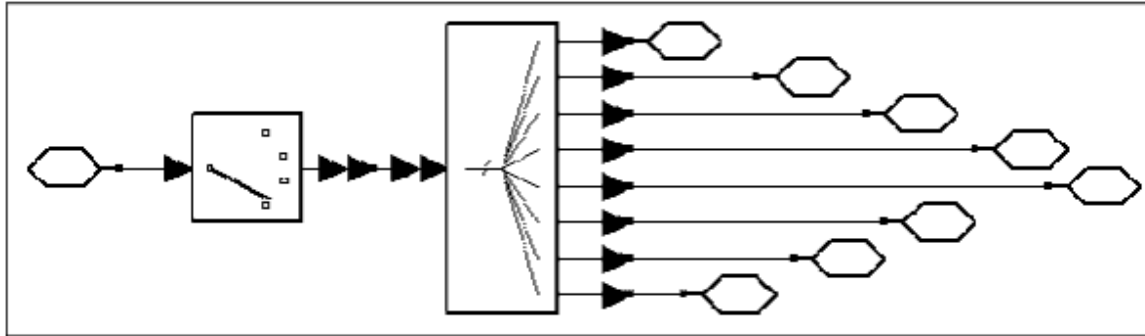

### GSM\_DeTDMA Subnetwork

### References

1. European Telecommunications Standard Institute (ETSI), Rec. ETSI/GSM 05.02, *Multiplexing and Multiple Access on the Radio Path*, version 3.5.1, March 1992.
2. European Telecommunications Standard Institute (ETSI), Rec. ETSI/GSM 03.03, *Numbering, addressing and identification*, version 3.5.1, March 1992.
3. European Telecommunications Standard Institute (ETSI), Rec. ETSI/GSM 04.03, *Mobile Station - Base Station System (MS - BSS) interface Channel structures and access capabilities*, version 3.5.1, March 1992.

# GSM\_DummyBurst



**Description:** Dummy Burst Construction

**Library:** GSM, Framing

**Class:** SDFGSM\_DummyBurst

## Pin Outputs

Pin	Name	Description	Signal Type
1	output	156 modulating bits including 8-bit guarding period	int

## Notes/Equations

1. This model is used to construct dummy burst of 156 bits defined in GSM 05.02 standard.  
156 output tokens are produced.
2. Implementation  
[Dummy Burst Structure](#) shows structure of dummy burst.

TB 3	Mixed Bits 142	TB 3	GP 8.25
---------	-------------------	---------	------------

## Dummy Burst Structure

## References

1. European Telecommunications Standard Institute (ETSI), Rec. ETSI/GSM 05.02, *Multiplexing and Multiple Access on the Radio Path*, version 3.5.1, March 1992.
2. European Telecommunications Standard Institute (ETSI), Rec. ETSI/GSM 03.03, *Numbering, addressing and identification*, version 3.5.1, March 1992.
3. European Telecommunications Standard Institute (ETSI), Rec. ETSI/GSM 04.03, *Mobile Station - Base Station System (MS - BSS) interface Channel structures and access capabilities*, version 3.5.1, March 1992.

# GSM\_FBurst

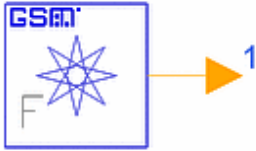

**Description:** Frequency Correction Burst Construction

**Library:** GSM, Framing

**Class:** SDFGSM\_FBurst

## Pin Outputs

Pin	Name	Description	Signal Type
1	output	156 modulating bits including 8-bit guarding period	int

## Notes/Equations

- This model is used to construct frequency correction burst of 156 bits defined in GSM 05.02 standard.  
156 output tokens are produced.
- Implementation  
[Frequency Correction Burst Structure](#) shows the frequency correction burst structure. Bits BN0 to BN2 and BN145 to BN147 are the tail bits; BN3 to BN144 are the fixed zero bits.

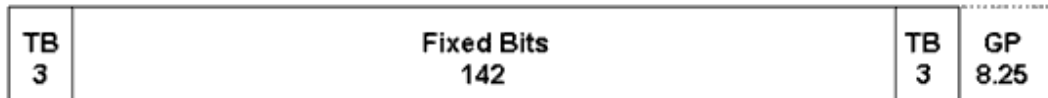

## Frequency Correction Burst Structure

In the TDMA construction, the frequency correction burst must be assigned to time slot 0.

[Frequency Correction Burst](#) shows implementation of the model. After all 156 bits of the burst are arranged, the model outputs the burst as a block. The model consumes and produces data according to the specific bit number indicated in [Frequency Correction Burst](#).

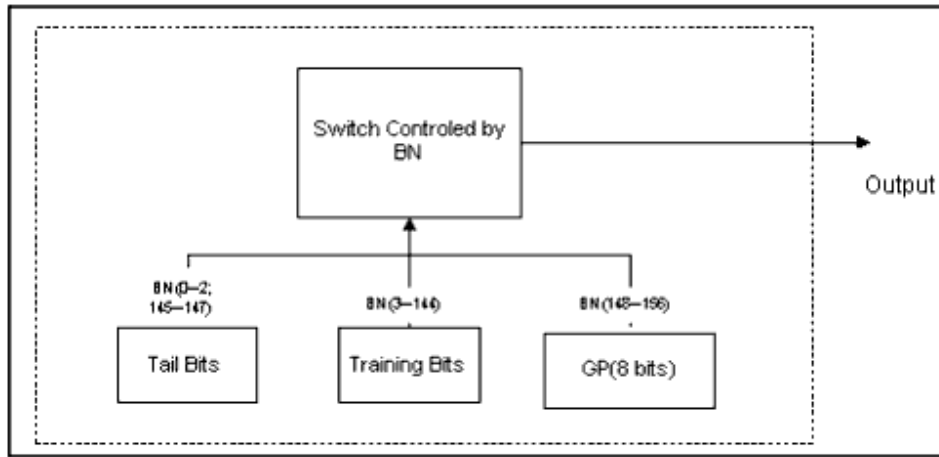

### Frequency Correction Burst

### References

1. European Telecommunications Standard Institute (ETSI), Rec. ETSI/GSM 05.02, *Multiplexing and Multiple Access on the Radio Path*, version 3.5.1, March 1992.
2. European Telecommunications Standard Institute (ETSI), Rec. ETSI/GSM 03.03, *Numbering, addressing and identification*, version 3.5.1, March 1992.
3. European Telecommunications Standard Institute (ETSI), Rec. ETSI/GSM 04.03, *Mobile Station - Base Station System (MS - BSS) interface Channel structures and access capabilities*, version 3.5.1, March 1992.



# GSM\_Multiframe26



**Description:** 26-frame Multiframe Construction

**Library:** GSM, Framing

**Class:** SDFGSM\_Multiframe26

## Pin Inputs

Pin	Name	Description	Signal Type
1	TCH	TCH signal	int
2	SACCH	SACCH signal	int

## Pin Outputs

Pin	Name	Description	Signal Type
3	output	26-frame multiframe	int

## Notes/Equations

- This model is used to construct 26-frame multiframe defined in GSM 05.02 standard.  $26 \times 8 \times 156$  output tokens are produced each firing.  
TCH:  $24 \times 8 \times 156$  input tokens are consumed each firing.  
SACCH:  $8 \times 156$  input tokens are consumed each firing.
- Implementation  
[26-Frame Multiframe Structure](#) shows the 26-multiframe structure. One 26-frame multiframe consists of 26 TDMA frames.

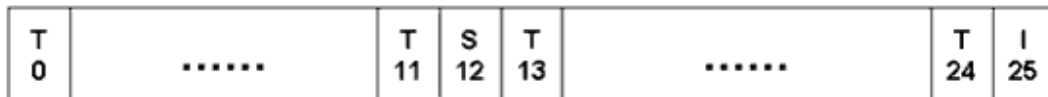

I=idle, S=SACCH, T=TCH

## 26-Frame Multiframe Structure

## References

- European Telecommunications Standard Institute (ETSI), Rec. ETSI/GSM 05.02, *Multiplexing and Multiple Access on the Radio Path*, version 3.5.1, March 1992.
- European Telecommunications Standard Institute (ETSI), Rec. ETSI/GSM 03.03,

*Numbering, addressing and identification*, version 3.5.1, March 1992.

3. European Telecommunications Standard Institute (ETSI), Rec. ETSI/GSM 04.03, *Mobile Station - Base Station System (MS - BSS) interface Channel structures and access capabilities*, version 3.5.1, March 1992.

## GSM\_NormalBurst



**Description:** Normal Burst Construction

**Library:** GSM, Framing

**Class:** SDFGSM\_NormalBurst

### Parameters

Name	Description	Default	Unit	Type	Range
TSC	training sequence code, varies from 0 to 7.	0		int	[0:7]

### Pin Inputs

Pin	Name	Description	Signal Type
1	input	2*58 information bits	int

### Pin Outputs

Pin	Name	Description	Signal Type
2	output	156 modulating bits with 8-bit guarding period	int

### Notes/Equations

- The model is used to construct a normal burst of 156 bits as defined in GSM 05.02 standard.  
156 output tokens are produced for each 2×58 tokens consumed.
- Implementation  
[Normal Burst Structure](#) shows the normal burst structure. Bits BN0 to BN2 and BN145 to BN147 are tail bits; BN3 to BN60 and BN87 to BN144 are encrypted bits that are outputs of channel coding models; BN61 to BN86 are training bits.  
8.25-bit periods must be added to each burst and presented with 0 bit in simulation. Bit representation is not available for the 0.25-bit; the 0.25-bit guarding time period will be added in modulation.

TB 3	Encrypted Bits 58	Training Bits 26	Encrypted Bits 58	TB 3	GP 8.25
---------	----------------------	---------------------	----------------------	---------	------------

### Normal Burst Structure

GSM defines eight different training sequences in normal burst, which are identified by training sequence code value. The following table shows the relation between

training sequence code and training sequence bits.

Training Sequence Code	Training Sequence Bits
0	0,0,1,0,0,1,0,1,1,1,0,0,0,0,1,0,0,0,1,0,0,0,1,0,0,1,0,0,1,0,1,1,1
1	0,0,1,0,1,1,0,1,1,1,0,1,1,1,1,0,0,0,1,0,1,1,0,1,1,0,1,1,1
2	0,1,0,0,0,0,1,1,1,0,1,1,1,0,1,0,0,1,0,0,0,0,1,1,1,0
3	0,1,0,0,0,1,1,1,1,0,1,1,0,1,0,0,0,1,0,0,0,1,1,1,1,0
4	0,0,0,1,1,0,1,0,1,1,1,0,0,1,0,0,0,0,0,1,1,0,1,0,1,1
5	0,1,0,0,1,1,1,0,1,0,1,1,0,0,0,0,0,1,0,0,1,1,1,0,1,0
6	1,0,1,0,0,1,1,1,1,1,0,1,1,0,0,0,1,0,1,0,0,1,1,1,1,1
7	1,1,1,0,1,1,1,1,0,0,0,1,0,0,1,0,1,1,1,0,1,1,1,1,0,0

## References

1. European Telecommunications Standard Institute (ETSI), Rec. ETSI/GSM 05.02, *Multiplexing and Multiple Access on the Radio Path*, version 3.5.1, March 1992.
2. European Telecommunications Standard Institute (ETSI), Rec. ETSI/GSM 03.03, *Numbering, addressing and identification*, version 3.5.1, March 1992.
3. GSM Recommendation 04.03, *Mobile Station - Base Station System (MS - BSS) interface Channel structures and access capabilities*, version 3.5.1, March 1992.

# GSM\_SBurst



**Description:** Synchronization Burst Construction

**Library:** GSM, Framing

**Class:** SDFGSM\_SBurst

## Pin Inputs

Pin	Name	Description	Signal Type
1	input	2*39 encrypted bits	int

## Pin Outputs

Pin	Name	Description	Signal Type
2	output	156 modulating bits including 8-bit guarding period	int

## Notes/Equations

1. The model is used to construct synchronization burst of 156 bits defined in GSM 05.02 standard.  
156 output tokens are produced for each 2×39 tokens consumed.

2. Implementation

[Synchronization Burst Structure](#) shows the synchronization burst structure.

TB 3	Encrypted Bits 39	Extended Training Bits 64	Encrypted Bits 39	TB 3	GP 8.25
---------	----------------------	------------------------------	----------------------	---------	------------

## Synchronization Burst Structure

In the TDMA construction, the frequency correction burst must be assigned to time slot 0.

The extended training bits are defined as

(BN42, BN43, ... , BN105)=

(1,0,1,1,1,0,0,1,0,1,  
1,0,0,0,1,0,0,0,0,0,  
0,1,0,0,0,0,0,0,1,1,  
1,1,0,0,1,0,1,1,0,1,  
0,1,0,0,0,1,0,1,0,1,1,  
1,0,1,1,0,0,0,0,1,1,0,1,1)

## References

1. European Telecommunications Standard Institute (ETSI), Rec. ETSI/GSM 05.02, *Multiplexing and Multiple Access on the Radio Path*, version 3.5.1, March 1992.
2. European Telecommunications Standard Institute (ETSI), Rec. ETSI/GSM 03.03, *Numbering, addressing and identification*, version 3.5.1, March 1992.
3. European Telecommunications Standard Institute (ETSI), Rec. ETSI/GSM 04.03, *Mobile Station - Base Station System (MS - BSS) interface Channel structures and access capabilities*, version 3.5.1, March 1992.

# GSM\_Sdcch8Dn



**Description:** 8SDCCH/8 Downlink Construction

**Library:** GSM, Framing

**Class:** SDFGSM\_Sdcch8Dn

## Pin Inputs

Pin	Name	Description	Signal Type
1	SACCH	SACCH signal	int
2	SDCCH	SDCCH signal	int

## Pin Outputs

Pin	Name	Description	Signal Type
3	output	51-frame multiframe of SDCCH downlink	int

## Notes/Equations

- This model is used to construct an 8SDCCH/8 downlink 51-frame multiframe as defined in GSM 05.02 standard.  
 $51 \times 8 \times 156$  output tokens are produced for each input set of tokens consumed.  
 SACCH:  $16 \times 8 \times 156$  input tokens are consumed each firing.  
 SDCCH:  $32 \times 8 \times 156$  input tokens are consumed each firing.
- Implementation  
[8SDCCH/8 Downlink Structure](#) shows the 51-frame multiframe structure. One 51-frame multiframe consists of 51 TDMA frames. The expression SDCCH/8+SACCH/8 indicates that eight different SDCCHs can be used with eight SACCH resources in this combination, and thus may serve for eight parallel signaling links on one physical channel.

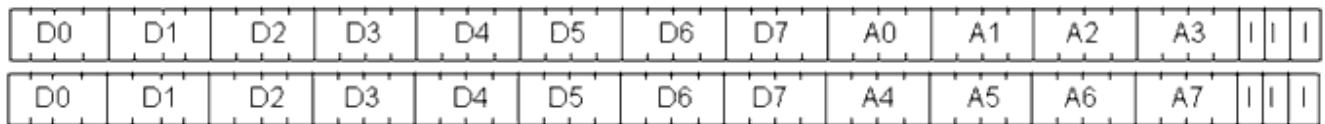

A=SACCH, D=SDCCH  
 I=idle frame

## 8SDCCH/8 Downlink Structure

## References

1. European Telecommunications Standard Institute (ETSI), Rec. ETSI/GSM 05.02, *Multiplexing and Multiple Access on the Radio Path*, version 3.5.1, March 1992.
2. European Telecommunications Standard Institute (ETSI), Rec. ETSI/GSM 03.03, *Numbering, addressing and identification*, version 3.5.1, March 1992.
3. European Telecommunications Standard Institute (ETSI), Rec. ETSI/GSM 04.03, *Mobile Station - Base Station System (MS - BSS) interface Channel structures and access capabilities*, version 3.5.1, March 1992.



# GSM\_Sdcch8Up



**Description:** 8SDCCH/8 Uplink Construction

**Library:** GSM, Framing

**Class:** SDFGSM\_Sdcch8Up

## Pin Inputs

Pin	Name	Description	Signal Type
1	SACCH	SACCH signal	int
2	SDCCH	SDCCH signal	int

## Pin Outputs

Pin	Name	Description	Signal Type
3	output	51-frame multiframe of SDCCH uplink	int

## Notes/Equations

1. This model is used to construct an 8SDCCH/8 uplink 51-frame multiframe as defined in GSM 05.02 standard.

51×8×156 output tokens are produced for each input set of tokens consumed.

SACCH: 16×8×156 input tokens are consumed each firing.

SDCCH: 32×8×156 input tokens are consumed each firing.

2. Implementation

[8SDCCH/8 Uplink Structure](#) shows structure of 51-frame multiframe 8SDCCH/8 uplink.

[8SDCCH/8 Uplink Construction](#) shows the implementation of the model. The model consumes and produces data according to the specific frame number indicated.

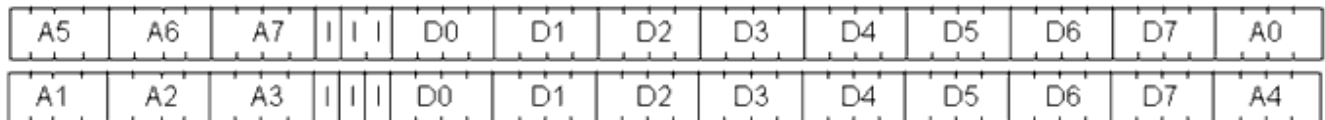

A=SACCH, D=SDCCH

|=idle frame

## 8SDCCH/8 Uplink Structure

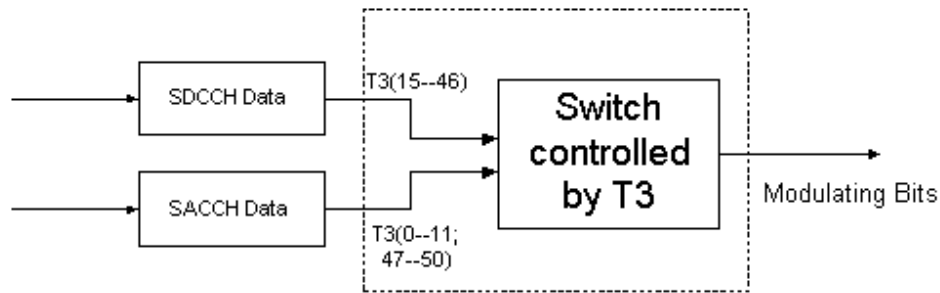

### 8SDCCH/8 Uplink Construction

### References

1. European Telecommunications Standard Institute (ETSI), Rec. ETSI/GSM 05.02, *Multiplexing and Multiple Access on the Radio Path*, version 3.5.1, March 1992.
2. European Telecommunications Standard Institute (ETSI), Rec. ETSI/GSM 03.03, *Numbering, addressing and identification*, version 3.5.1, March 1992.
3. European Telecommunications Standard Institute (ETSI), Rec. ETSI/GSM 04.03, *Mobile Station - Base Station System (MS - BSS) interface Channel structures and access capabilities*, version 3.5.1, March 1992.

# GSM\_TDMA

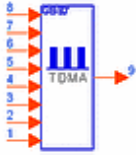

**Description:** TDMA Frame Construction

**Library:** GSM, Framing

**Class:** SDFGSM\_TDMA

## Pin Inputs

Pin	Name	Description	Signal Type
1	TN7	data for time slot 7	anytype
2	TN6	data for time slot 6	anytype
3	TN5	data for time slot 5	anytype
4	TN4	data for time slot 4	anytype
5	TN3	data for time slot 3	anytype
6	TN2	data for time slot 2	anytype
7	TN1	data for time slot 1	anytype
8	TN0	data for time slot 0	anytype

## Pin Outputs

Pin	Name	Description	Signal Type
9	output	one TDMA frame of consist of 8 time slots	anytype

## Notes/Equations

1. This subnetwork is used to construct one TDMA frame as defined in GSM 05.02 standard.
2. Implementation  
 In GSM standard, one TDMA frame contains eight time slots TN0 to TN7. The designer selects which time slots to fill with input data; the idle time slots will be filled with 0. [Time Slot Assignments](#) shows TN2 and TN4 are selected, the first 156 input bits of the subnetwork will be placed in the third time slot, the second into the fifth, the rest will be filled with 0.  
[GSM\\_TDMA Subnetwork](#) shows the structure of the subnetwork; it consists of Busmerge and Commutator.

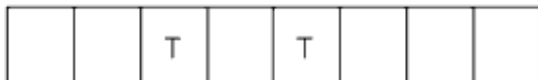

### Time Slot Assignments

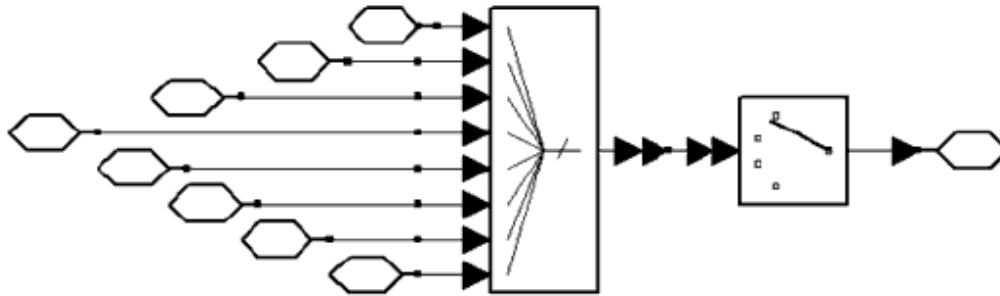

### GSM\_TDMA Subnetwork

### References

1. European Telecommunications Standard Institute (ETSI), Rec. ETSI/GSM 05.02, *Multiplexing and Multiple Access on the Radio Path*, version 3.5.1, March 1992.
2. European Telecommunications Standard Institute (ETSI), Rec. ETSI/GSM 03.03, *Numbering, addressing and identification*, version 3.5.1, March 1992.
3. European Telecommunications Standard Institute (ETSI), Rec. ETSI/GSM 04.03, *Mobile Station - Base Station System (MS - BSS) interface Channel structures and access capabilities*, version 3.5.1, March 1992.

# GSM\_TimeBaseCounter



**Description:** Time Base Counter for T1, T2, T3

**Library:** GSM, Framing

**Class:** SDFGSM\_TimeBaseCounter

## Pin Inputs

Pin	Name	Description	Signal Type
1	input	modulating data	int

## Pin Outputs

Pin	Name	Description	Signal Type
2	T1	counter for superframes	int
3	T2	counter for frames in 26-frame multiframe structure	int
4	T3	counter for frames in 51-frame multiframe structure	int

## Notes/Equations

- This model is used to perform as GSM timebase counters for counting T1, T2, and T3 as defined in GSM 05.02 standard. One token of T1, T2, and T3 are produced for each  $8 \times 156$  input tokens consumed.
- Implementation
 

When describing the signaling frame structure, it is important to know which frame is currently being transmitted. To remove the possibility of ambiguity: T1 counts the superframes; T2 counts frames in 26-frame multiframe structures; T3 counts the signaling frames, which are 51-frame multiframe structures (T3 ranges from 0 to 50).

At starting time, the counters are set to 0, and the frames begin to be transmitted. When a speech or signaling multiframe structure is finished, its respective counters (T2 or T3) are reset to 0 and start again.

After 1326 TDMA frames, T2 and T3 are reset and start counting again from 0. This marks the duration of one superframe. When the first superframe is completed, T1 increments by 1. T1 only resets after 2047, which takes more than 3 hours to do so, and this is the duration of a hyperframe.

## References

- European Telecommunications Standard Institute (ETSI), Rec. ETSI/GSM 05.02,

*Multiplexing and Multiple Access on the Radio Path*, version 3.5.1, March 1992.

2. European Telecommunications Standard Institute (ETSI), Rec. ETSI/GSM 03.03, *Numbering, addressing and identification*, version 3.5.1, March 1992.
3. European Telecommunications Standard Institute (ETSI), Rec. ETSI/GSM 04.03, *Mobile Station - Base Station System (MS - BSS) interface Channel structures and access capabilities*, version 3.5.1, March 1992.

# GSM Design Examples

These design examples are provided in the **/examples/gsm** directory.

# Error Distribution Analysis of Adaptive Equalizer in Normal Burst

## EquErrPattern\_wrk Design Name

- GSM\_BurstErrorPattern

## Features

- Displays error distribution in GSM normal burst
- Fading channel with additive white Gaussian noise
- Adaptive equalizer uses maximum-likelihood sequence estimation
- Tcl/Tk plot for interactive display

## Description

This example demonstrates an error pattern analysis throughout a normal burst to show the adaptive equalizer performance. In transmission, a random bit source component is used as channel coded data source. The data and training sequence are used in constructing a normal burst. After GMSK modulation, the signal is transmitted through a fading GSM channel, and additive Gaussian noise is added to the received signal. A downsample component is used instead of a normal burst bit synchronization component. The adaptive equalizer implements demodulation of the signal output from the receiver (Butterworth) filter. The bit error rate of each position in normal burst is statistically calculated by an error pattern display component and output to an interactive plot component for display.

In the adaptive equalizer, maximum-likelihood sequence estimation is used to implement demodulation. The bits in the middle of normal burst have the lowest BER because the training sequence in the middle of normal burst is used to estimate the channel characteristic using maximum-likelihood sequence estimation. The BER is increased from the center of normal burst to the both ends, which means that the performance of equalizer is greatly affected by channel estimation accuracy.

## Schematics

[GSM\\_BurstErrorPattern](#) shows the schematic for this design. [GSM\\_ReceiverSubnetwork](#) shows the adaptive equalizer subnetwork.



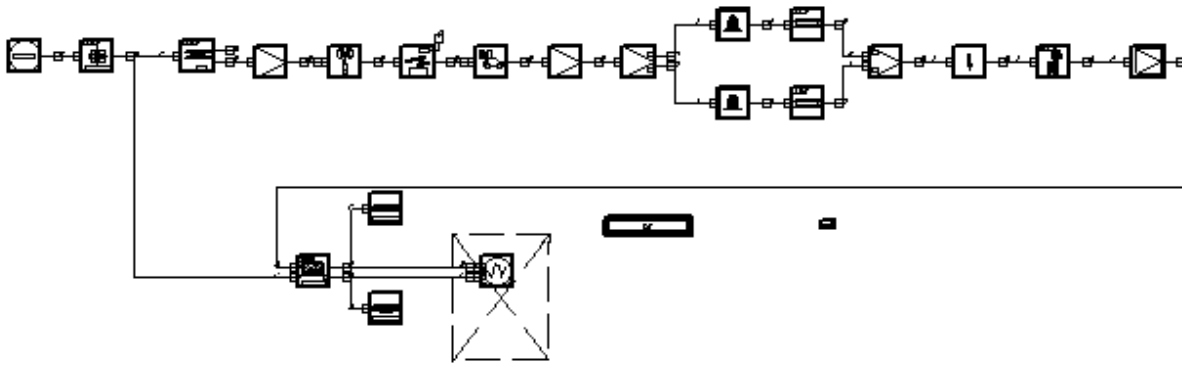

**GSM\_BurstErrorPattern**

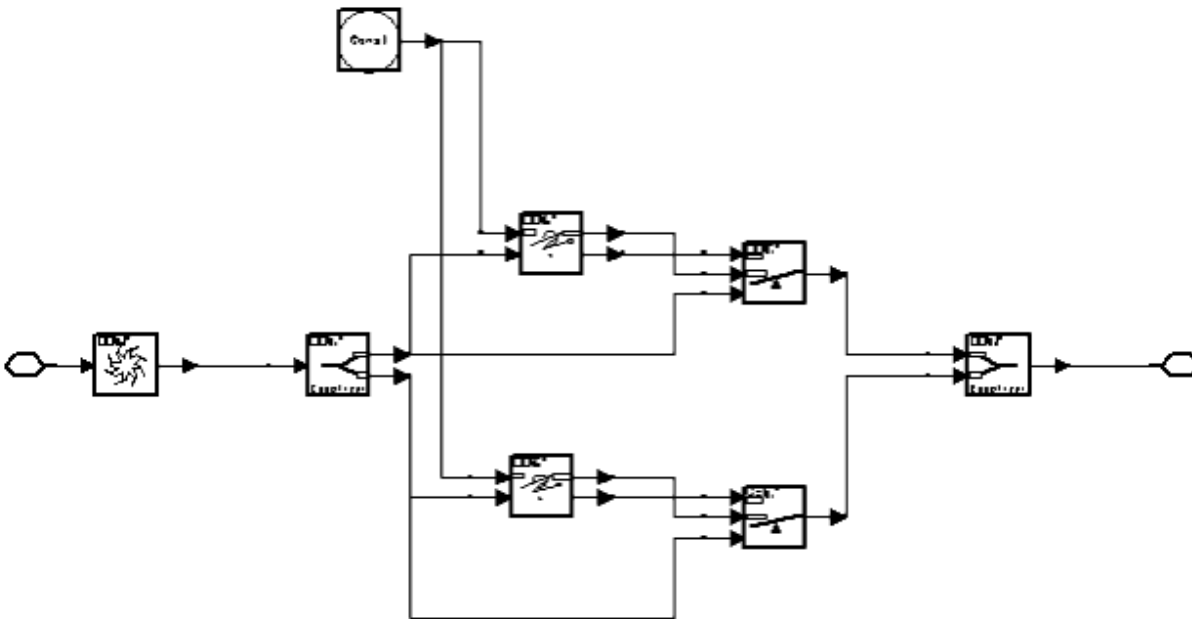

**GSM\_Receiver Subnetwork**

**Specifications**

Symbol	Specification	Simulation Type	Value	Unit
Pc	power per bit	ADS Ptolemy	1.0	W
M	GMSK modulation sample rate	ADS Ptolemy	1	N/A
TSC	training sequence code	ADS Ptolemy	0	N/A
TStep	output time step for channel model	ADS Ptolemy	3.692/8	μ sec

**Notes**

- Sample Rate is 4, 8, or 16 when M is 0, 1 or 2, respectively.
- TStep must be related to M, that is SampleRate=8 and TStep=3.69/SampleRate  $\mu$ sec.

## Simulation Results

The results, shown in [Error Pattern throughout Normal Burst](#), are obtained with a TU50 channel, no frequency offset, and SNR is 7.6 dB.

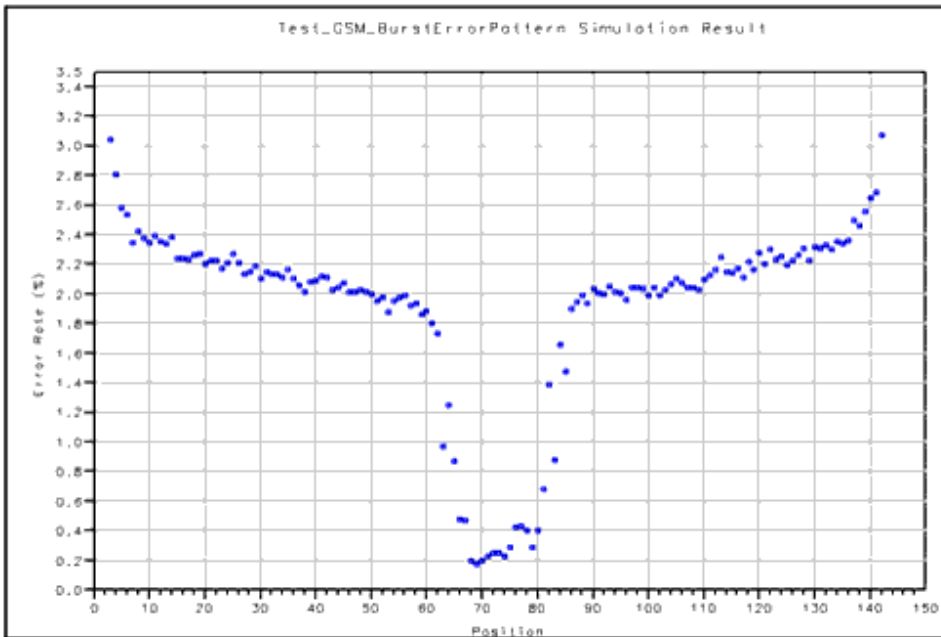

## Error Pattern throughout Normal Burst

## Benchmark

- Hardware Platform: Pentium Pro 200 MHz, 96 MB memory
- Software Platform: Windows NT 4.0 Workstation, Advanced Design System 1.1
- Data Points: 100000 frames
- Simulation Time: approximately 16 hours

# Fast Associated Control Channel

## FACCHsys\_wrk Design Name

- GSM\_SysFACCH

## Features

- GSM propagation fading channel and additive white Gaussian noise
- Fast associated control channel
- Channel interleaving and de-interleaving
- GMSK modulator and maximum-likelihood sequence estimation equalizer
- Gaussian noise with adjustable noise variance
- BER and FER performance stored in NumericSink

## Description

This example shows the system performance of BER and FER on fast associated control channel. It consists of error correction encoding and decoding, interleaving and de-interleaving, data framing and deframing, GMSK modulation, GSM fading channel plus AWGN, 7-order Butterworth filter, bit synchronization and maximum-likelihood sequence estimation receiver.

In fast associated control channel, a Fire code with tail bits, a convolutional code and block diagonal interleaver are used. Each 184 data bits are transformed into 456 bits after channel coding and interleaving.

For details about framing, GMSK modulation, synchronization and MLSE reception, refer to *Traffic Channel for Data Transmission at 9.6 kbps*.

## Schematics

[GSM\\_SysFACCH](#) shows the schematic for this design. Data source is a random bit sequence (B1).

[GSM\\_FACCH\\_Encoder\\_Subnetwork](#) shows the GSM\_FACCH\_Encoder subnetwork used in [GSM\\_SysFACCH](#) (detailed implementation of channel coding and interleaving for fast associated control channel). The number of input and output bits of cyclic encoder are 184 and 224, respectively. Four tail bits are added to the cyclic coded data. These 228 bits are convolutionally encoded to 456 bits with constraint length of 5 and rate of 1/2. GSM\_Interleaver\_8 is used to interleave the input 456 bits into eight blocks.

[GSM\\_FACCH\\_Decoder\\_Subnetwork](#) shows GSM\_FACCH\_Decoder subnetwork.

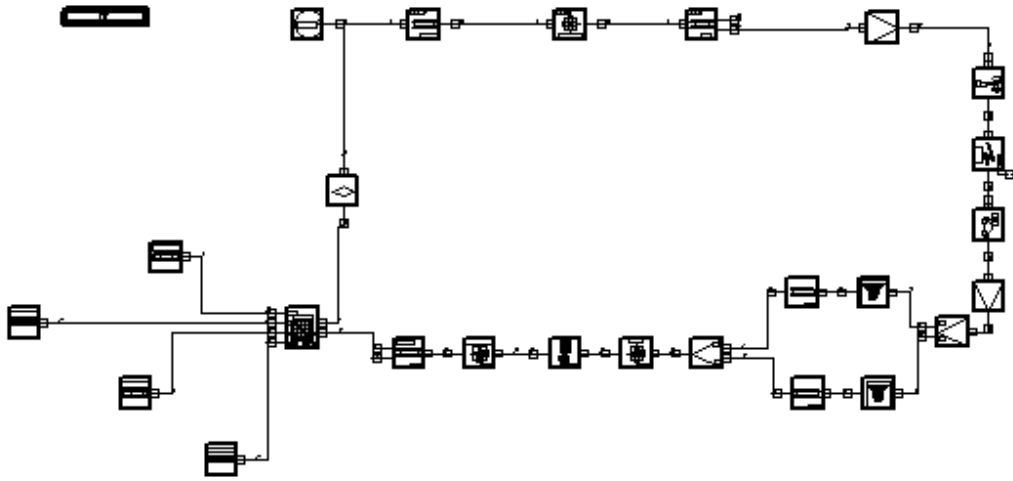

### GSM\_SysFACCH

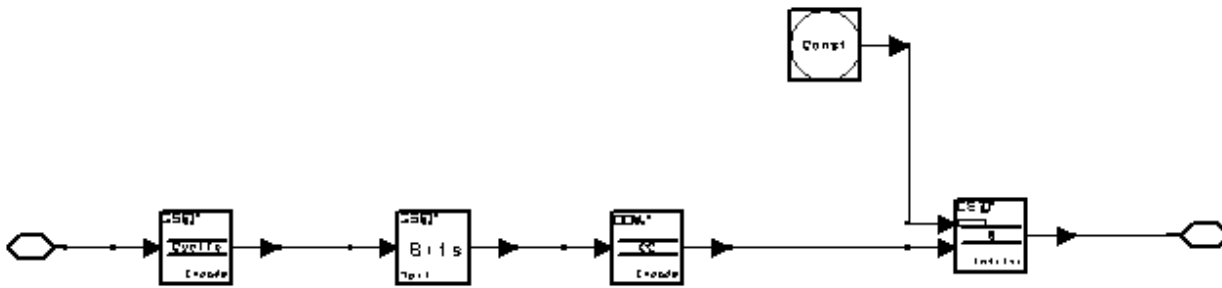

### GSM\_FACCH\_Encoder Subnetwork

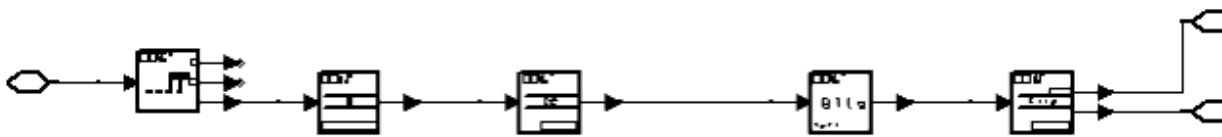

### GSM\_FACCH\_Decoder Subnetwork

## Specifications

Symbol	Specification	Simulation Type	Value	Unit
GlobalPc	power per bit	ADS Ptolemy	1e-3	W
FCarrier	carrier frequency	ADS Ptolemy	900	MHz
SR	sample rate	ADS Ptolemy	8	N/A
TStep	output time step for channel model	ADS Ptolemy	3.692/8	μsec

### Notes

- TStep must be related to SR, that is  $TStep = 3.69/SR$  μsec.
- The input of the system is delayed by 184 bits before the BER, FER measurement.

### Simulation Results

[BER and FER](#) shows bit error and BER and frame error and FER.

### Test Conditions

- Channel Type: TU50 (urban area, 50 km/hr)
- SNR: 16.9 dB
- FER test results: 0.48%
- Recommended (GSM Specification 05.05) FER: 8%

### Benchmark

- Hardware Platform: Pentium Pro 200 MHz, 96 MB memory
- Software Platform: Windows NT 4.0 Workstation, Advanced Design System 1.1
- Data Points: 10000 frames
- Simulation Time: approximately 16 hours

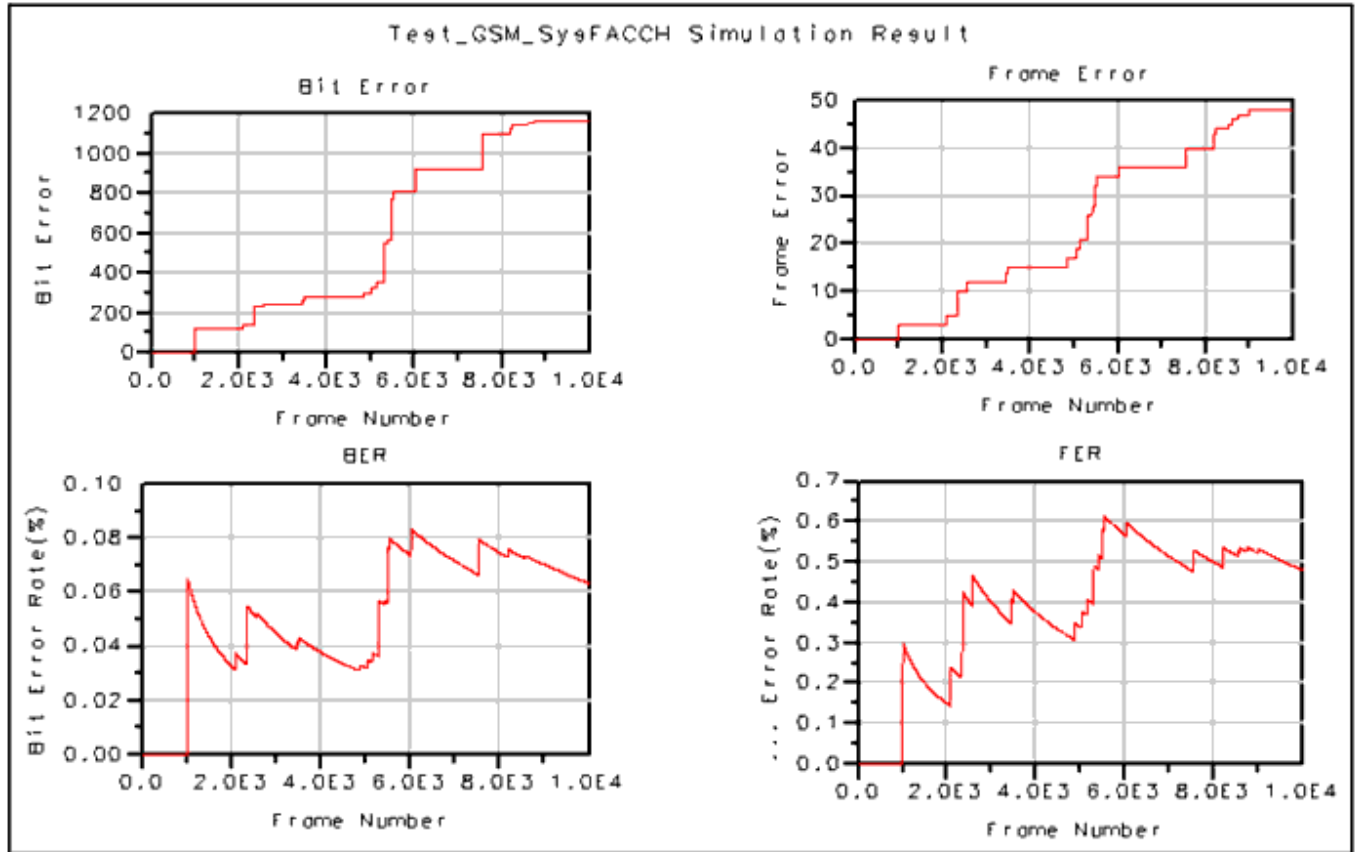

**BER and FER**

# GMSK Modulation Spectrum

## GMSKModSpec\_wrk Design Name

- GSM\_GMSKModSpectrum

## Features

- GMSK modulation complying with GSM specification
- Adjustable sample rate
- Displays spectrum analysis
- Integrated RF section

## Description

This example shows GMSK modulation ( $BT_b=0.3$ ,  $B$  is 3 db bandwidth for Gaussian filter,  $T_b$  is bit time) and performs spectrum analysis. The GMSK modulation model is used to generate GMSK modulated signal, which is represented by complex envelope equivalent and carrier frequency; it also performs differential encoding.

GMSK modulation is recommended for GSM systems with  $BT_b=0.3$  and rate 270.833 kbits/s. GMSK is a type of constant-envelope FSK, where frequency modulation is a result of carefully planned phase modulation. The frequency shifting in GMSK comes from carefully steering the phase of the carrier in quadrature so as to yield a continuous phase transition. The most important feature of GMSK is that it is a constant-envelope variety of modulation. This means there is a distinct lack of AM in the carrier with a consequent limiting of the occupied bandwidth. The constant amplitude of the GMSK signal makes it suitable for use with high-efficiency amplifiers.

The GSM\_GMSKMod subnetwork receives the bit stream and produces modulated signal  $xg(t)$ . Instead of generating  $xg(t)$  directly, we use complex envelope equivalent of  $xg(t)$  and carrier frequency  $f_c$  to represent it. This sub-network is composed of GSM\_DifferEncoder, GSM\_Rom and GSM\_Carrier. After baseband modulation, the signal is fed to the RF section, which consists of RF mixer, Butterworth filter, and RF gains.

## Schematics

[GSM\\_GMSKModSpectrum](#) shows the schematic for this design. The schematic contains Bit source, GSM\_GMSKMod, CxToTimed, RF section, a spectrum analyzer, and a timed sink. The source of GMSK modulation can be any 0 or 1 signal. GMSK modulation complies with GSM specification. CxToTimed transfers the SDF signal to TSDF signal so that the spectrum analyzer model can perform spectrum analysis.

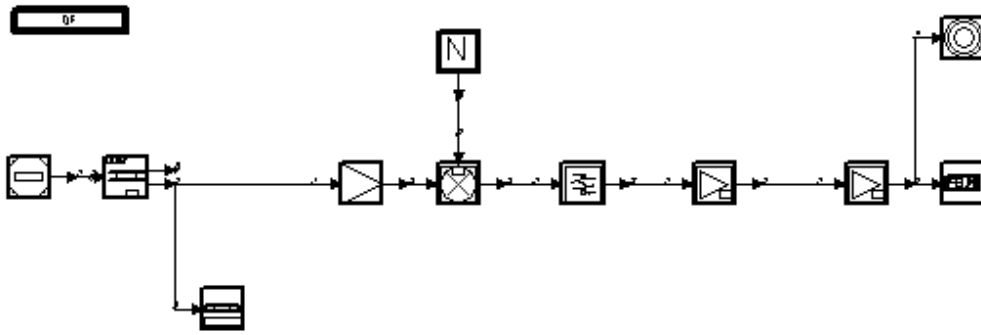

### GSM\_GMSKModSpectrum

[GSM\\_GMSKMod Subnetwork](#) is the GSM\_GMSKMod subnetwork used in [GSM\\_GMSKModSpectrum](#). The subnetwork includes:

- GSM\_DifferEncoder to implement differential encoding of the input bits which is required in GSM specification to generate GMSK signal. According to the specification GSM 05.04, the initial value of the first bit is assigned to 1. After the differential coding, the model maps 0 to 1, 1 to -1.
- GSM\_Rom to generate the modulated signal of I, Q branches.
- GSM\_Carrier to generate the modulated signal, which is represented by complex envelope equivalent and carrier frequency.

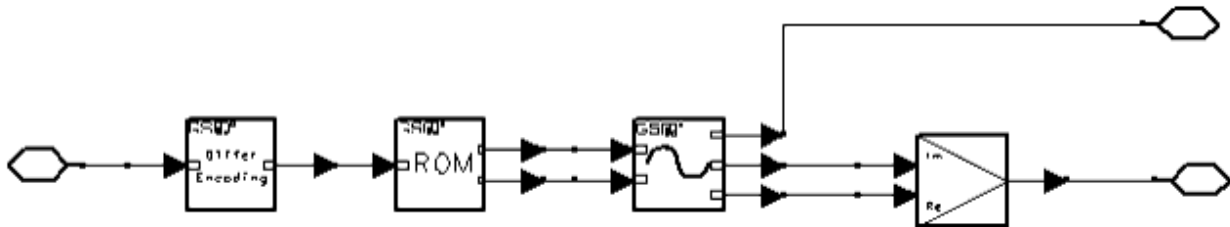

### GSM\_GMSKMod Subnetwork

#### Specifications

Symbol	Specification	Simulation Type	Value	Unit
M	number of samples in one bit interval	ADS Ptolemy	SampleRate16	N/A
TStep	output time step	ADS Ptolemy	3.69/16	µsec
Window	spectrum window type	ADS Ptolemy	Flat_Top	N/A
RF frequency	RF central frequency	ADS Ptolemy	935.2	MHz

#### Notes

- TStep must be related to M, that is  $TStep = 3.69 / \text{Samplerate} \mu\text{sec}$ .



## Simulation Results

[Magnitude, Phase and Spectrum for 0.3 GMSK Modulated Random Signal](#) shows the magnitude, phase and spectrum of the GMSK modulated data. The central frequency is 935.2 MHz.

[Spectrum of the 0.3GMSK Modulated All-Zero Signal](#) shows the spectrum of the modulated signal when inputs are all zero. We can see that the center frequency is 67.7 kHz up shift from the center frequency 935.2 MHz, which is consistent with the GSM specification.

## Benchmark

- Hardware platform: Pentium Pro 200 MHz, 96 MB memory
- Software platform: Windows NT 4.0 Workstation, Advanced Design System 1.1
- Data points: 6000 frames
- Simulation time: approximately 30 seconds

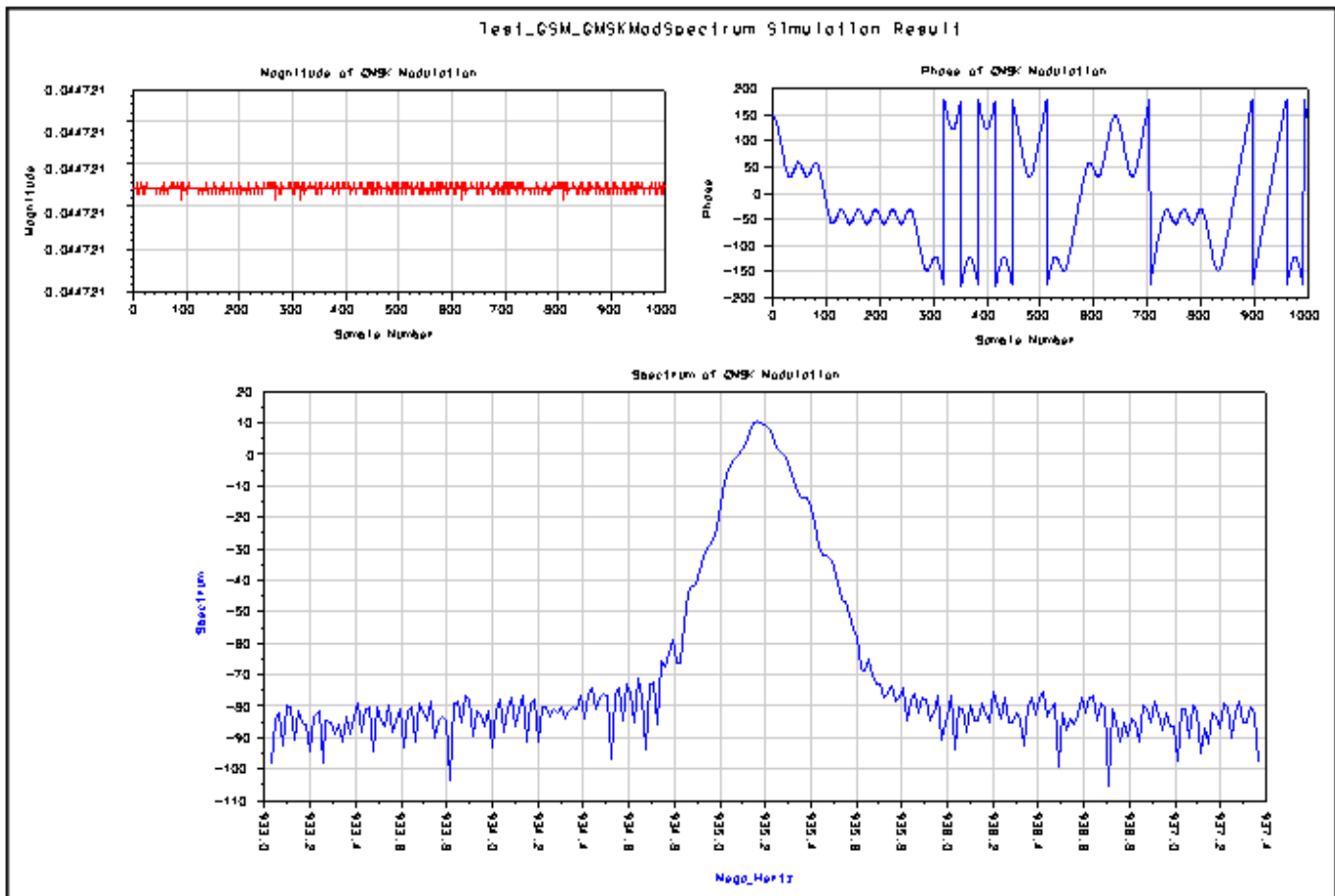

Magnitude, Phase and Spectrum for 0.3 GMSK Modulated Random Signal

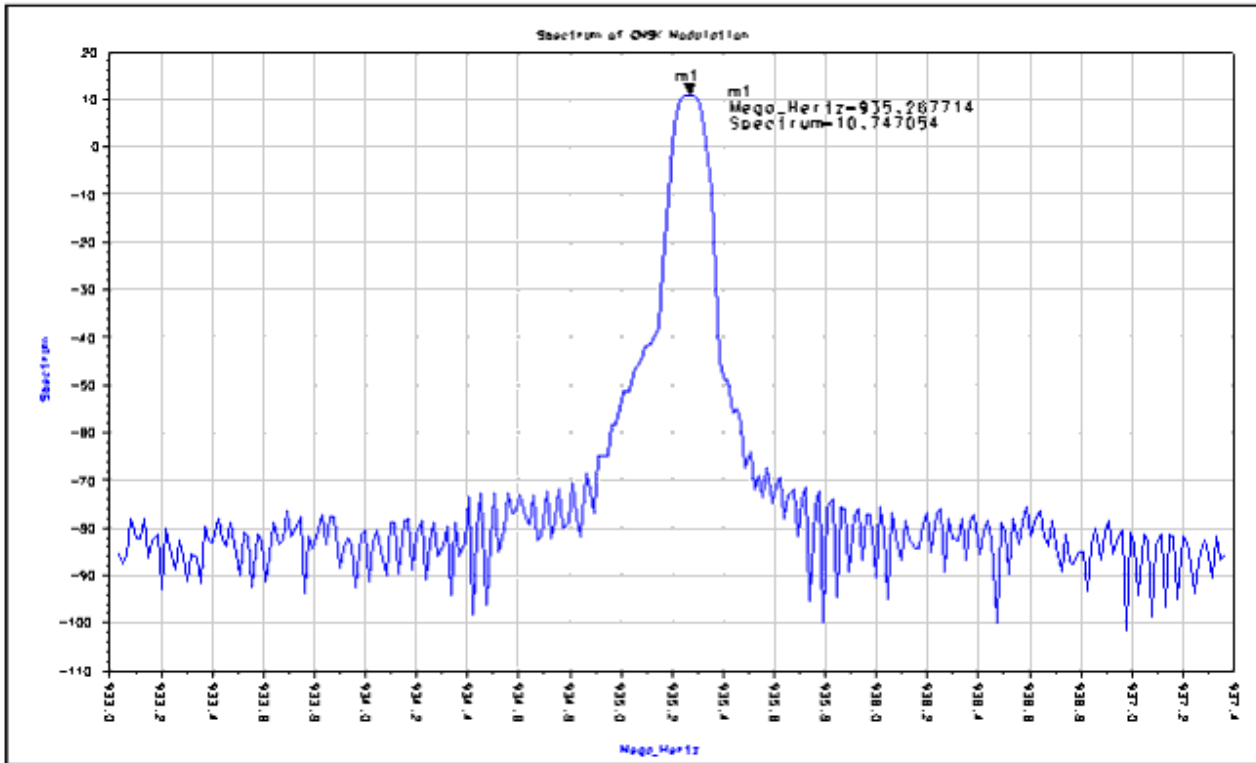

Spectrum of the 0.3GMSK Modulated All-Zero Signal

# GSM Speech Codec

## GSM\_SpeechCodec\_wrk Design Names

- GSM\_SpeechCodec

## Features

- GSM Speech Coding library implemented by RPE-LTP
- Numeric Sinks used for output display
- User-selectable input and output voice file
- Output speech waveforms compared with input waveform

## Description

This example demonstrates GSM Speech Codec based on the algorithm described in GSM specification 06.10, called regular pulse excitation-long term prediction-linear predictive coder (RPE-LTP). In this example, all components provided in GSM Speech Codec library are used. First, a speech stream, at 128 kbit/sec, is read from the *PCM.wav* file by `GSM_ReadFile` and displayed as reference. Through subnetwork `GSM_SpeechEncoder`, the signal is converted to a bit stream at rate of 13 kbit/sec. After decoding, the recovered speech is displayed for comparison. Only mono channel Windows *wav* file with 8 kHz sample rate, 16 bits per sample is supported.

## Schematics

[GSM\\_SpeechCodec](#) shows the schematic for this design.

[GSM\\_SpeechEncoder Subnetwork](#) shows the `GSM_SpeechEncoder` subnetwork used in [GSM\\_SpeechCodec](#).

[GSM\\_SpeechDecoder Subnetwork](#) shows the `GSM_SpeechDecoder` subnetwork used in [GSM\\_SpeechCodec](#).

0

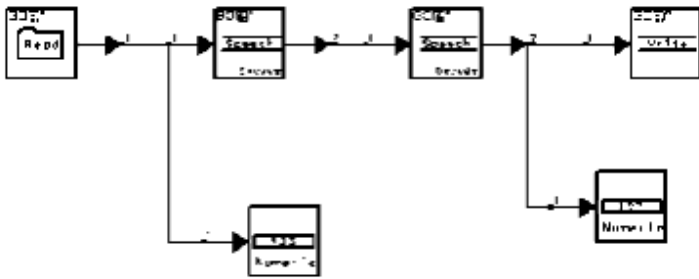

### GSM\_SpeechCodec

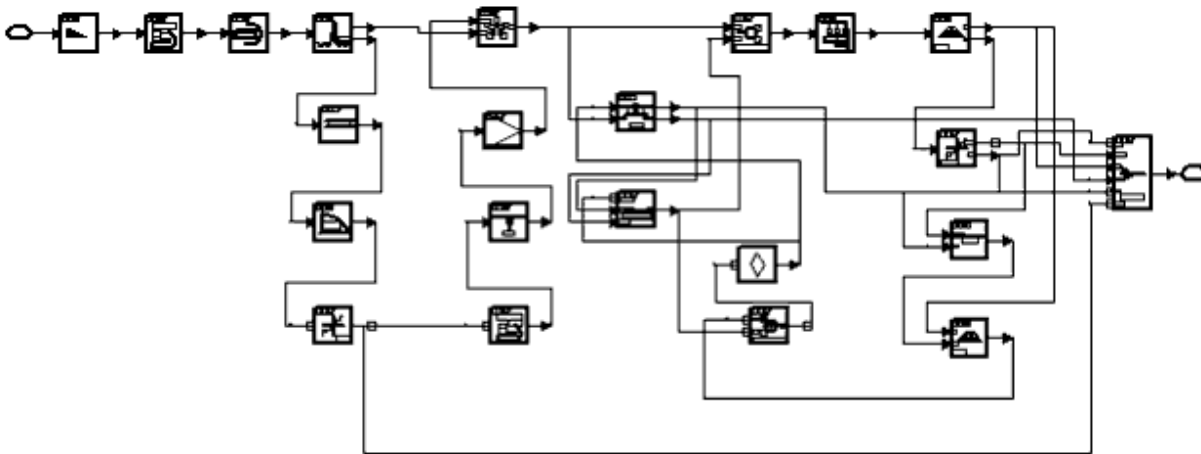

### GSM\_SpeechEncoder Subnetwork

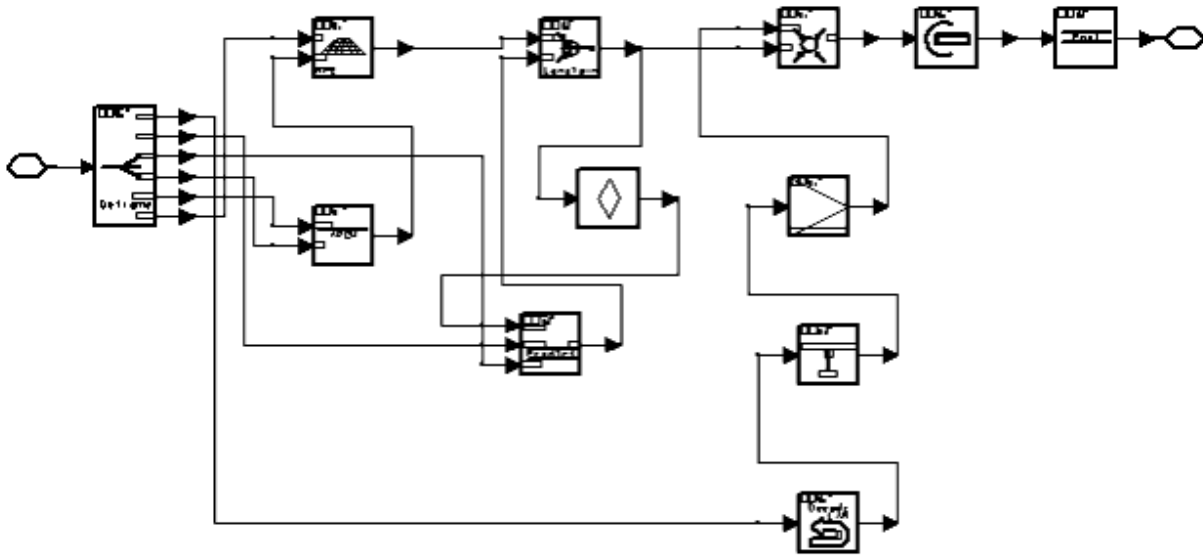

### GSM\_SpeechDecoder Subnetwork

### Specifications

Specification	Simulation Type	Value	Unit
input sample rate	ADS Ptolemy	8	kHz
input bit rate	ADS Ptolemy	128	kbps
output sample rate	ADS Ptolemy	8	kHz
output bit rate	ADS Ptolemy	13	kbps

### Notes

- Parameters in GSM\_SpeechDecoder such as FrameSize and SubFrameSize must be consistent with GSM\_SpeechEncoder.
- The default path for input and output file is the data directory under the current workspace. The path and file name is user-settable.

### Simulation Results

[Comparison of Input and Output Speech Waveforms](#) shows that the waveform of the recovered signal is close to the input signal.

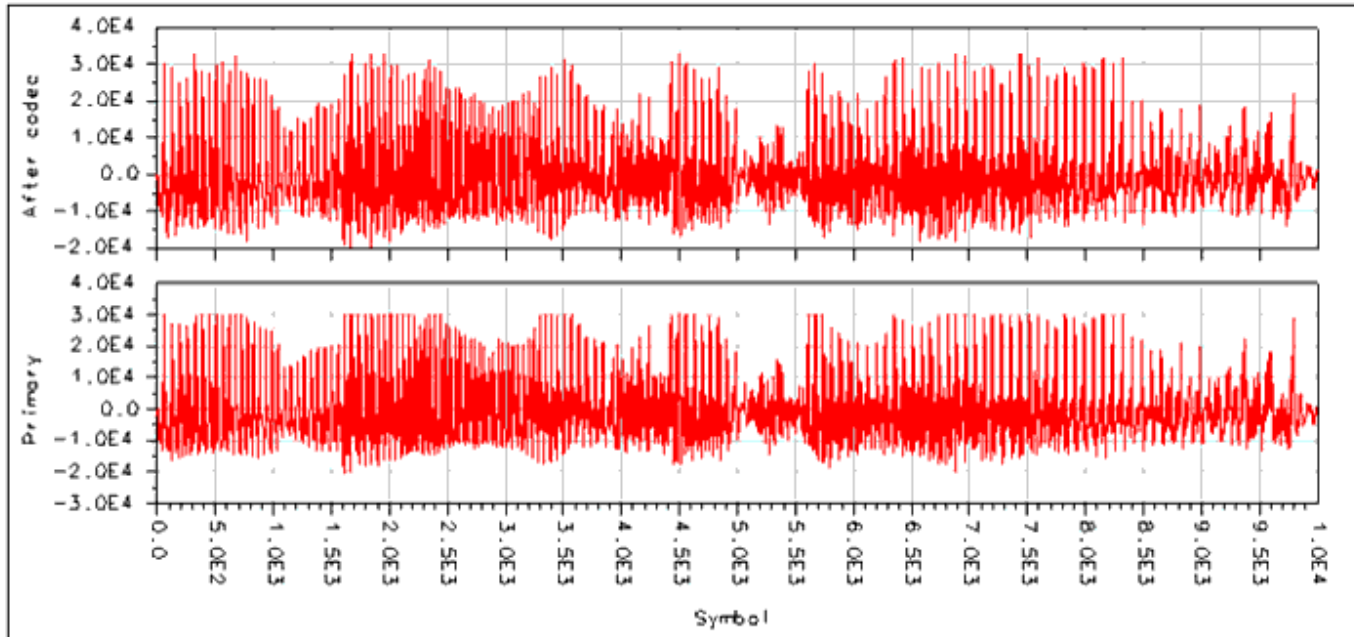

#### Comparison of Input and Output Speech Waveforms

#### Benchmark

- Hardware platform: Pentium Pro 200 MHz, 96 MB memory
- Software platform: Windows NT 4.0 Workstation, Advanced Design System 1.1
- Data points: 10000 points
- Simulation time: approximately 2 minutes

# GSM Traffic Channel Full Rate Speech Measurement

## Measurement\_TCH\_wrk Design Names

- GSM\_Measurement\_TCH

## Features

- One TDMA frame with all time slots assigned to TCH/FS
- Normal burst construction
- Channel codec for TCH/FS
- Gaussian minimum shift keying (GMSK,  $BT=0.3$ , B is 3 dB bandwidth for Gaussian filter, T is bit time) modulation
- Radio frequency with 935.2 MHz in GSM band
- GMSK spectrum
- GMSK IQ constellations, eye diagram, phase trajectory and adjacent channel power ratio

## Description

This example generates one TDMA frame signal for transmission at 270.8333 kbit/sec bit rate GMSK modulation for GSM measurement. It includes one TDMA frame of eight time slots at carrier frequency of 935.2 MHz. The Training Sequence Code (TSC) value is set to 0.

The source of the system is a random bit source. Input data is convolutionally coded, with constraint length of 5 and rate 1/2, and interleaved before it is fed into a normal burst component. After the training sequence, tail bits and guard time bits are added by the normal burst construction component; eight normal bursts are combined into one TDMA frame; this frame is placed in the GMSK modulation model.

Then the baseband signal is fed into the RF section that includes mixer, Butterworth filter and RF gain. The timed sink and spectrum analyzer is used to store the signal and GMSK spectrum.

The ACPR measurement can be displayed by opening the *ACPR.dds* file.

[GSM\\_Measurement\\_TCH](#) shows the schematic for this design.

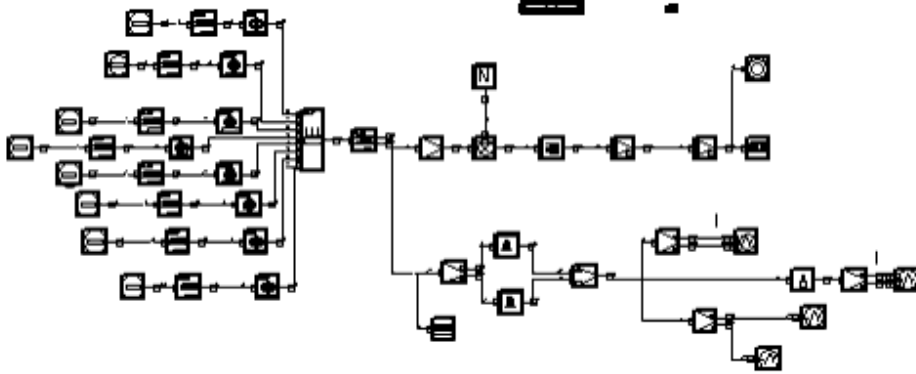

## GSM\_Measurement\_TCH

### Specifications

Symbol	Specification	Simulation Type	Value	Unit
M	GMSK modulation sample rate	ADS Ptolemy	2	N/A
TSC	training sequence code	ADS Ptolemy	0	N/A
TStep	output time step for channel model	ADS Ptolemy	3.692/16	μsec

### Notes

- GMSK constellation diagram can be displayed by oversampled data (for example, 8 samples/symbol) or by one sample per symbol. When the output constellation is displayed by one sample per symbol, the downsample model is designed to get the optimum sample.
- For ACPR and data, open dds files:
  - *Measurement\_TCH\_wrk\ACPR.dds*
  - *Measurement\_TCH\_wrk\GSM\_Measurement\_TCH.dds*
- M=0, 1, 2 indicates the GMSK modulation sample rate of 4, 8, 16 samples per symbol.
- TStep must be related to M, that is  $TStep = 3.69 / \text{Samplerate} \mu\text{sec}$ .

### Simulation Results

- I-Q Measurement ([Constellation Diagram of ADS Simulation Results \(0.3 GMSK, 4 samples per symbol\)](#))

By collecting all sample points, the ideal GMSK constellation would be a circle.



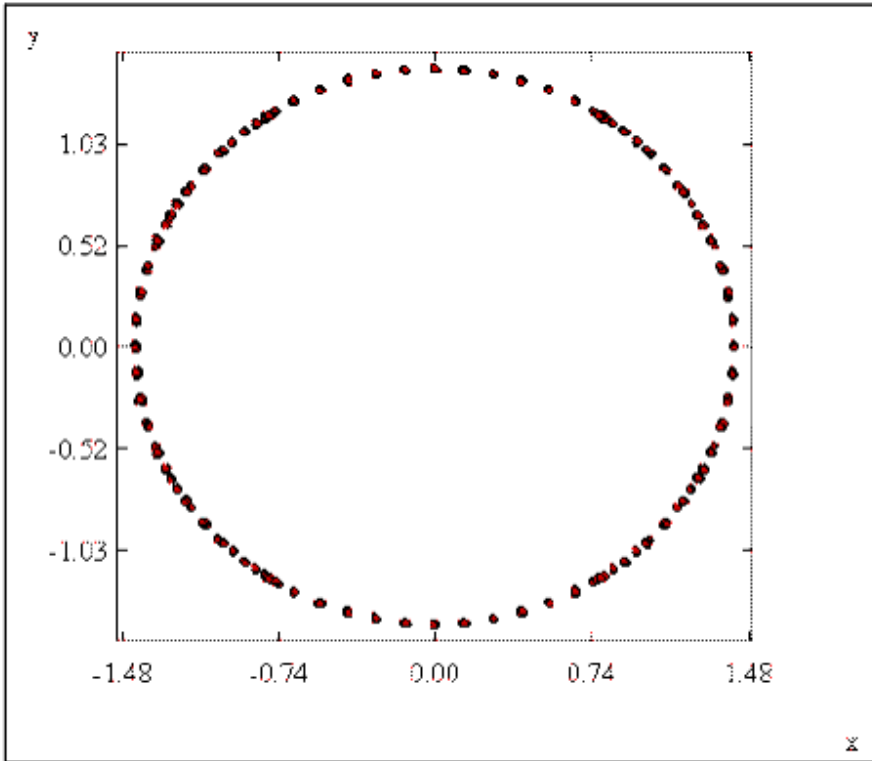

Constellation Diagram of ADS Simulation Results (0.3 GMSK, 4 samples per symbol)

- Eye Diagram ([Eye Diagram of 0.3 GMSK Modulation](#))

The eye diagram of GMSK signal is ideal and consistent with the measurement results of the Agilent 89441 instrument.

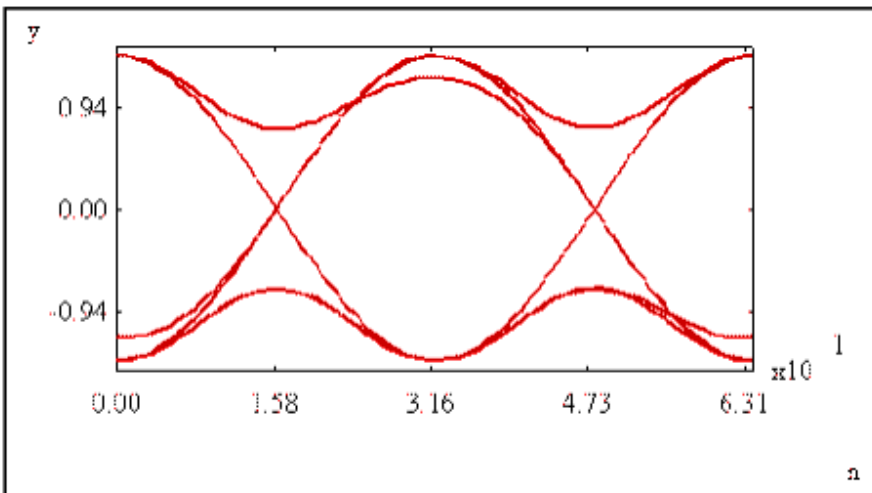

Eye Diagram of 0.3 GMSK Modulation

- Spectrum ([Magnitude and Spectrum of GMSK Modulation](#))

The spectrum of GMSK modulation at 935.2 MHz complies with the specification.

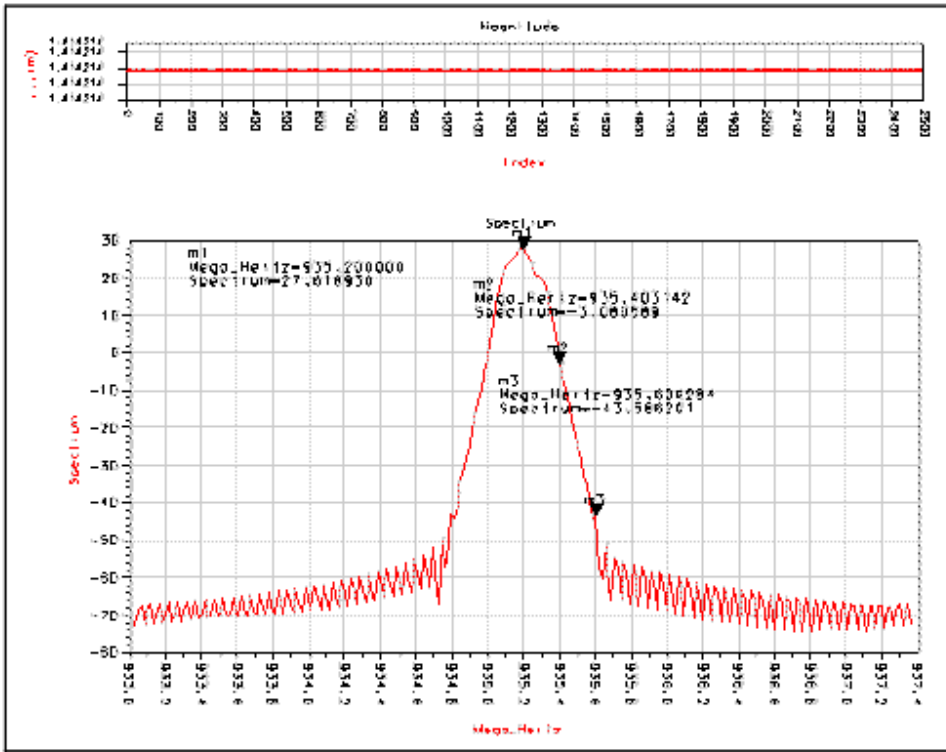

### Magnitude and Spectrum of GMSK Modulation

#### Test Limits for Spectrum Due to Modulation

Distance from Carrier (kHz)	0	100	200	400
Maximum Relative Level (dBc)	0	+0.5	-30	-60

- ACPR ([ACPR Measurement after Simulation](#))

ACPR calculation using resolution bandwidth. The power in the main channel is integrated over its bandwidth; the adjacent channel power is calculated at 30 kHz resolution bandwidth and zero span. The ACPR is expressed as a power ratio or dbc.



- Hardware platform: Pentium Pro 200 MHz, 96 MB memory
- Software platform: Windows NT 4.0 Workstation, Advanced Design System 1.1
- Data points: 2496 frames
- Simulation time: approximately 90 seconds

# Random Access Channel

## RACHsys\_wrk Design Names

- GSM\_RACH

## Features

- GSM propagation fading channel and additive white Gaussian noise
- Random access channel
- GMSK modulator and MLSE equalizer
- Gaussian noise with adjustable noise variance
- BER and FER performance stored in NumericSink

## Description

This example shows the system performance of BER and FER on random access channel. It consists of error correction coding and decoding, data framing and deframing, GMSK modulation, GSM fading channel plus additive white Gaussian noise, 7-order Butterworth filter, bit synchronization and maximum-likelihood sequence estimation receiver.

In random access channel, a cyclic code and a convolutional code with tail bits are used; interleaving models are not used. Each eight data bits are transformed into 36 bits after channel coding.

For details about framing, GMSK modulation, synchronization and MLSE reception, refer to *Traffic Channel for Data Transmission at 9.6 kbps*.

## Schematics

[GSM\\_RACH](#) shows the schematic for this design. The data source is a random bit sequence (B1). [GSM\\_RACH\\_Encoder\\_Subnetwork](#) is the GSM\_RACH\_Encoder subnetwork used in [GSM\\_RACH](#). The number of input and output bits of cyclic encoder are 8 and 14, respectively; four tail bits are added to the cyclic coded data. These 18 bits are convolutionally encoded to 36 bits with constraint length of 5 and rate of 1/2. [GSM\\_RACH\\_Decoder\\_Subnetwork](#) shows the GSM\_RACH\_Decoder subnetwork.

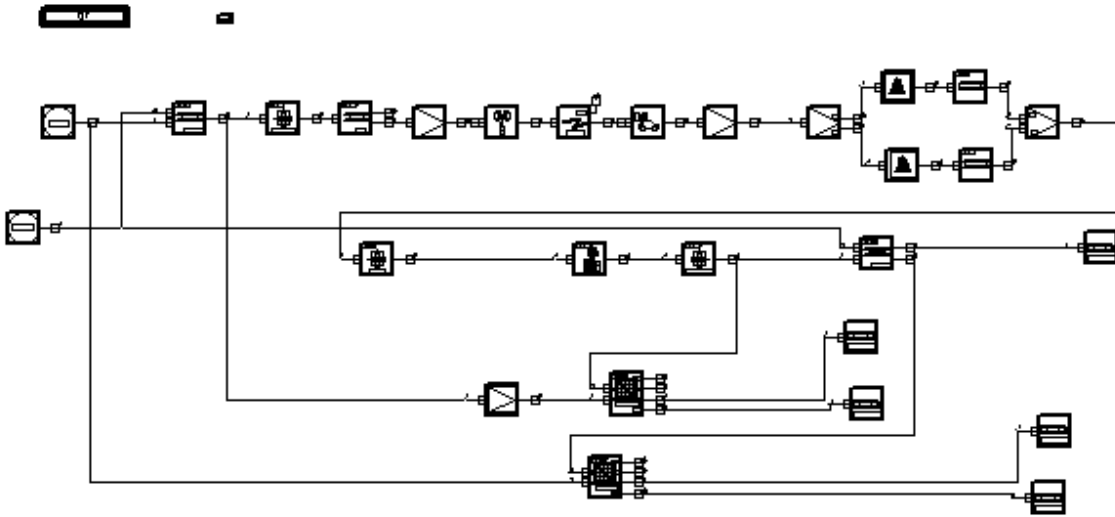

**GSM\_RACH**

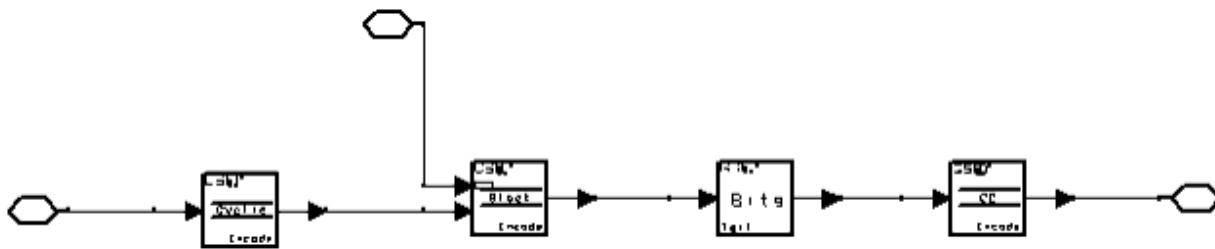

**GSM\_RACH\_Encoder Subnetwork**

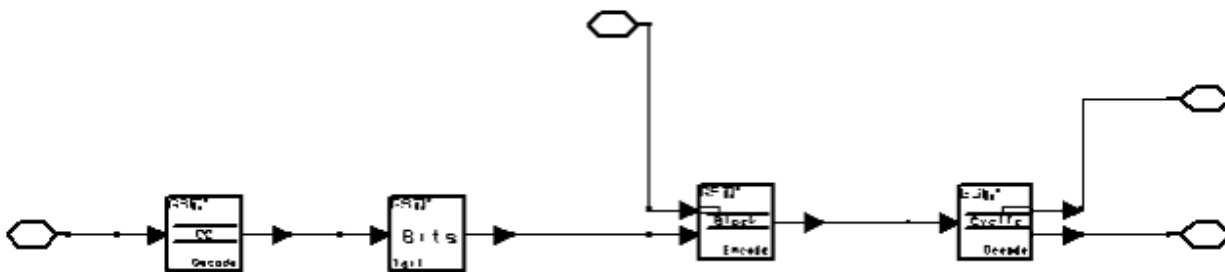

**GSM\_RACH\_Decoder Subnetwork**

**Specifications**

Symbol	Specification	Simulation Type	Value	Unit
Pc	power per bit	ADS Ptolemy	1	W
S	sample rate	ADS Ptolemy	8	N/A
TStep	output time step for channel model	ADS Ptolemy	3.692/8	μsec

## Notes

- TStep must be related to S, that is  $TStep = 3.69 / \text{SampleRate}$  μsec.

## Simulation Results

[BER Performance of Random Access Channel System](#) shows the bit error with and without channel coding. The BER performance of the system with channel coding is much better than the BER performance without channel coding.

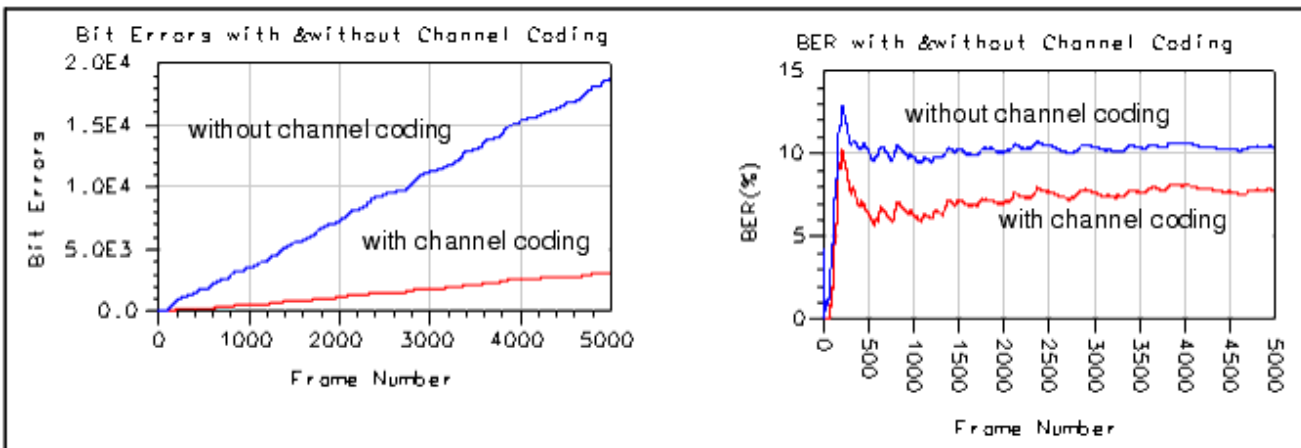

## BER Performance of Random Access Channel System

### Benchmark

- Hardware platform: Pentium Pro 200 MHz, 96 MB memory
- Software platform: Windows NT 4.0 Workstation, Advanced Design System 1.1
- Data points: 6000 frames
- Simulation time: approximately 8 hours

# Slow Associated Control Channel

## SACCHsys\_wrk Design Name

- GSM\_SysSACCH

## Features

- GSM propagation fading channel and additive white Gaussian noise
- Slow associated control channel
- Channel interleaving and de-interleaving
- GMSK modulator and MLSE equalizer
- Gaussian noise with adjustable noise variance
- BER and FER performance stored in NumericSink

## Description

This example shows the system performance of BER and FER on slow associated control channel. It consists of error correction coding and decoding, interleaving and de-interleaving, data framing and deframing, GMSK modulation, GSM fading channel plus additive white Gaussian noise, 7-order Butterworth filter, bit synchronization and maximum-likelihood sequence estimation receiver.

In the slow associated control channel, a Fire code with tail bits, a convolutional code and block rectangular interleaver are used. Each 184 data bits are transformed into 456 bits after channel coding and interleaving.

For details about framing, GMSK modulation, synchronization and MLSE reception, refer to *Traffic Channel for Data Transmission at 9.6 kbps*.

## Schematics

[GSM\\_SysSACCH](#) shows the BER and FER measurement for SACCH transmission and reception. Data source is a random bit sequence (B1).

[GSM\\_SACCH\\_Encoder\\_Subnetwork](#) is the GSM\_SACCH\_Encoder sub-network used in [GSM\\_SysSACCH](#) (detailed implementation of channel coding and interleaving for the slow associated control channel). The number of input and output bits of cyclic encoder are 184 and 224, respectively; four tail bits are added to the cyclic coded data. These 228 bits are convolutionally encoded to 456 bits with constraint length of 5 and rate of 1/2. GSM\_Interleaver\_4 is used to interleave the input 456 bits into four blocks.

[GSM\\_SACCH\\_Decoder\\_Subnetwork](#) shows the GSM\_SACCH\_Decoder subnetwork.



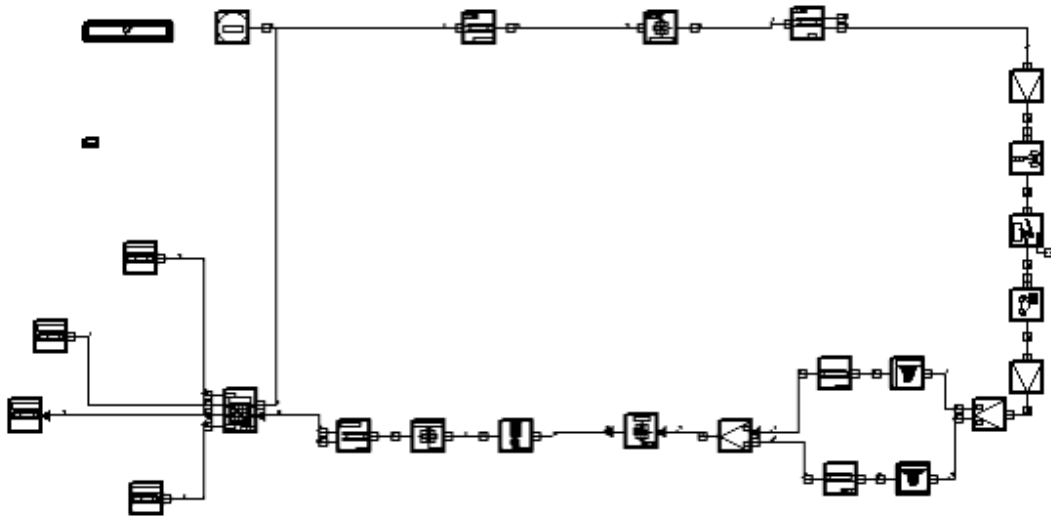

GSM\_SysSACCH

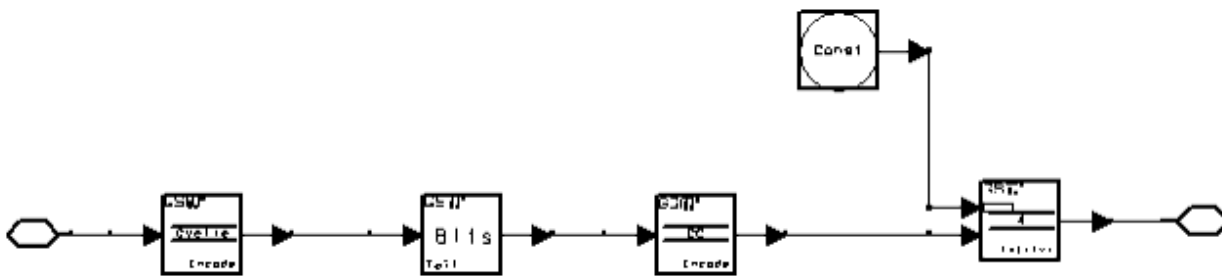

GSM\_SACCH\_Encoder Subnetwork

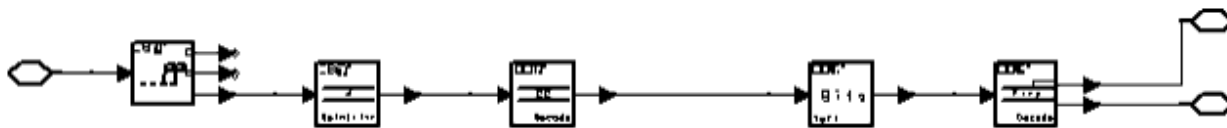

GSM\_SACCH\_Decoder Subnetwork

Specifications

Symbol	Specification	Simulation Type	Value	Unit
Pc	power per bit	ADS Ptolemy	1e-3	W
SampleRate	sample rate	ADS Ptolemy	8	N/A
TStep	output time step for channel model	ADS Ptolemy	3.692/8	µsec

**Notes**

- TStep must be related to SampleRate, that is  $TStep = 3.69 / \text{SampleRate}$   $\mu\text{sec}$ .

**Simulation Results**

[BER and FER of Slow Associated Control Channel](#) shows the bit error and BER, and the frame error and FER.

**Test Conditions**

- Channel Type: TU50 (urban area, 50 km/hr)
- SNR: 16.9 dB
- Test results of FER: 0.56%
- Recommended (GSM Specification 05.05) FER: 8%

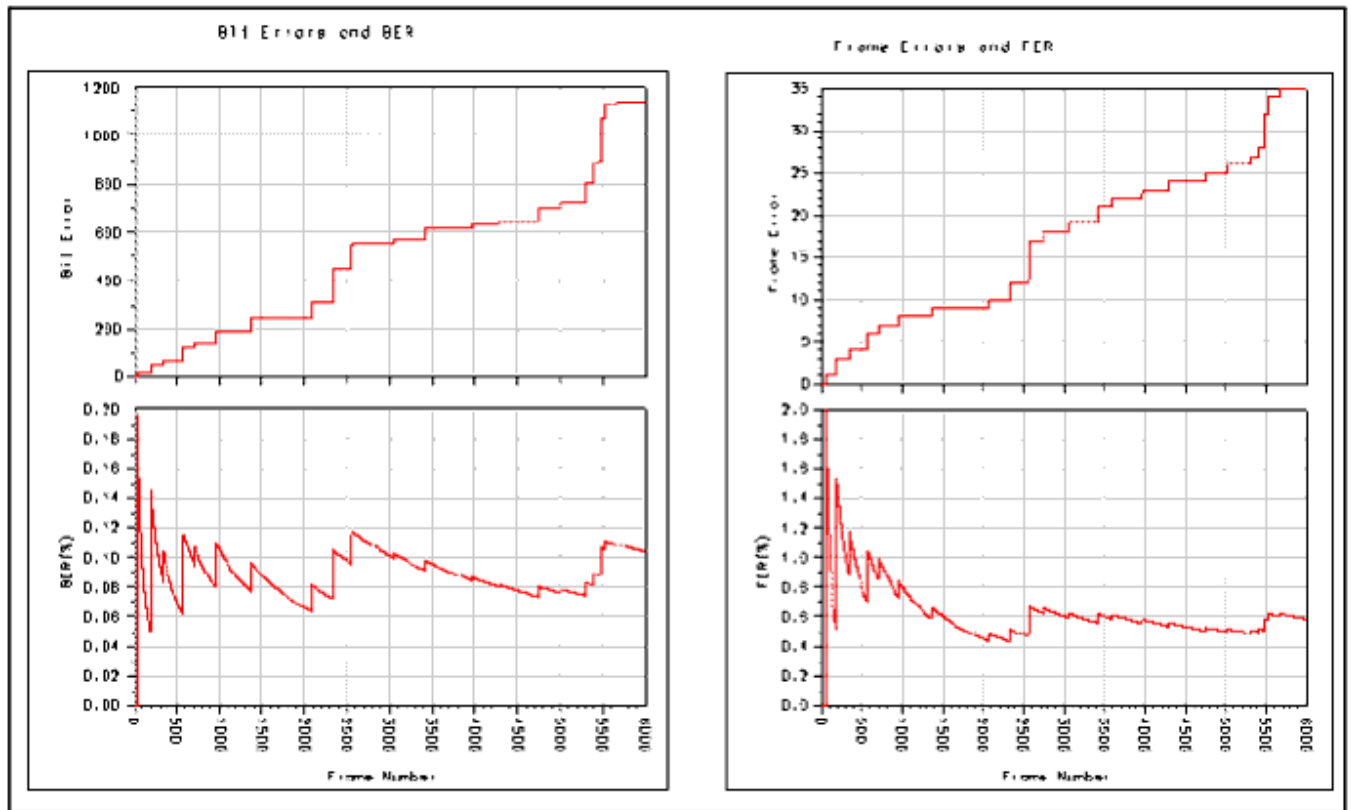

**BER and FER of Slow Associated Control Channel**

**Benchmark**

- Hardware Platform: Pentium Pro 200 MHz, 96 MB memory
- Software Platform: Windows NT 4.0 Workstation, Advanced Design System 1.1
- Data Points: 6000 frames
- Simulation Time: Approximately 8 hours

# Synchronization Channel

## SCHsys\_wrk Design Name

- GSM\_SysSCH

## Features

- GSM propagation fading channel and additive white Gaussian noise
- Synchronization channel
- GMSK modulator and MLSE equalizer
- Gaussian noise with adjustable noise variance
- BER and FER performance stored in NumericSink

## Description

This example shows the system performance of BER and FER on synchronization channel. It consists of error correction coding and de-interleaving, data framing and deframing, GMSK modulation, GSM fading channel plus additive white Gaussian noise, 7-order Butterworth filter, bit synchronization and maximum-likelihood sequence estimation receiver.

In the synchronization channel, a cyclic code and a convolutional code with tail bits are used; interleaving models are not used. Each 25 data bits are transformed into 78 bits after channel coding.

For details about framing, GMSK modulation, synchronization and MLSE reception, refer to *Traffic Channel for Data Transmission at 9.6 kbps*.

## Schematics

[GSM\\_SysSCH](#) shows the schematic design of BER and FER measurement for the synchronization channel transmission and reception. Data source is a random bit sequence (B1).

[GSM\\_SCH\\_Encoder\\_Subnetwork](#) is the sub-network GSM\_SCH\_Encoder used in [GSM\\_SysSCH](#) (detailed implementation of channel coding for SCH). The number of input and output bits of cyclic encoder are 25 and 35, respectively; four tail bits are added to the cyclic coded data. These 39 bits are convolutionally encoded to 78 bits with constraint length of 5 and rate of 1/2. (Interleaving models are not used in SCH encoding.)

[GSM\\_SCH\\_Decoder\\_Subnetwork](#) shows the implementation of GSM synchronization channel decoder.

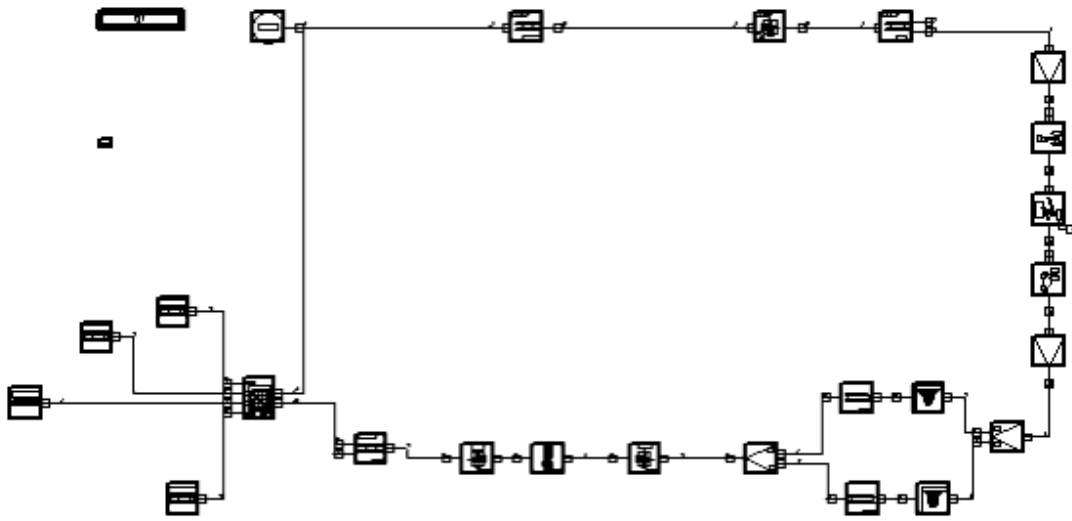

### GSM\_SysSCH



### GSM\_SCH\_Encoder Subnetwork



### GSM\_SCH\_Decoder Subnetwork

## Specifications

Symbol	Specification	Simulation Type	Value	Unit
GlobalPc	power per bit	ADS Ptolemy	1e-3	W
FCarrier	carrier frequency	ADS Ptolemy	900	MHz
SR	sample rate	ADS Ptolemy	8	N/A
TStep	output time step for channel model	ADS Ptolemy	3.692/8	μsec

## Notes

- TStep must be related to SR, that is  $TStep = 3.69/SR$   $\mu$ sec.

## Simulation Results

[BER and FER of Synchronization Channel](#) shows bit error and BER, and frame error and FER. Refer to GSM\_BerFer for BER and FER measurement methods.

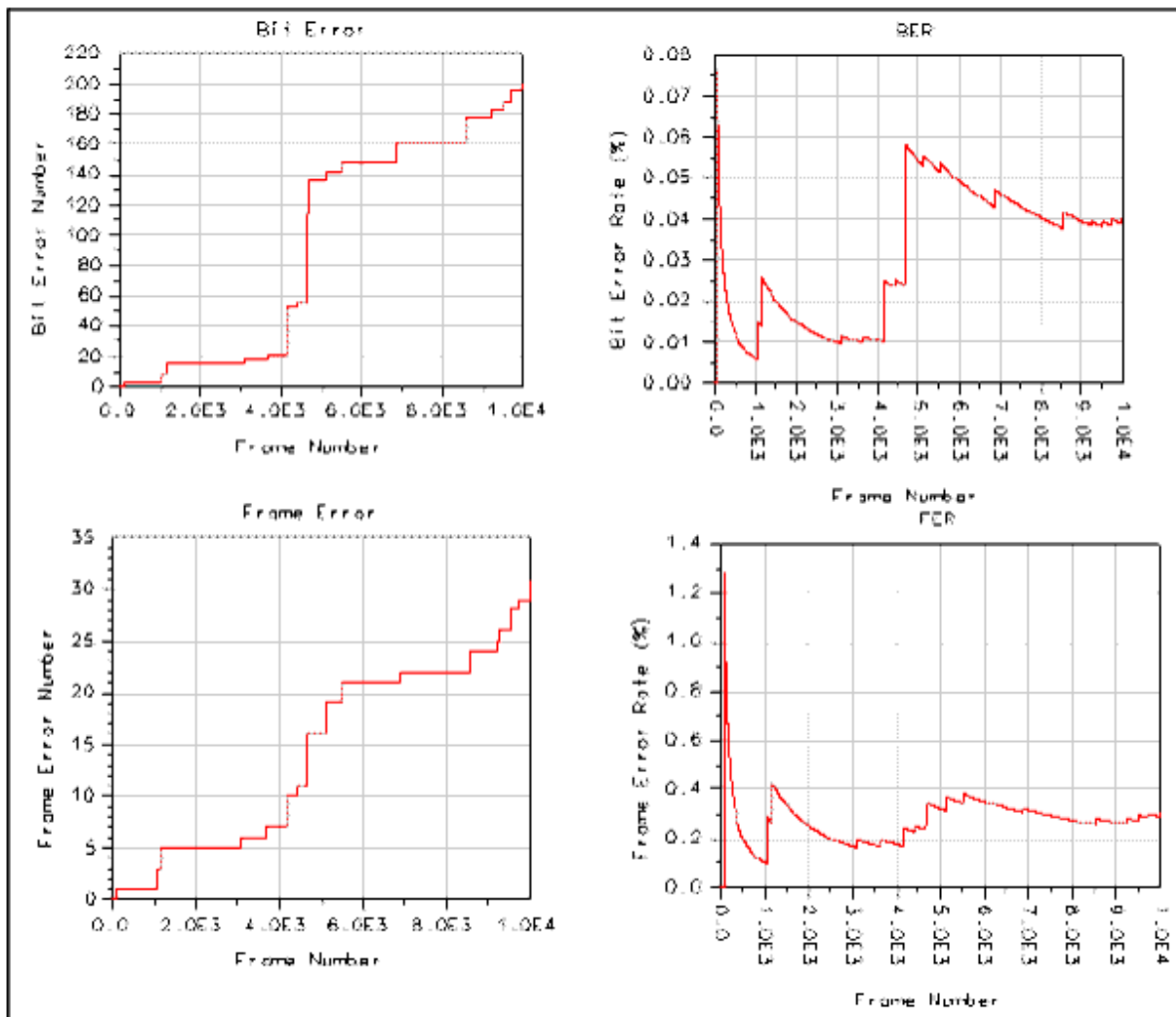

## BER and FER of Synchronization Channel

### Test Conditions

- Channel Type: TU50 (urban area, 50 km/hr)
- SNR: 16.9 dB
- Test results of FER: 0.31%
- Recommended (GSM Specification 05.05) FER: 17%

## Benchmark

- Hardware Platform: Pentium Pro 200 MHz, 96 MB memory
- Software Platform: Windows NT 4.0 Workstation, Advanced Design System 1.1
- Data Points: 10000 frames
- Simulation Time: approximately 16 hours

# Traffic Channel for Data Transmission at 2.4 kbps

## TCH24Sys\_wrk Design Name

- GSM\_Sys\_TCH24

## Features

- GSM propagation fading channel and additive white Gaussian noise
- Channel codec type: TCH 2.4 kbps
- Channel interleaving and de-interleaving
- GMSK modulator and maximum-likelihood sequence estimation equalizer
- Gaussian noise with adjustable noise variance
- BER and FER performance stored in NumericSink

## Description

This example shows the system performance of BER and FER on 2.4 kbps full-rate traffic channel (TCH/F2.4). It consists of error correction coding and decoding, interleaving and de-interleaving, data framing and deframing, GMSK modulation, GSM fading channel and additive white Gaussian noise channel, 7-order Butterworth filter, bit synchronization and maximum-likelihood sequence estimation receiver.

In transmission of TCH/F2.4, only a convolutional code with tail bits is used with block diagonal interleaving. Each 72 data bits are transformed into 456 bits after channel coding.

For details about framing, GMSK modulation, synchronization and MLSE reception, refer to *Traffic Channel for Data Transmission at 9.6 kbps*.

## Schematics

[GSM\\_Sys\\_TCH24](#) shows the schematic for this design. The data source is a random bit sequence (B1).

[GSM\\_TCHF24\\_Encoder\\_Subnetwork](#) is the GSM\_TCHF24\_Encoder sub-network used in [GSM\\_Sys\\_TCH24](#), i.e., detailed implementation of channel coding and interleaving for TCH 2.4 kbps. For each 72 data bits input, four tail bits are added. These 76 bits are convolutionally encoded to 456 bits with constraint length of 5 and rate of 1/6. The 456 coded bits are block diagonal interleaved over eight blocks. And after interleaving and inserting stealing flag bits, 464 bits are produced.

[GSM\\_TCHF24\\_Decoder\\_Subnetwork](#) shows the GSM\_TCHF24\_Decoder subnetwork, which



includes stealing flag removing, de-interleaving, Viterbi decoding and tail bits removing.

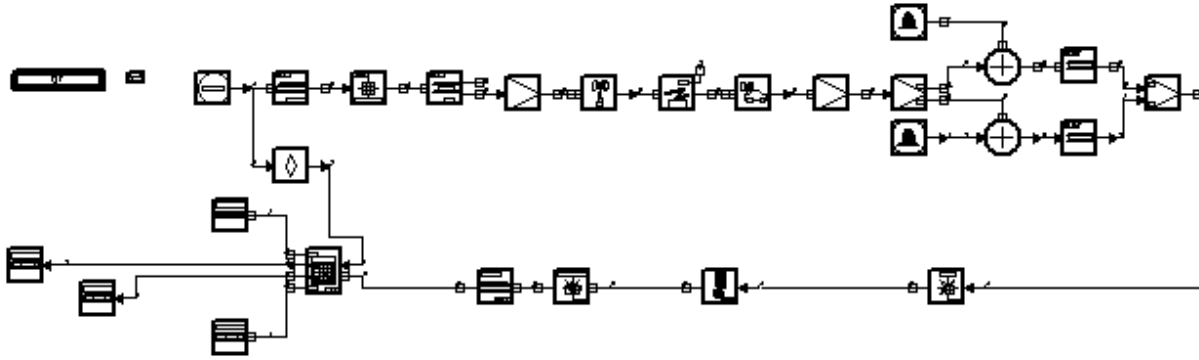

**GSM\_Sys\_TCH24**

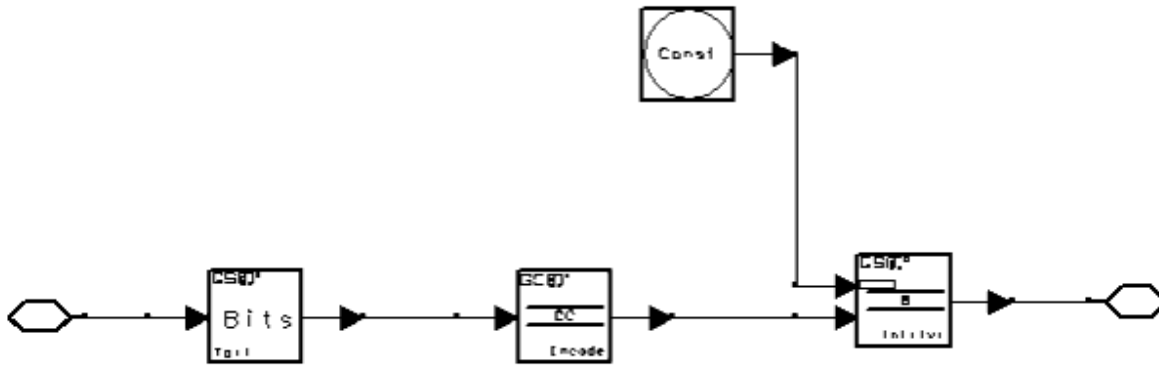

**GSM\_TCHF24\_Encoder Subnetwork**

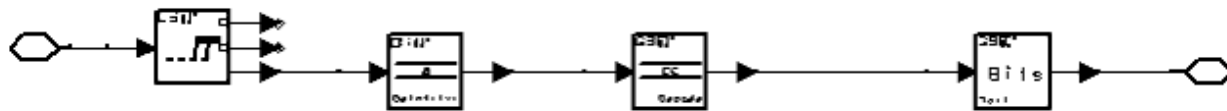

**GSM\_TCHF24\_Decoder Subnetwork**

**Specifications**

Symbol	Specification	Simulation Type	Value	Unit
GlobalPc	power per bit	ADS Ptolemy	1e-3	W
GlobalSampleRate	GMSK modulation sample rate	ADS Ptolemy	2	N/A
GlobalTSC	training sequence code	ADS Ptolemy	0	N/A
TStep	output time step for channel model	ADS Ptolemy	3.692/16	µsec

## Notes

- Sample Rate is 4, 8, or 16 when GlobalSampleRate is 0, 1 or 2, respectively.
- TStep must be related to GlobalSampleRate, that is  $\text{SampleRate}=16$  and  $\text{TStep}=3.69/\text{SampleRate}$  µsec.
- Since there are processing delays, the BER measurement starts after the first 72 bits output.

## Simulation Results

[BER and FER of TCH/F2.4](#) shows the bit error and BER, and the frame error and FER. Refer to GSM\_BerFer for the BER and FER measurement method.

## Test Conditions

- Channel Type: TU50 (urban area, 50 km/hr)
- SNR: 16.9 dB
- Test results of BER: 0.004%
- Recommended (GSM Specification 05.05) BER: 0.02%

## Benchmark

- Hardware Platform: Pentium Pro 200 MHz, 96 MB memory
- Software Platform: Windows NT 4.0 Workstation, Advanced Design System 1.1
- Data Points: 60000 frames
- Simulation Time: approximately 101 hours

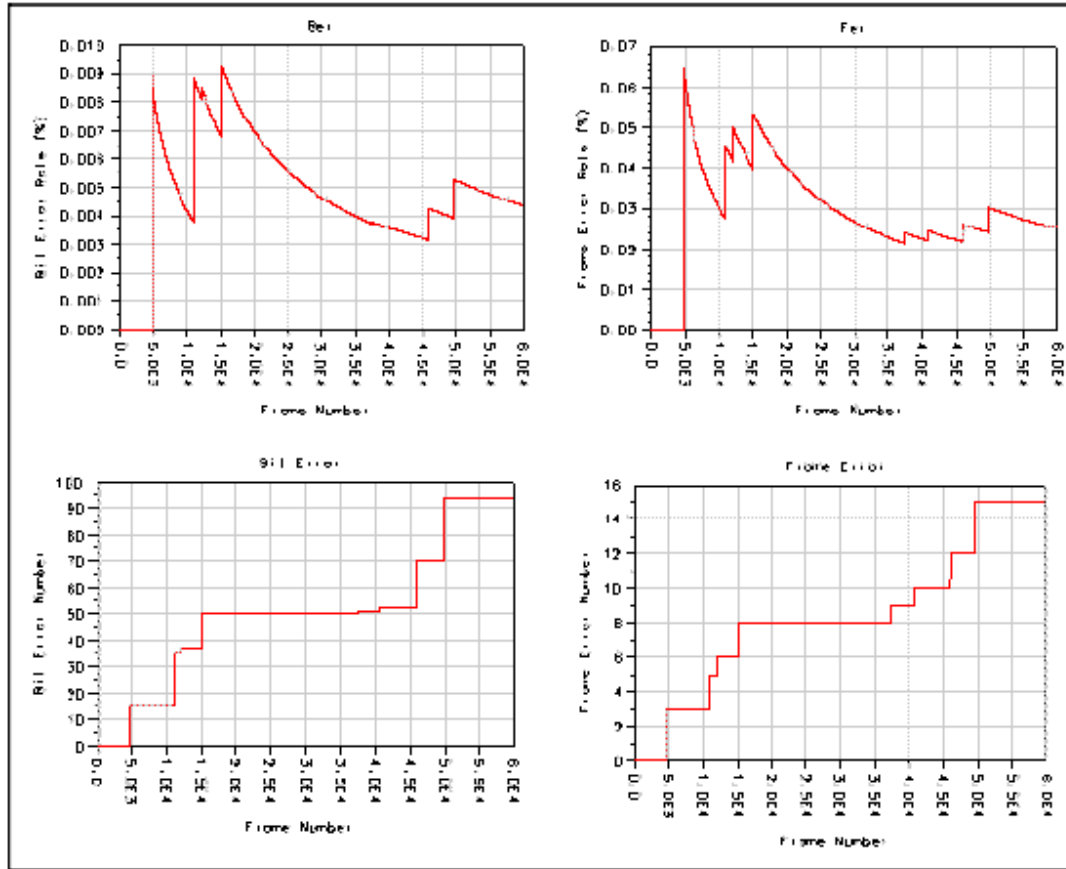

BER and FER of TCH/F2.4

# Traffic Channel for Data Transmission at 4.8 kbps

## TCH48Sys\_wrk Design Name

- GSM\_Sys\_TCH48

## Features

- GSM propagation fading channel and additive white Gaussian noise
- Channel codec type: TCH 4.8 kbps
- Channel interleaving and de-interleaving
- GMSK modulator and maximum-likelihood sequence estimation equalizer
- Gaussian noise with adjustable noise variance
- BER and FER performance stored in NumericSink

## Description

This example shows system performance of BER and FER on 4.8 kbps Full-rate Traffic Channel (TCH/F4.8). It consists of error correction coding and decoding, interleaving and de-interleaving, data framing and deframing, GMSK modulation, GSM fading channel and additive white Gaussian noise channel, 7-order Butterworth filter, bit synchronization and maximum-likelihood sequence estimation receiver.

In transmission of TCH/F4.8, only a convolutional code with tail bits is used with block diagonal interleaving. Each 15 data bits are transformed into 456 bits after channel coding.

For details about framing, GMSK modulation, synchronization and MLSE reception, refer to *Traffic Channel for Data Transmission at 9.6 kbps*.

## Schematics

[GSM\\_Sys\\_TCH48](#) shows the schematic for this design. Data source is a random bit sequence (B1).

[GSM\\_TCHF48 Encoder Subnetwork](#) is the GSM\_TCHF48\_Encoder subnetwork used in [GSM\\_Sys\\_TCH48](#) (detailed implementation of channel coding and interleaving for TCH 4.8 kbps). For each 15 data bits input, four tail bits are added. Eight blocks of these 16 bits are convolutionally encoded to 456 bits with constraint length of 5 and rate of 1/3. The 456 coded bits are divided into four blocks of 114 bits. Each block is divided into 19 sub-blocks and block diagonal interleaved over these 19 sub-blocks. After interleaving, inserting stealing flag bits, and combining the four blocks, 464 bits are produced.

[GSM\\_TCHF48\\_Decoder Subnetwork](#) shows GSM\_TCHF48\_Decoder sub-network, which includes stealing flag removing, de-interleaving, Viterbi decoding and tail bits removing.

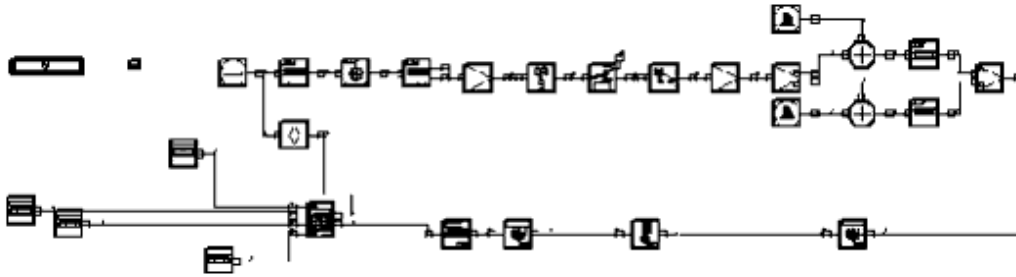

**GSM\_Sys\_TCH48**

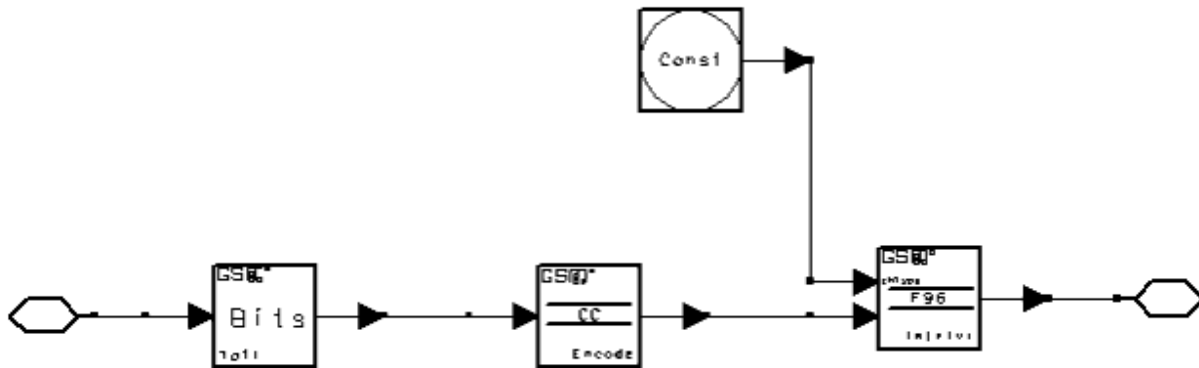

**GSM\_TCHF48\_Encoder Subnetwork**

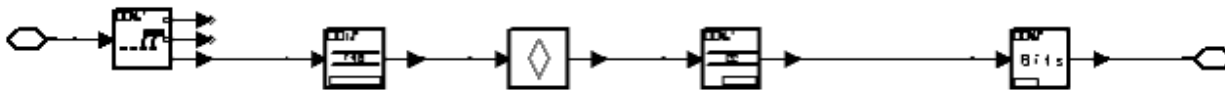

**GSM\_TCHF48\_Decoder Subnetwork**

**Specifications**

Symbol	Specification	Simulation Type	Value	Unit
GlobalPc	power per bit	ADS Ptolemy	1e-3	W
GlobalSampleRate	GMSK modulation sample rate	ADS Ptolemy	2	N/A
GlobalTSC	training sequence code	ADS Ptolemy	0	N/A
TStep	output time step for channel model	ADS Ptolemy	3.692/16	µsec

## Notes

- Sample Rate is 4, 8, 16 when parameter GlobalSampleRate is 0, 1 or 2, respectively.
- TStep must be related to GlobalSampleRate, that is SampleRate=16 and TStep=3.69/SampleRate  $\mu$ sec.
- Since there are processing delays, the BER measurement starts after first 600 bits output.

## Simulation Results

[BER and FER of TCH/F4.8](#) shows the bit error and BER, and the frame error and FER. Refer to GSM\_BerFer for the BER and FER measurement method.

## Test Conditions

- Channel Type: HT100 (hilly terrain, 100 km/hr)
- SNR: 14 dB
- Test results of BER: 0.009%
- Recommended (GSM Specification 05.05) BER: 0.01%

## Benchmark

- Hardware Platform: Pentium Pro 200 MHz, 96 MB memory
- Software Platform: Windows NT 4.0 Workstation, Advanced Design System 1.1
- Data Points: 20000 frames
- Simulation Time: approximately 32 hours

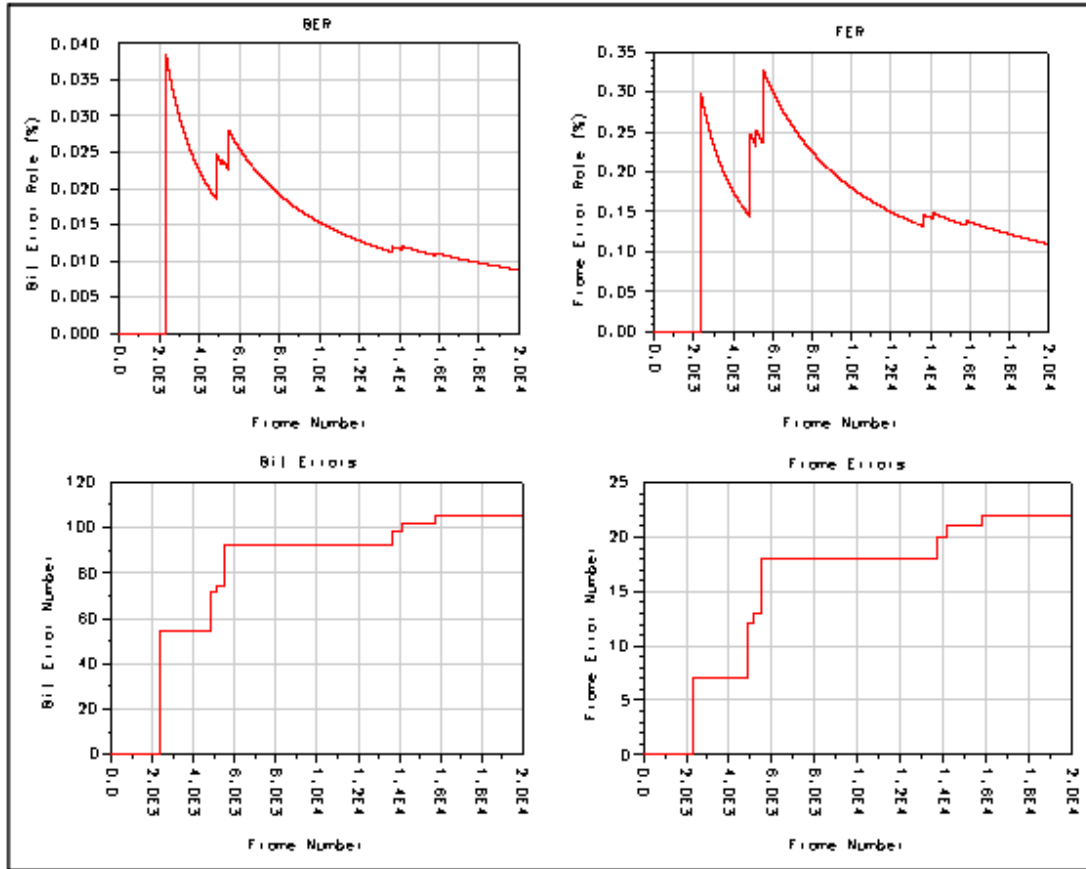

BER and FER of TCH/F4.8

# Traffic Channel for Data Transmission at 9.6 kbps

## TCH96Sys\_wrk Design Name

- GSM\_Sys\_TCH96

## Features

- GSM propagation fading channel and additive white Gaussian noise
- Channel codec type: TCH/F9.6
- Channel interleaving and de-interleaving
- GMSK modulator and maximum-likelihood sequence estimation equalizer
- Gaussian noise with adjustable noise variance
- BER and FER performance stored in NumericSink

## Description

This example shows the system performance of BER and FER on 9.6 kbps full-rate traffic channel (TCH/F9.6). It consists of error correction coding and decoding, interleaving and de-interleaving, data framing and deframing, GMSK modulation, GSM channel, 7-order Butterworth filter, bit synchronization, maximum-likelihood sequence estimation receiver.

The system source is a random bit source. Input data is convolutionally coded at rate 1/2, interleaved, and fed into a normal burst construction component. After training sequence, tail bits and guard time bits are added, data is placed in a GMSK modulation model. In this example only one user is considered. The channel contains propagation fading channel and additive white Gaussian noise channel. Twelve channel types can be selected with adjustable parameters such as velocity, antenna height, and location.

In the receiver, the signal is filtered by 7-order Butterworth filter (designed by the DSP Filter Designer of Agilent Advanced Design System). The bit synchronization model is designed to select the optimum sample in a symbol that is transferred to an MLSE receiver. After signal recovery in the maximum-likelihood sequence estimation receiver, burst disassembly, de-interleaving and channel decoding, the system BER and FER are measured.

## Schematics

[GSM\\_Sys\\_TCH96](#) shows the schematic for this design. Data source is a random bit sequence (B1).

[GSM\\_TCHF96\\_Encoder\\_Subnetwork](#) shows the GSM\_TCHF96\_Encoder subnetwork used in [GSM\\_Sys\\_TCH96](#) (detailed implementation of channel coding and interleaving of traffic



channel for data transmission at 9.6 kbps). For each 240 data bits input, four tail bits are added. These 244 bits are convolutionally encoded to 488 bits with constraint length of 5 and rate of 1/2; 32 of the 488 coded bits are punctured. The remaining 456 bits are first divided into four 114-bit length blocks. Each block is then divided into 19 sub-blocks and block diagonal interleaved over these 19 sub-blocks. After interleaving, inserting stealing flag bits and combining the four blocks, 464 bits are produced.

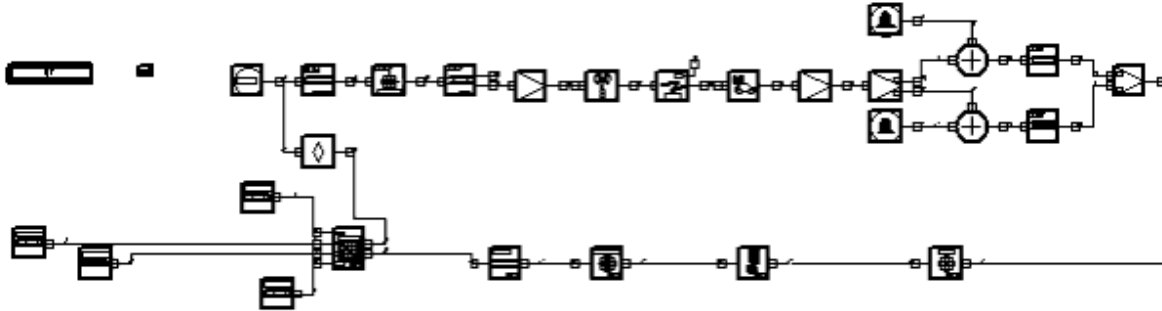

#### GSM\_Sys\_TCH96

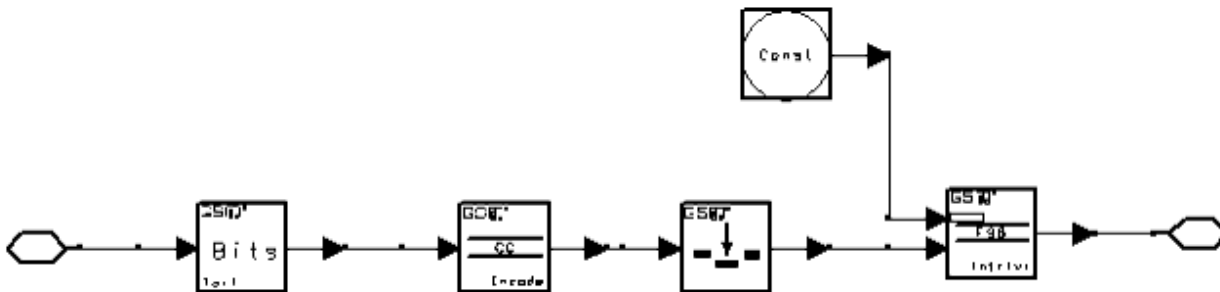

#### GSM\_TCHF96\_Encoder Subnetwork

[GSM\\_GMSKMod Subnetwork](#) shows the GSM\_GMSKMod subnetwork (BT=0.3), which includes:

- GSM\_DifferEncoder to implement differential encoding of the input bits, which is required in GSM specification to generate GMSK signal. According to the GSM specification 05.04, the initial value of the first bit is assigned to 1. After the differential encoding, the model maps 0 to 1, 1 to -1.
- GSM\_Rom to generate the modulated signal of I, Q branches.
- GSM\_Carrier to generate the modulated signal in complex envelope equivalent and carrier frequency.

[GSM\\_SynNBurst Subnetwork](#) shows the GSM\_SynNBurst subnetwork. It includes data selection, phase recovery, and sampler. The phase recovery model correlates the received and the local training sequence to estimate the timing offset and determine an index. The sampler outputs the optimum sample from over-sampled modulated data according to the index from phase recovery.

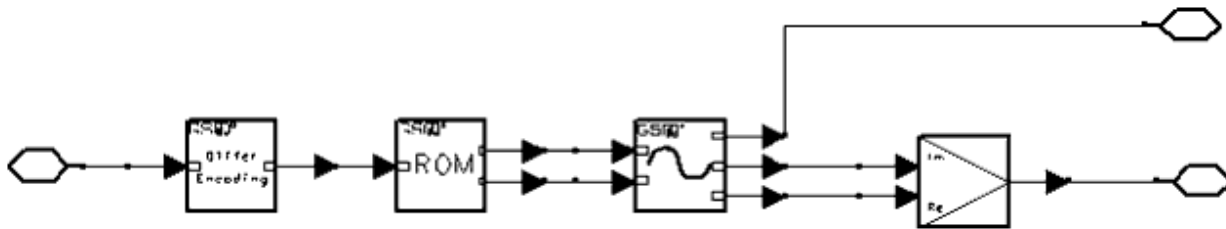

### GSM\_GMSKMod Subnetwork

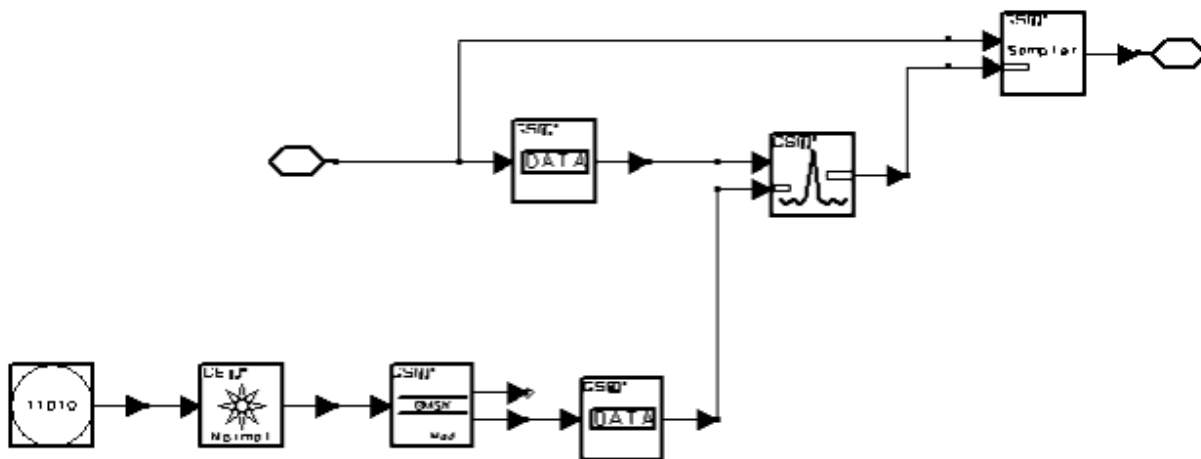

### GSM\_SynNBurst Subnetwork

[Sub-Network of GSM Adaptive Equalizer](#) shows the implementation of GSM receiver used to demodulate and restore the data sequence from the received and synchronized signals in the presence of intersymbol interference. The equalizer used here is based on maximum-likelihood sequence estimation and a modified version of Viterbi algorithm.

[GSM\\_TCHF96 Decoder Subnetwork](#) shows the GSM\_TCHF96\_Decoder subnetwork. It includes stealing flag removing, block diagonal de-interleaving, depuncturing, convolutional code decoding, and tail bits removing. In depuncturing, 32 bits of zeros replace the punctured bits.

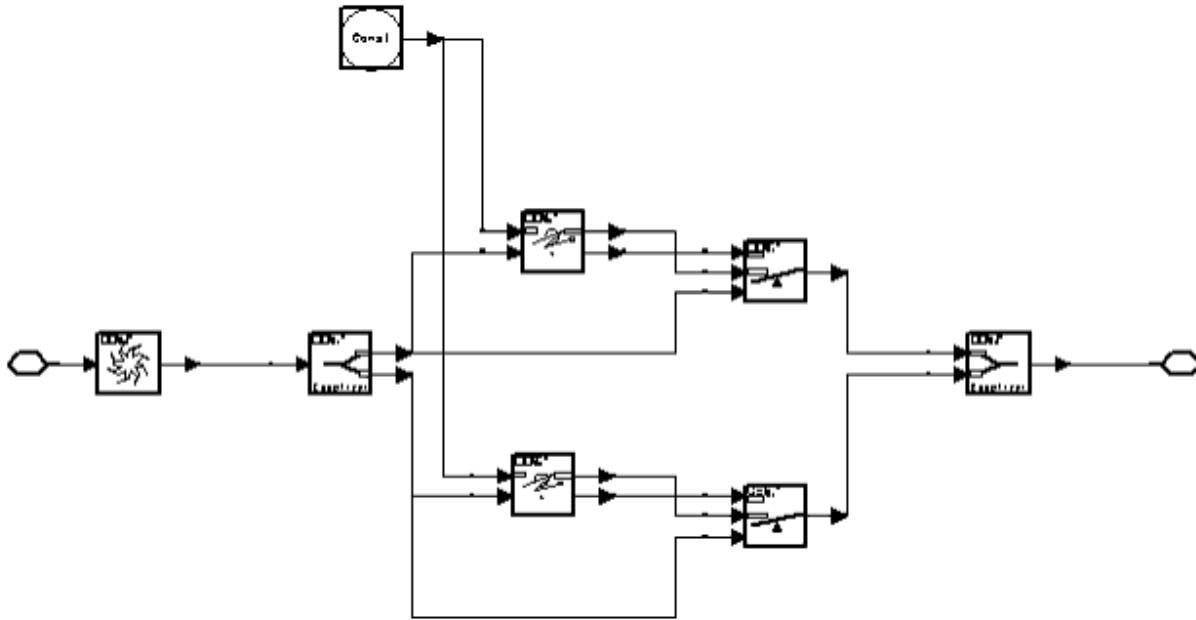

Sub-Network of GSM Adaptive Equalizer

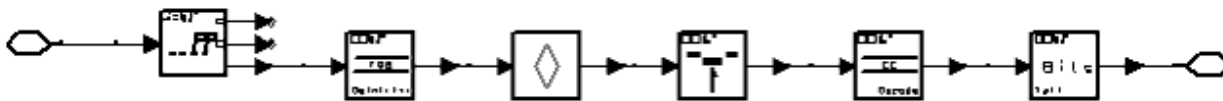

GSM\_TCHF96\_Decoder Subnetwork

**Specifications**

Symbol	Specification	Simulation Type	Value	Unit
GlobalPc	power per bit	ADS Ptolemy	1e-3	W
GlobalSampleRate	GMSK modulation sample rate	ADS Ptolemy	2	N/A
GlobalTSC	training sequence code	ADS Ptolemy	0	N/A
TStep	output time step for channel model	ADS Ptolemy	3.692/16	µsec

**Notes**

- The Sample Rate is 4, 8, or 16, when the GlobalSampleRate parameter is 0, 1, or 2, respectively.
- The TStep must be related to GlobalSampleRate, that is  $SampleRate=16$ ,  $TStep=3.69/SampleRate$  µsec.
- Since there are processing delays, the BER measurement starts after the first 1200 bits output.

## Simulation Results

[BER and FER of TCH/F9.6 System](#) shows the bit error and BER, and the frame error and FER. Refer to GSM\_BerFer documentation for the BER and FER measurement method.

## Test Conditions

- Channel Type: TU50 (urban area, 50 km/hr)
- SNR: 16.9 dB
- Test results of BER: 0.041%
- Recommended (GSM Specification 05.05) BER: 0.1%

## Benchmark

- Hardware Platform: Pentium Pro 200 MHz, 96 MB memory
- Software Platform: Windows NT 4.0 Workstation, Advanced Design System 1.1
- Data Points: 10000 frames
- Simulation Time: approximately 22 hours

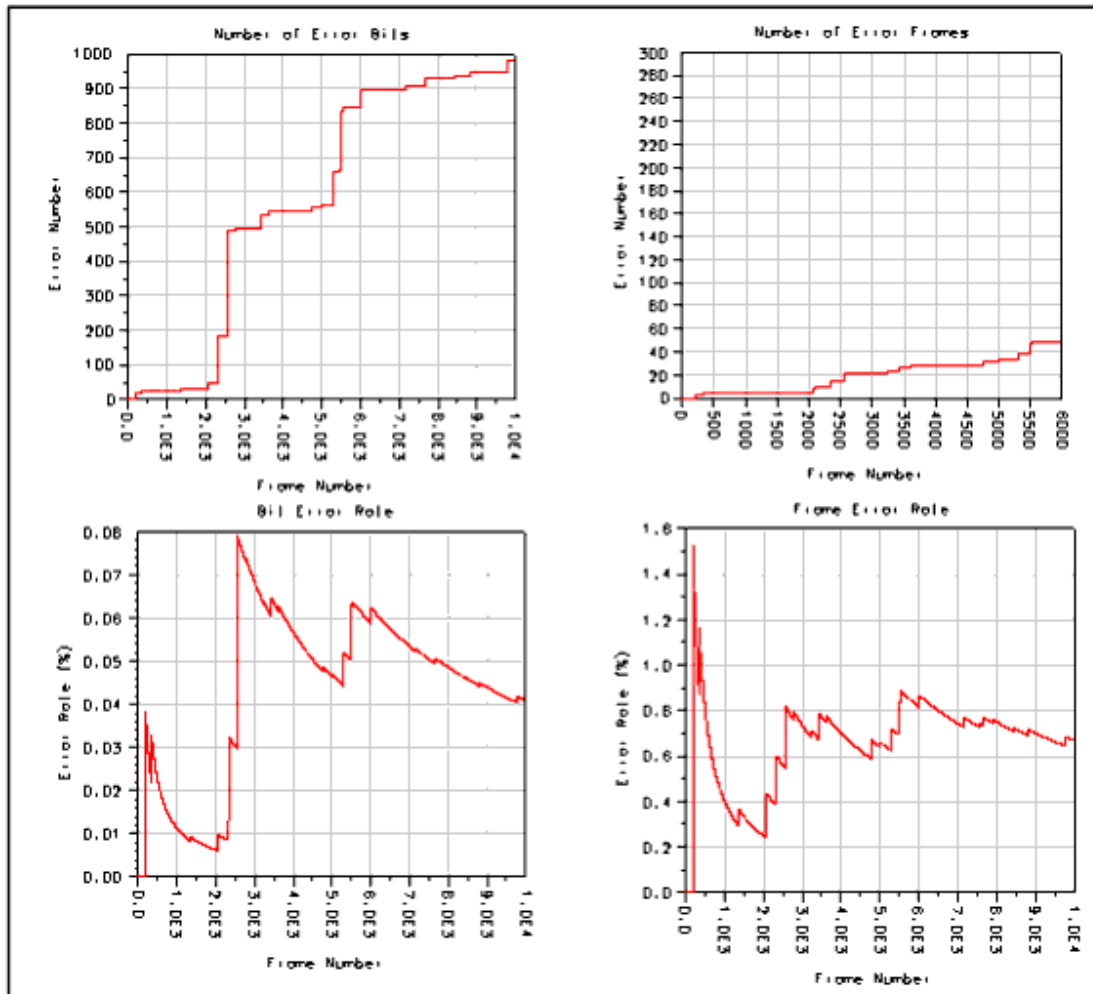

**BER and FER of TCH/F9.6 System**

# Channel Codec for TCH/FS

## TCHFS\_Codec\_wrk Design Name

- GSM\_ChannelCodec

## Features

- Channel codec for TCH/FS
- Output of channel decoding, frame error flag, and BER with channel coding
- Channel interleaving and de-interleaving
- BER performance of each frame stored in NumericSink
- Random bit source as noise

## Description

This design shows channel encoding and decoding of TCH/FS (full rate speech traffic channel), including cyclic code encoding and decoding, convolutional code encoding and decoding, reordering and inverse reordering, and block diagonal interleaving and de-interleaving.

First, the input is split into three parts (Ia, Ib and II) by two splitters. Part Ia (50 bits) is cyclic encoded; part Ib (132 bits) is not cyclic encoded. The combined Ia and Ib parts, the most critical bits, are half-rate convolutionally encoded after tail bits are added. Combined with the 78 part II bits, the data (entire block length is 456 bits) is fed into the diagonal interleaver.

Noise is generated by a random source with an adjustable number of ones. Noise is added to coded data by LogicXor. After de-interleaving and decoding, the BER is measured.

## Schematics

[Schematic Design of TCH/FS Channel Codec](#) shows the TCH/FS encoding and decoding system schematic.

[Sub-network of GSM TCH/FS Channel Encoder](#) is the GSM\_TCHFS\_Encoder subnetwork used in [Schematic Design of TCH/FS Channel Codec](#) (detailed implementation of channel coding and interleaving for TCH).

[Sub-network of GSM TCH/FS Channel Decoder](#) shows the GSM\_TCHFS\_Decoder.



## Specifications

Symbol	Specification	Simulation Type	Value
InitBER	rate of bit errors added to channel coded data	ADS Ptolemy	0.05

## Notes

- Because of processing delays, the BER measurement begins after first 260-bit output.

## Simulation Results

The upper curve in [Error Correction Performance of TCH/FS Channel Coding](#) shows the rate of bit errors added to channel coded data. In this example the added BER is set to 5%. The lower curve is the BER measurement of the output of channel decoder. Because of the function of error correction of channel coding, it is lower than the rate of added bit errors because some errors have been corrected by channel coding.

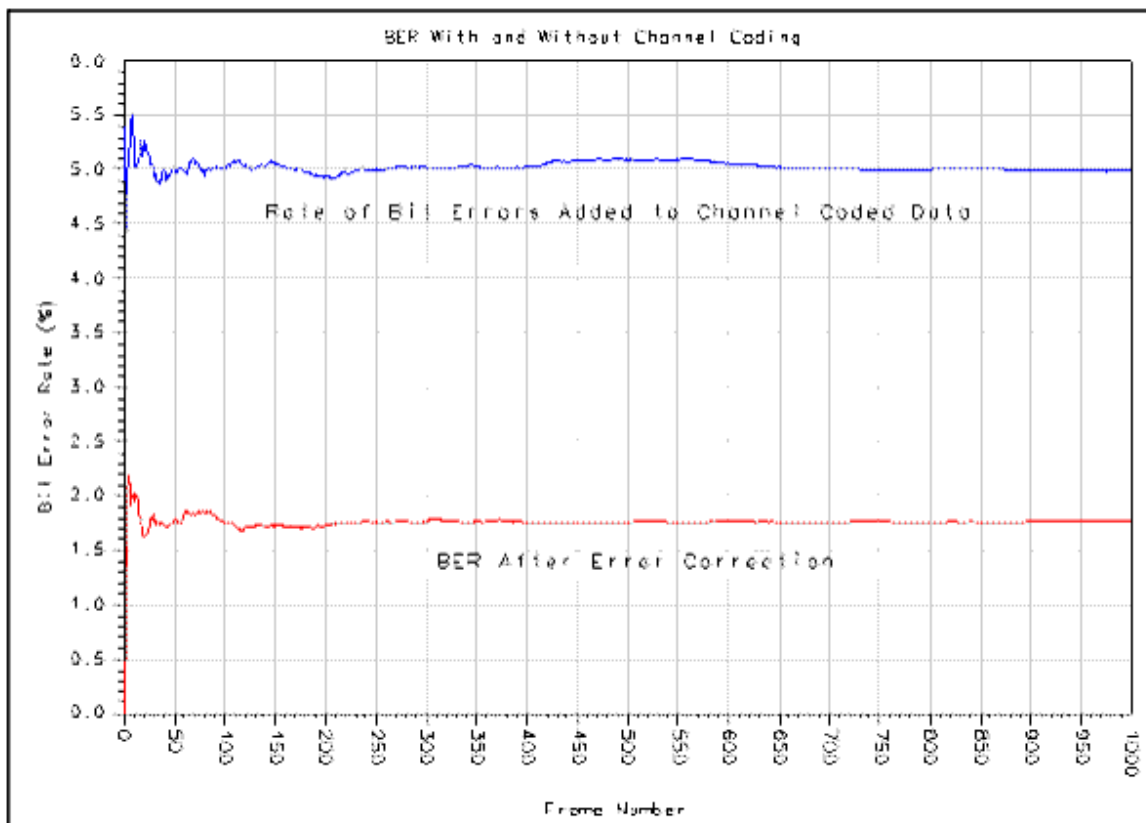

## Error Correction Performance of TCH/FS Channel Coding

## Benchmark



- Hardware Platform: Pentium Pro 200 MHz, 96 MB memory
- Software Platform: Windows NT 4.0 Workstation, Advanced Design System 1.1
- Data Points: 1000 frames
- Simulation Time: approximately 1 minute

# Transmission and Reception of Traffic Channel/Full-Rate Speech

## TCHFSsys\_wrk Design Name

- GSM\_TCHFS

## Features

- Displays output of channel decoding, frame error flag, and BER with and without channel coding
- Fading channel with additive white Gaussian noise
- Adaptive equalizer using maximum-likelihood sequence estimation
- Bit synchronization using correlation method
- BER of each frame stored in NumericSink

## Description

This example demonstrates transmission and reception of traffic channel/full-rate speech (TCH/FS). The type of the burst in this example is normal burst. A random bit source component is used as a full rate (13 kbps) speech data source.

Transmission includes channel coding, normal burst construction, and GMSK modulation. Channel coding for TCH/FS includes a cyclic encoder, a convolutional code encoder, a channel interleaver and a re-orderer, two splitters that split input data into blocks of different classes, and a combiner that combines these blocks after coding. Before passing channel, a GMSK modulator is applied. The channel used is a GSM propagation fading channel. The type of channel, path loss, height of antenna, gain of antenna, position and speed of the mobile station are user-settable parameters. A Gaussian noise in complex envelope is added to the received signal.

The receiver includes a Butterworth filter, a normal burst synchronizer, an equalization receiver, normal burst disassembly, and a channel decoder. The equalization receiver is an adaptive equalizer that uses maximum-likelihood sequence estimation. The channel decoder includes a channel de-interleaver, decoders for convolutional and cyclic code, a splitter, and a combiner.

The BER of channel coded data is measured and compared to data without channel coding.

## Schematics

[Schematic of Traffic Channel/Full-rate Speech \(TCH/FS\)](#) shows the schematic of the

transmission and reception of traffic channel/full-rate speech. [Subnetwork of Channel Coder for TCH/FS](#) shows the subnetwork of the channel encoder for the TCH/FS. [Subnetwork of Channel Decoder for TCH/FS](#) shows the subnetwork of the channel decoder for TCH/FS.

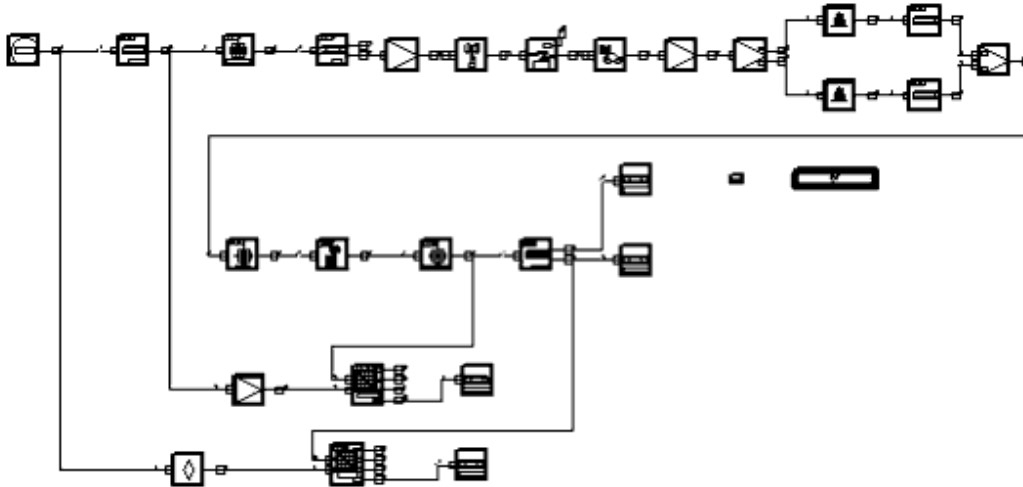

**Schematic of Traffic Channel/Full-rate Speech (TCH/FS)**

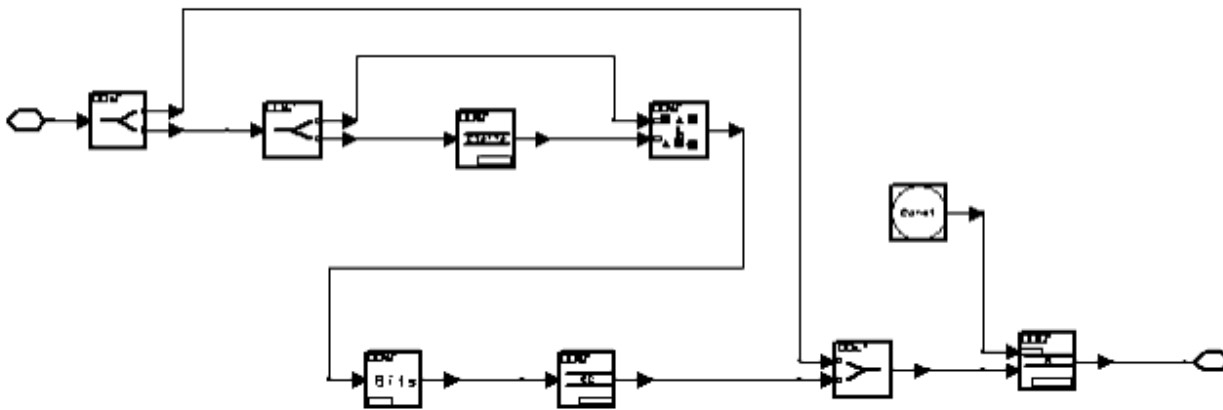

**Subnetwork of Channel Coder for TCH/FS**

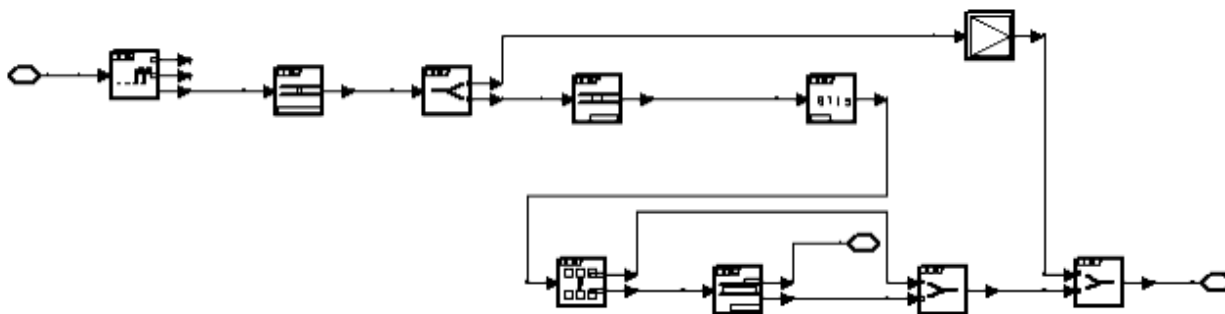

## Subnetwork of Channel Decoder for TCH/FS

### Specifications

Symbol	Specification	Simulation Type	Value	Unit
Pc	power per bit	ADS Ptolemy	1e-3	W
M	GMSK modulation sample rate	ADS Ptolemy	1	N/A
TSC	training sequence code	ADS Ptolemy	0	N/A
TStep	output time step for channel model	ADS Ptolemy	3.692/8	μsec

### Notes

- Sample rate is 4, 8, or 16 when M is 0, 1 or 2, respectively.
- TStep must be related to M, that is SampleRate=8 and TStep=3.69/SampleRate μsec.
- Since there are processing delays, the BER measurement with channel coding starts after first 260 bits output.

### Simulation Results

[Number of Error Bits of Data With and Without Channel Coding](#) shows the number of error bits of data with and without channel coding. The improvement of performance by using channel codec is significant.

To compare the BER performance of transmission with and without channel coding in 10 frame simulation, the variance of Gaussian noise is set to 1.0.

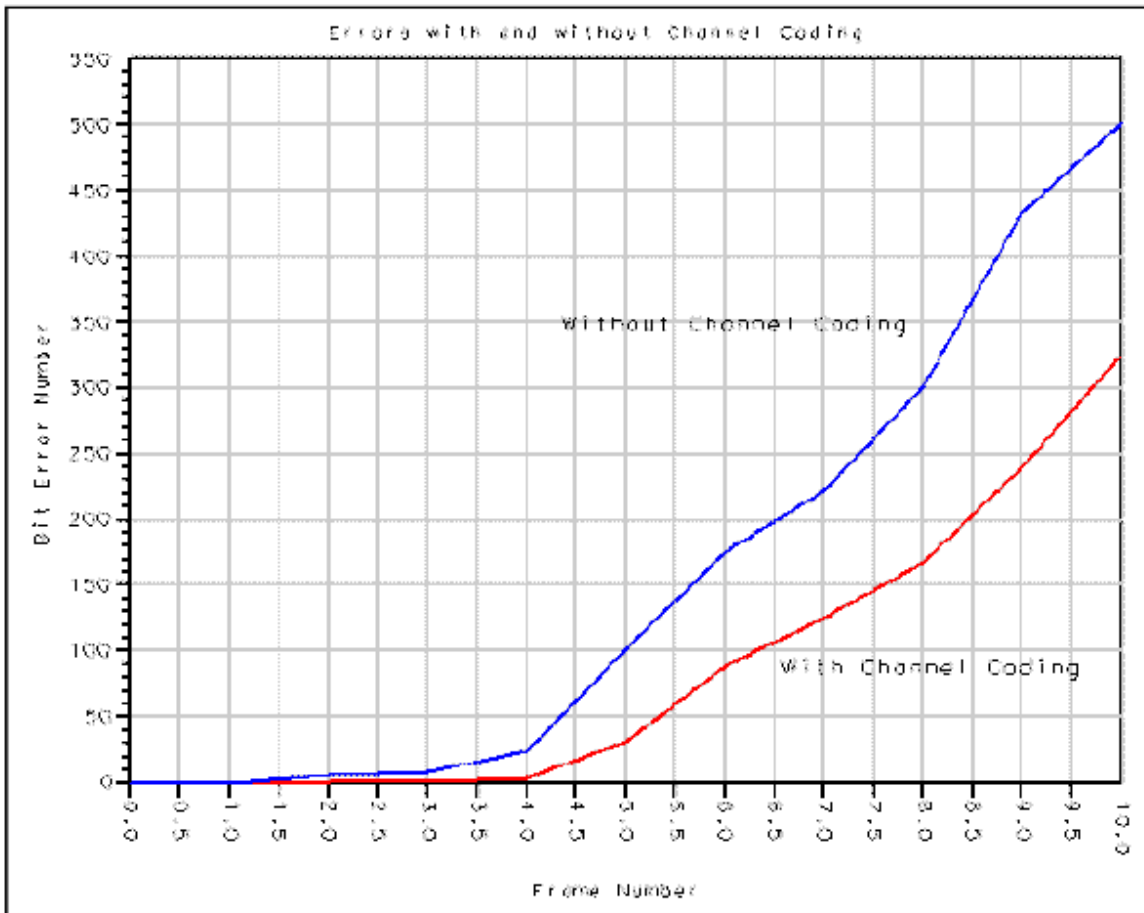

**Number of Error Bits of Data With and Without Channel Coding**

**Benchmark**

- Hardware Platform: Pentium Pro 200 MHz, 96 MB memory
- Software Platform: Windows NT 4.0 Workstation, Advanced Design System 1.1
- Data Points: 10 frames
- Simulation Time: approximately 1 minute

# Measurement Components for GSM Design Library

- *GSM BerFer* (gsm)
- *GSM ErrPatternDisplay* (gsm)

# GSM\_BerFer

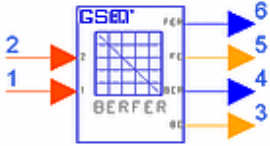

**Description:** Ber and Fer Performance

**Library:** GSM, Measurement

**Class:** SDFGSM\_BerFer

## Parameters

Name	Description	Default	Symbol	Unit	Type	Range
Start	frame from which measurement starts	DefaultNumericStart	F1		int	[0:inf]
Stop	frame at which measurement stops	DefaultNumericStop	F2		int	[F1:inf]
FrameLength	number of bits in a frame	1	N		int	[1:inf]

## Pin Inputs

Pin	Name	Description	Signal Type
1	in1	first expected or estimated sequence	anytype
2	in2	second expected or estimated sequence	anytype

## Pin Outputs

Pin	Name	Description	Signal Type
3	BE	sum of bit errors from start of simulation	int
4	BER	output bit error rate	real
5	FE	sum of frame errors from start of simulation	int
6	FER	output frame error rate	real

## Notes/Equations

1. This model is used to calculate system bit error rate (BER) and frame error rate (FER). One output token is produced for each N token consumed.
2. Implementation  
The Monte Carlo method is used to calculate the BER and FER of the system from the  $F1$  th frame to the  $F2$  th frame.

# GSM\_ErrPatternDisplay

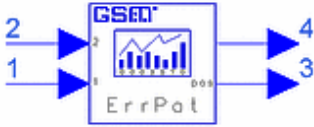

**Description:** Error Pattern Display Used in Equalization

**Library:** GSM, Measurement

**Class:** SDFGSM\_ErrPatternDisplay

## Pin Inputs

Pin	Name	Description	Signal Type
1	input1	first input data sequence to be compared	real
2	input2	second input data sequence to be compared	real

## Pin Outputs

Pin	Name	Description	Signal Type
3	pos	position of each bit in burst to be used in x-axis	real
4	output	error ratio of each bit in burst	real

## Notes/Equations

1. This model is used to display error distribution in a burst. 148 output tokens are produced for each 156 input tokens consumed.
2. Implementation  
This model compares the source bursts with the equalization results bit-by-bit, and accumulates bit error numbers for each bit position in a burst. The error distribution in bursts can be obtained by using the position of each bit of burst as x-axis. For every burst of 156 bits, only the first 148 bits are considered; the eight guard bits are ignored.



# Modem Components

- *GSM AQuarterBitAdd* (gsm)
- *GSM AQuarterBitRmv* (gsm)
- *GSM Carrier* (gsm)
- *GSM DifferDecoder* (gsm)
- *GSM DifferEncoder* (gsm)
- *GSM GMSKDemod* (gsm)
- *GSM GMSKMod* (gsm)
- *GSM MpyClock* (gsm)
- *GSM Rom* (gsm)

# GSM\_AQuarterBitAdd



**Description:** Add 0.25-Bit to 156-Bit Burst

**Library:** GSM, Modems

**Class:** SDFGSM\_AQuarterBitAdd

## Parameters

Name	Description	Default	Unit	Type	Range
SampleRate	number of samples in one bit interval: SampleRate 4, SampleRate 8, SampleRate 16	SampleRate 16		enum	

## Pin Inputs

Pin	Name	Description	Signal Type
1	st	modulated signal with a burst of 156 bits	complex
2	fi	carrier frequency	real

## Pin Outputs

Pin	Name	Description	Signal Type
3	sa	modulated signal with a burst of 156.25 bits	complex
4	fo	carrier frequency	real

## Notes/Equations

- This model is used to add  $0.25\text{bit} \times M$  points that are set from 0 to a burst of 156 bits of modulated signal in order to simulate a burst of 156.25 bits in a GSM system.

st: Input  $156 \times M$

fi: Input  $156 \times M$

sa: Output  $156.25 \times M$

fo: Output  $156.25 \times M$

- Implementation

[Implementation of GSM\\_AQuarterBitAdd](#) shows the implementation of the model.

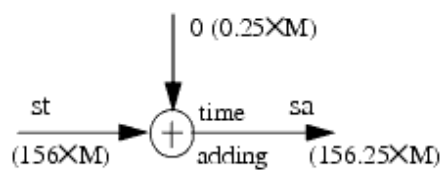

## Implementation of GSM\_AQuarterBitAdd

## References

1. European Telecommunications Standard Institute (ETSI), Rec. ETSI/GSM 05.01, *Physical layer on the radio path; General description*, version 5.0.0, May 1996.

# GSM\_AQuarterBitRmv



**Description:** Remove 0.25-Bit from 156.25-Bit Burst

**Library:** GSM, Modems

**Class:** SDFGSM\_AQuarterBitRmv

## Parameters

Name	Description	Default	Unit	Type	Range
SampleRate	number of samples in one bit interval: SampleRate 4, SampleRate 8, SampleRate 16	SampleRate 16		enum	

## Pin Inputs

Pin	Name	Description	Signal Type
1	st	modulated signal with a burst of 156.25 bits	complex
2	fi	carrier frequency	real

## Pin Outputs

Pin	Name	Description	Signal Type
3	so	modulated signal with a burst of 156 bits	complex
4	fo	carrier frequency	real

## Notes/Equations

- This model is used to remove  $0.25\text{-bit} \times M$  points in a burst of  $156.25\text{-bit} \times M$  points of modulated signal. It is the reverse process of GSM\_AQuarterBitAdd. After removal of the 0.25-bit, the signal will be sent to the demodulation model for demodulation.

st: Input  $156.25 \times M$

fi: Input  $156.25 \times M$

so: Output  $156 \times M$

fo: Output  $156 \times M$

- Implementation

[Implementation of GSM\\_AQuarterBitRmv](#) shows the implementation of the model.

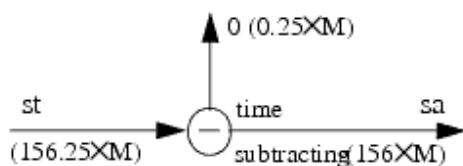

**Implementation of GSM\_AQuarterBitRmv**

**References**

1. European Telecommunications Standard Institute (ETSI), Rec. ETSI/GSM 05.01, *Physical layer on the radio path; General description*, version 5.0.0, May 1996.

# GSM\_Carrier



**Description:** Generation of Modulated Signal

**Library:** GSM, Modems

**Class:** SDFGSM\_Carrier

## Parameters

Name	Description	Default	Unit	Type	Range
Fc	carrier frequency	45e6	Hz	real	(0, ∞)
Pc	power per modulating bit	1e-3	W	real	(0, ∞)

## Pin Inputs

Pin	Name	Description	Signal Type
1	Ii	COS value of the modulated signal phase	real
2	Qi	SIN value of the modulated signal phase	real

## Pin Outputs

Pin	Name	Description	Signal Type
3	It	I branch of complex envelope of modulated signal	real
4	Qt	Q branch of complex envelope of modulated signal	real
5	fo	carrier frequency	real

## Notes/Equations

1. This model is used to generate modulated signal which is represented by complex envelope equivalent and carrier frequency.  
One token is consumed at each input pin; one token is produced at each output pin.

2. Implementation

The modulated signal is:

$$x_g(t) = \sqrt{2P_c} \cdot \cos(2\pi f_o t + \theta(t) + \theta_0)$$

where  $\theta_0$

is a random phase and is constant during one burst. In general, we set  $\theta_0 = 0$ .

$$\begin{aligned}
 x_g(t) &= \sqrt{2P_c} \cdot \cos(2\pi f_o t + \theta(t)) \\
 &= \sqrt{2P_c} \cdot \cos 2\pi f_o t \cdot \cos \theta(t) - \sqrt{2P_c} \cdot \sin 2\pi f_o t \cdot \sin \theta(t) \\
 &= It \cdot \cos 2\pi f_o t + Qt \cdot \sin 2\pi f_o t
 \end{aligned}$$

Then,  
where

$$It = \sqrt{2P_c} \cdot \cos \theta(t)$$

$$Qt = -\sqrt{2P_c} \cdot \sin \theta(t)$$

$$f_o = Fc1$$

## References

1. European Telecommunications Standard Institute (ETSI), Rec. ETSI/GSM 05.04, *European Digital Cellular Telecommunications System, Modulation*, version 4.0.3, Sept. 1994.

# GSM\_DifferDecoder



**Description:** Differential Decoder of Input Bits

**Library:** GSM, Modems

**Class:** SDFGSM\_DifferDecoder

## Pin Inputs

Pin	Name	Description	Signal Type
1	ak	input bits, taking the value of 1 or -1	int

## Pin Outputs

Pin	Name	Description	Signal Type
2	ck	differentially decoded bits, taking the value of 0 or 1	int

## Notes/Equations

1. This model is used to implement differential decoding of the input bits to match the differential encoding of a GMSK signal. The initial value of the first bit is set to 1, the same as differential encoding. One token is consumed at the input, one token is produced at the output.
2. Implementation

[GSM\\_DifferDecoder Implementation](#) shows the implementation of the model.

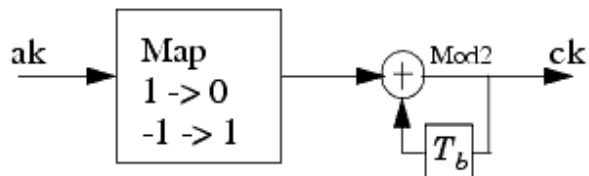

## GSM\_DifferDecoder Implementation

## References

1. European Telecommunications Standard Institute (ETSI), Rec. ETSI/GSM 05.04, *European Digital Cellular Telecommunications System, Modulation*, version 4.0.3, Sept. 1994.



# GSM\_DifferEncoder



**Description:** Differential Encoder of Input Bits

**Library:** GSM, Modems

**Class:** SDFGSM\_DifferEncoder

## Pin Inputs

Pin	Name	Description	Signal Type
1	dk	input bits, taking the value of 0 or 1	int

## Pin Outputs

Pin	Name	Description	Signal Type
2	ak	differentially encoded bits, taking the value of 1 or -1	int

## Notes/Equations

- This model is used to implement differential encoding of the input bits, which is required in GSM standard to generate GMSK signal. According to the standard GSM 05.04, the initial value of the first bit is assigned to 1. One token is consumed at the input, one token is produced at the output.
- Implementation  
[GSM\\_DifferEncoder Implementation](#) shows the implementation of the model.

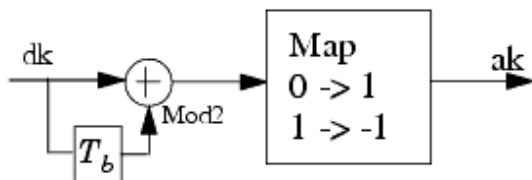

## GSM\_DifferEncoder Implementation

## References

- European Telecommunications Standard Institute (ETSI), Rec. ETSI/GSM 05.04, *European Digital Cellular Telecommunications System, Modulation*, version 4.0.3, Sept. 1994.

# GSM\_GMSKDemod



**Description:** Demodulation of GMSK Modulated Signal

**Library:** Testing (for development use only)

**Class:** SDFGSM\_GMSKDemod

## Pin Inputs

Pin	Name	Description	Signal Type
1	input	GMSK modulated data	complex

## Pin Outputs

Pin	Name	Description	Signal Type
2	ck	differentially decoded bits, taking the value of 0 or 1	int

## Notes/Equations

1. This subnetwork is used to demodulate the GMSK modulated signal to recover the original bit stream.
2. Implementation  
Two branches of modulated signal I and Q go through two quantizers to determine 1 (when  $>0$ ) or  $-1$  (when  $<0$ ). After the two quantized signals are module-2 added, the signal multiplies the reverse clock signal and is demodulated. Refer to [GSM\\_GMSKDemod Block Diagram](#).

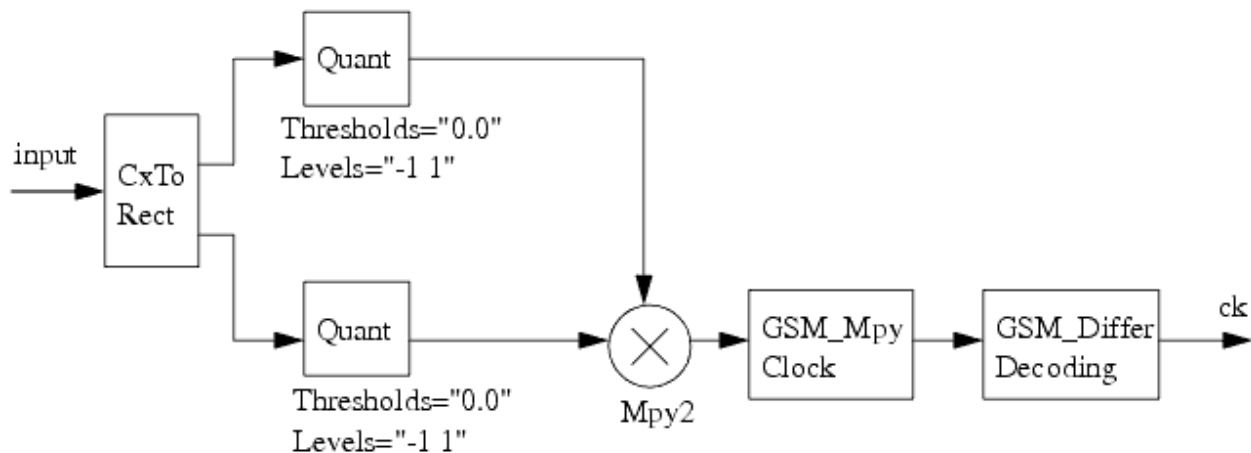

**GSM\_GMSKDemod Block Diagram**

## References

1. European Telecommunications Standard Institute (ETSI), Rec. ETSI/GSM 05.04, *European Digital Cellular Telecommunications System, Modulation*, version 4.0.3, Sept. 1994.

# GSM\_GMSKMod



**Description:** Generation of GMSK Modulated Signal

**Library:** GSM, Modems

**Class:** SDFGSM\_GMSKMod

## Parameters

Name	Description	Default	Unit	Type	Range
SampleRate	number of samples in one bit interval: SampleRate 4, SampleRate 8, SampleRate 16	SampleRate 16		enum	
Fc	carrier frequency	45e6	Hz	real	(0, $\infty$ )
Pc	power per modulating bit	1e-3	W	real	(0, $\infty$ )

## Pin Inputs

Pin	Name	Description	Signal Type
1	dk	input bits, value of 0 or 1	int

## Pin Outputs

Pin	Name	Description	Signal Type
2	output	complex envelope of modulated signal	complex
3	fo	carrier frequency	real

## Notes/Equations

1. This subnetwork is used to generate a GMSK modulated signal that is represented by complex envelope equivalent and carrier frequency.
2. Implementation  
The process of GMSK modulation is a differential encoding that adds MSK modulation. GSM\_DifferEncoder implements differential encoding of input bit stream; GSM\_Rom and GSM\_Carrier implement MSK modulation. To increase modulation speed, a *table-lookup* is used. Refer to [GSM\\_GMSKMod Block Diagram](#).

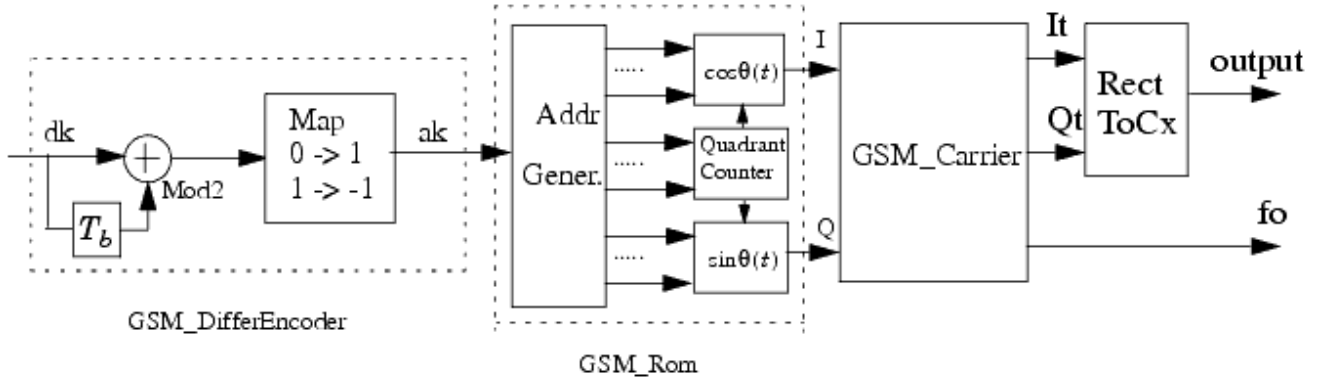

**GSM\_GMSKMod Block Diagram**

**References**

1. European Telecommunications Standard Institute (ETSI), Rec. ETSI/GSM 05.04, *European Digital Cellular Telecommunications System, Modulation*, version 4.0.3, Sept. 1994.
2. European Telecommunications Standard Institute (ETSI), Rec. ETSI/GSM 05.05, *Digital Cellular Telecommunications System, Radio Transmission And Reception*, version 5.2.0, July 1996

# GSM\_MpyClock



**Description:** Input and Alternate 1 and -1 Multiplier

**Library:** GSM, Modems

**Class:** SDFGSM\_MpyClock

## Pin Inputs

Pin	Name	Description	Signal Type
1	ft	input bits	int

## Pin Outputs

Pin	Name	Description	Signal Type
2	st	product of input bits and clock signal	int

## Notes/Equations

1. This model is used to multiply input bits with alternate 1 and  $-1$ . Two tokens are consumed at the input, two tokens are produced at the output.
2. Implementation  
The model implements input signal ft by multiplying it with a reverse clock signal. Each firing, ft inputs 2 tokens, the first is to multiply 1, the second is to multiply  $-1$ . Refer to [GSM\\_MpyClock Implementation](#).

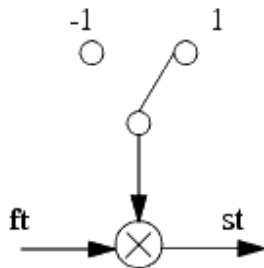

## GSM\_MpyClock Implementation

# GSM\_Rom



**Description:** Generation of I and Q Branches of Modulated Signal

**Library:** GSM, Modems

**Class:** SDFGSM\_Rom

## Parameters

Name	Description	Default	Unit	Type	Range
SampleRate	number of samples in one bit interval: SampleRate 4, SampleRate 8, SampleRate 16	SampleRate 16		enum	

## Pin Inputs

Pin	Name	Description	Signal Type
1	ak	bit stream; value is 1 or -1	int

## Pin Outputs

Pin	Name	Description	Signal Type
2	I	COS value of phase modulated signal	real
3	Q	SIN value of phase modulated signal	real

## Notes/Equations

1. This model is used to generate I and Q branches of the modulated signal [1]. 156 tokens are consumed at the input, 156×M tokens are produced at each output pin.
2. Implementation

[GSM\\_Rom Block Diagram](#) is a block diagram of this model. The outputs are:

$$I = \cos \theta(t) = \cos(m(t) + p')$$

$$Q = \sin \theta(t) = \sin(m(t) + p')$$

with

$$m(t) = \frac{\pi}{2T_b} \cdot \sum_{n=k-2}^{k+2} \left[ a_n \int_{-\infty}^{t-nT_b-\frac{T_b}{2}} g(u) du \right]$$

and

$$p' = \frac{\pi}{2} \sum_{n=0}^{k-5} a_n$$

where

$a_n$  is the input bit (take the value  $\pm 1$ ),  $T_b$

is the bit interval,  $k$  is the current bit index and  $g(u)$  is the response of a Gaussian filter to a rectangular pulse.

The COS and SIN value of  $m(t)$

are pre-calculated and saved in two tables. In each firing, the tables are searched according to the address formed by the five consecutive input bits. The initial values

of bits  $a_0, a_1, a_2, a_3, a_4$

are set to 1, so the initial address is 00000 (there is data mapping from input data value to address, that is from 1,-1 to 0,1).

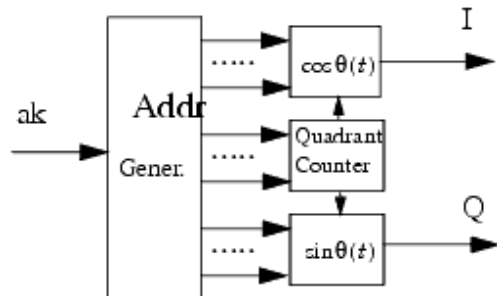

**GSM\_Rom Block Diagram**

**References**

1. European Telecommunications Standard Institute (ETSI), Rec. ETSI/GSM 05.05, *Digital Cellular Telecommunications System, Radio Transmission And Reception*, version 5.2.0, July 1996.



# Speech Codec Components

- *GSM APCM Quantizer* (gsm)
- *GSM Autocorrelation* (gsm)
- *GSM CodeLAR* (gsm)
- *GSM DecodeLAR* (gsm)
- *GSM Deemphasis* (gsm)
- *GSM Deframing* (gsm)
- *GSM Framing* (gsm)
- *GSM Interpolation* (gsm)
- *GSM InverseAPCM* (gsm)
- *GSM LARToRefCoe* (gsm)
- *GSM LogAreaRatio* (gsm)
- *GSM LongTermAnalysis* (gsm)
- *GSM LongTermSynthesis* (gsm)
- *GSM LTP Parameter* (gsm)
- *GSM OffsetCompensation* (gsm)
- *GSM Postprocessing* (gsm)
- *GSM Preemphasis* (gsm)
- *GSM ReadFile* (gsm)
- *GSM RPE GridPosition* (gsm)
- *GSM RPE GridSelection* (gsm)
- *GSM ScaleInput* (gsm)
- *GSM Schur* (gsm)
- *GSM ShortTermAnalysis* (gsm)
- *GSM ShortTermPredict* (gsm)
- *GSM ShortTermSynthesis* (gsm)
- *GSM SpeechDecoder* (gsm)
- *GSM SpeechEncoder* (gsm)
- *GSM WeightingFilter* (gsm)
- *GSM WriteFile* (gsm)

# GSM\_APCM\_Quantizer



**Description:** APCM Quantization.

**Library:** GSM, Speech Coding

**Class:** SDFGSM\_APCM\_Quantizer

## Parameters

Name	Description	Default	Unit	Type	Range
BlockSize	number of input and output samples.	13		int	[1, ∞)

## Pin Inputs

Pin	Name	Description	Signal Type
1	input	Xm, selected RPE sequence with maximum energy.	fix

## Pin Outputs

Pin	Name	Description	Signal Type
2	Xmc	quantized Xm.	fix
3	Xmaxc	coded version of the maximum of Xm.	fix

## Notes/Equations

- This model is used to APCM quantize the selected RPE sequence. BlockSize specifies the number of input tokens consumed and output tokens produced at Xmc. Xmaxc produces one token each firing.
- Implementation  
Normalize and quantize the selected RPE sequence  $XM(i)$  and then get Xmaxc. For each RPE sequence consisting of a set of 13 samples  $XM(i)$ , the maximum Xmax of the absolute values  $XM(i)$  is selected and quantized logarithmically with 6 bits Xmaxc (as given in table 3.5 of GSM 06.10 section 3.1.20).  
For normalization, the 13 samples are divided by the decoded version  $X'_{max}$  of the

$$X'(i) = XM(i)/X'_{max} \quad ;i=0,,12$$

block maximum:

The normalized samples  $X'(i)$  are quantized uniformly with three bits to obtain  $XM_c(i)$ .

## References

- European Telecommunications Standard Institute (ETSI), Rec. ETSI/GSM 06.10, *Full*

*Rate Speech Transcoding*, version 4.0.2, Sept. 1994.

2. GSM\_InverseAPCM model.

# GSM\_Autocorrelation

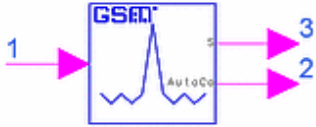

**Description:** Autocorrelation Function Values

**Library:** GSM, Speech Coding

**Class:** SDFGSM\_Autocorrelation

## Parameters

Name	Description	Default	Unit	Type	Range
Precision	input and output precision.	16.0		precision	[2.0, ∞)
NoInput	number of input samples to average.	160		int	(0, ∞)
NoLags	number of autocorrelation lags to output.	9		int	(0, ∞)

## Pin Inputs

Pin	Name	Description	Signal Type
1	input	emphasised signal $S[k]$ .	fix

## Pin Outputs

Pin	Name	Description	Signal Type
2	AutoCo	values of autocorrelation function.	fix
3	Sout	input signal after truncating last scalauto (internal variable) MSB	fix

## Notes/Equations

1. This model is used to calculate the autocorrelation array  $L\_ACF[k]$ . Each firing, NoInput tokens are consumed at input; NoLags tokens at AutoCo and NoInput tokens at Sout are produced.
2. Implementation

$$ACF(k) = \sum_{i=k}^{159} S(i) \times S(i-k)$$

$$k = 0, 1, \dots, 8$$

## References

1. European Telecommunications Standard Institute (ETSI), Rec. ETSI/GSM 06.10, *Full Rate Speech Transcoding*, version 4.0.2, Sept. 1994.

# GSM\_CodeLAR



**Description:** LAR Coder

**Library:** GSM, Speech Coding

**Class:** SDFGSM\_CodeLAR

## Pin Inputs

Pin	Name	Description	Signal Type
1	input	LAR(i), i=0,...,7, log-area ratios.	fix

## Pin Outputs

Pin	Name	Description	Signal Type
2	output	LARc(i), i=0,...,7 ,denoting the quantized and integer coded version of LAR(i).	fix

## Notes/Equations

1. This model is used to quantize and code log-area ratios (LAR).  
Each firing, 8 tokens are consumed at input; eight tokens are produced at output.

2. Implementation

$$LARc(i) = Nint\{A(i) \times LAR(i) + B(i)\}$$

with

$$Nint\{z\} = int\{z + sign\{z\} \times 0.5\}$$

Coefficients  $A(i)$ ,  $B(i)$  and different extreme values of  $LARc(i)$  for each coefficient  $LAR(i)$  are given in [Quantization of Log-Area Ratio LAR\(i\)](#).

### Quantization of Log-Area Ratio LAR(i)

LAR No i	A(i)	B(i)	Minimum LARc(i)	Maximum LARc(i)
1	20.000	0.000	-32	+31
2	20.000	0.000	-32	+31
3	20.000	4.000	-16	+15
4	20.000	-5.000	-16	+15
5	13.637	0.184	-8	+7
6	15.000	-3.500	-8	+7
7	8.334	-0.666	-4	+3
8	8.824	-2.235	-4	+3

## References

1. European Telecommunications Standard Institute (ETSI), Rec. ETSI/GSM 06.10, *Full Rate Speech Transcoding*, version 4.0.2, Sept. 1994

# GSM\_DecodeLAR



**Description:** LAR Decoder

**Library:** GSM, Speech Coding

**Class:** SDFGSM\_DecodeLAR

## Pin Inputs

Pin	Name	Description	Signal Type
1	input	LARc(i), i=0,...,7, quantized and integer coded version of LAR(i).	fix

## Pin Outputs

Pin	Name	Description	Signal Type
2	output	LAR''(i), i=0,...,7, decoded LARc(i).	fix

## Notes/Equations

- This model is used to decode LARc. Input LARc(i), i = 0, ... , 7, are coded in 6, 6, 5, 5, 4, 4, 3, 3 bits, respectively; the input tokens cannot exceed their extreme values. Each firing, eight tokens are consumed at input, and eight tokens are produced at output.
- Implementation

$$LAR''(i) = (LARc(i) - B(i)) / A(i)$$

Coefficients  $A(i)$ ,  $B(i)$  and different extreme values of  $LARc(i)$  for each coefficient  $LAR(i)$  are given in *Quantization of Log-Area Ratio LAR(i)*.

LAR No i	A(i)	B(i)	Minimum LARc(i)	Maximum LARc(i)
1	20.000	0.000	-32	+31
2	20.000	0.000	-32	+31
3	20.000	4.000	-16	+15
4	20.000	-5.000	-16	+15
5	13.637	0.184	-8	+7
6	15.000	-3.500	-8	+7
7	8.334	-0.666	-4	+3
8	8.824	-2.235	-4	+3

## References

1. European Telecommunications Standard Institute (ETSI), Rec. ETSI/GSM 06.10, Full Rate Speech Transcoding, version 4.0.2, Sept. 1994.
2. GSM\_CodeLAR model.



# GSM\_Deemphasis



**Description:** De-emphasis Filter

**Library:** GSM, Speech Coding

**Class:** SDFGSM\_Deemphasis

## Parameters

Name	Description	Default	Unit	Type	Range
Precision	input and output precision.	16.0		precision	[2.0, ∞)
BlockSize	number of samples to read and output per frame.	160		int	(0, ∞)
Beta	emphasis coefficient	28180		int	(0:inf)

## Pin Inputs

Pin	Name	Description	Signal Type
1	input	reconstructed speech signal $S_r(k)$	fix

## Pin Outputs

Pin	Name	Description	Signal Type
2	output	de-emphasized speech signal $S_{ro}(k)$	fix

## Notes/Equations

- This model is used to de-emphasize the high-frequency part of the input signal  $S_r(k)$ .  
BlockSize specifies the number of input and output tokens each firing.
- Implementation  

$$S_{ro}(k) = S_r(k) + \beta \times S_{ro}(k-1)$$
 where  $\beta$  is the emphasis coefficient.

## References

- European Telecommunications Standard Institute (ETSI), Rec. ETSI/GSM 06.10, *Full Rate Speech Transcoding*, version 4.0.2, Sept. 1994
- GSM\_Preemphasis model.

# GSM\_Deframing

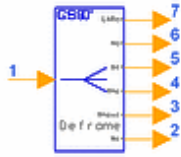

**Description:** Unpacking Frame.

**Library:** GSM, Speech Coding

**Class:** SDFGSM\_Deframing

## Pin Inputs

Pin	Name	Description	Signal Type
1	input	frame data in bits, one bit per integer.	int

## Pin Outputs

Pin	Name	Description	Signal Type
2	Mcr	received Mcr, denoting which one has maximum energy.	int
3	Xmaxcr	received the maximum of quantized Xm[..]	int
4	Xmcr	received Xmc(i), i=0,...,12, quantized Xm	int
5	bcr	received bc(j), j=0,...,3, coded gain factor	int
6	Ncr	received Nc, coded correlation lag.	int
7	LARcr	received LARc(i)	int

## Notes/Equations

- This model unpacks the incoming serial bit speech packet into several parameters for decoding. This is an inverse transformation of GSM\_Framing. Each firing, 260 tokens are consumed at the input. Output tokens are listed in the following table.

Output Pin	Output Tokens
Mcr	4
Xmaxcr	4
Xmcr	13 × 4
bcr	4
Ncr	4
LARcr	8

## References

- European Telecommunications Standard Institute (ETSI), Rec. ETSI/GSM 06.10, *Full*

2. GSM\_Framing model.

# GSM\_Framing

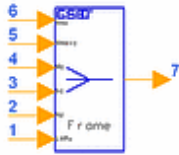

**Description:** Form 260-bit Frame According to GSM 06.10 Bit Map

**Library:** GSM, Speech Coding

**Class:** SDFGSM\_Framing

## Pin Inputs

Pin	Name	Description	Signal Type
1	LARc	LARc(i), $i=1,\dots,8$ , denoting the quantized and integer coded version of LAR(i).	int
2	Nc	$Nc_j$ , $j=0,\dots,3$ , coded correlation lag.	int
3	bc	$bc_j$ , $j=0,\dots,3$ , coded gain factor.	int
4	Mc	Mc, denoting which one has maximum energy.	int
5	Xmaxc	maximum of quantized $X_m[..]$ .	int
6	Xmc	$Xmc(i)$ , $i=0,\dots,12$ , quantized $X_m$ .	int

## Pin Outputs

Pin	Name	Description	Signal Type
7	output	frame data in bits, one bit per integer.	int

## Notes/Equations

This model is used to form a speech frame. It packs coded parameters LARc, Nc, bc, Mc, Xmaxc, Xmc into serial bit stream. 260 tokens are output; input tokens are listed in the following table. The details about sequence of output bits b1 to b260 and bit allocation for each parameter are specified in GSM 06.10 section 1.7.

Input Pin	Input Tokens
Mcr	4
Xmaxcr	4
Xmcr	$13 \times 4$
bcr	4
Ncr	4
LARcr	8

## References

1. European Telecommunications Standard Institute (ETSI), Rec. ETSI/GSM 06.10, *Full*

2. GSM\_Deframing model.

# GSM\_Interpolation



**Description:** Linear Interpolation of Log-Area Ratios.

**Library:** GSM, Speech Coding

**Class:** SDFGSM\_Interpolation

## Parameters

Name	Description	Default	Unit	Type	Range
Precision	input and output precision.	16.0		precision	[2.0, $\infty$ )
NoInput	number of input samples.	8		int	[1, $\infty$ )

## Pin Inputs

Pin	Name	Description	Signal Type
1	input	$LAR''(i)$ , $i=0,\dots,7$ , decoded $LARc(i)$	fix

## Pin Outputs

Pin	Name	Description	Signal Type
2	output	$LAR'(i)$ , $i=0,\dots,7$ , interpolation of log-area ratios.	fix

## Notes/Equations

1. This model is used to interpolate  $LAR''[i]$  to determine  $LAR'[i]$ .  
NoInput specifies the number of input and output tokens each firing.
2. Implementation  
Within each frame of 160 analyzed speech samples the short-term analysis and synthesis filters operate with four different sets of coefficients, derived from the previous set of decoded  $LAR''(j-1)$  and the actual set of decoded  $LAR''(j)$ . To provide four sets of coefficients, the output rate is four times the input rate. For each set of inputs, four sets of outputs are produced using different interpolation values, as listed in [Interpolation of LAR Parameters \( \$j = \text{actual segment}\$ \)](#).

[Interpolation of LAR Parameters \( \$j = \text{actual segment}\$ \)](#)

<b>k</b>	$LAR'_j(i)$
0...12	$0.75 \times LAR''_{j-1}(i) + 0.25 \times LAR''_j(i)$
13...26	$0.50 \times LAR''_{j-1}(i) + 0.50 \times LAR''_j(i)$
27...39	$0.25 \times LAR''_{j-1}(i) + 0.75 \times LAR''_j(i)$
40...159	$LAR''_j(i)$

## References

1. European Telecommunications Standard Institute (ETSI), Rec. ETSI/GSM 06.10, *Full Rate Speech Transcoding*, version 4.0.2, Sept. 1994.

# GSM\_InverseAPCM



**Description:** APCM Decode

**Library:** GSM, Speech Coding

**Class:** SDFGSM\_InverseAPCM

## Parameters

Name	Description	Default	Unit	Type	Range
BlockSize	number of input and output samples.	13		int	[1, ∞)

## Pin Inputs

Pin	Name	Description	Signal Type
1	Xmc	quantized $X_m$	fix
2	Xmaxc	coded version of the maximum of $X_m$	fix

## Pin Outputs

Pin	Name	Description	Signal Type
3	output	reconstructed $X'_m(i)$ .	fix

## Notes/Equations

1. This model is used to decode the coded RPE sequence. BlockSize specifies the number of tokens consumed at  $X_{mc}$  and produced at output.  $X_{maxc}$  consumes one token each firing.
2. Implementation

This is an inverse transformation of GSM\_APCM\_Quantizer. After decoding  $X'_{maxc}$  of  $X_{Mc}(i)$ , a denormalizing process is used to obtain the reconstructed sub-sequence  $X'_M(i)$ .

## References

1. European Telecommunications Standard Institute (ETSI), Rec. ETSI/GSM 06.10, *Full Rate Speech Transcoding*, version 4.0.2, Sept. 1994.



## GSM\_LARToRefCoe



**Description:** Transform Log-Area Ratios to Reflection Coefficients

**Library:** GSM, Speech Coding

**Class:** SDFGSM\_LARToRefCoe

### Parameters

Name	Description	Default	Unit	Type	Range
BlockSize	number of input and output samples.	32		int	[1, ∞)

### Pin Inputs

Pin	Name	Description	Signal Type
1	input	LAR'(i), i=1,...,8, interpolation of log-area ratios.	fix

### Pin Outputs

Pin	Name	Description	Signal Type
2	output	r'(i), i=1,...,8, coded reflection coefficients.	fix

### Notes/Equations

1. This model decodes interpolated log-area ratios to reconstruct reflection coefficients (this is the inverse transformation of GSM\_LogAreaRatio). BlockSize specifies the number of input and output tokens each firing.
2. Implementation  
The following equation gives the inverse transformation.

$$LAR'(i); |LAR'(i)| < 0.675$$

$$r'(i) = \text{sign}[LAR'(i)] \times [0.500 \times |LAR'(i)| + 0.337500]; 0.675 \leq |LAR'(i)| < 1.225$$

$$\text{sign}[LAR'(i)] \times [0.125 \times |LAR'(i)| + 0.796875]; 1.225 \leq |LAR'(i)| \leq 1.625$$

### References

1. European Telecommunications Standard Institute (ETSI), Rec. ETSI/GSM 06.10, *Full Rate Speech Transcoding*, version 4.0.2, Sept. 1994.

# GSM\_LogAreaRatio



**Description:** Transform Reflection Coefficients to Log-Area Ratio

**Library:** GSM, Speech Coding

**Class:** SDFGSM\_LogAreaRatio

## Parameters

Name	Description	Default	Unit	Type	Range
NoInput	number of input and output samples.	8		int	[1, ∞)

## Pin Inputs

Pin	Name	Description	Signal Type
1	input	$r(i)$ , $i=1, \dots, 8$ , reflection coefficients.	fix

## Pin Outputs

Pin	Name	Description	Signal Type
2	output	$LAR(i)$ , $i=0, \dots, 7$ , log-area ratio.	fix

## Notes/Equations

1. This model is used to transform reflection coefficients into log-area ratio. NoInput specifies the number of input and output tokens each firing.
2.  $LAR(i)$  can be expressed as:

$$\text{Logarea}(i) = \log(1 + r(i)) / (1 - r(i))$$

This segmented approximation is used:

$$r(i); (|r(i)| < 0.675)$$

$$LAR(i) = \text{sign}[r(i)] \times [2 \times |r(i)| - 0.675]; 0.675 \leq |r(i)| < 0.950$$

$$\text{sign}[r(i)] \times [8 \times |r(i)| - 6.375]; 0.950 \leq |r(i)| \leq 1.000$$

The following scaling for  $r[.]$  and  $LAR[.]$  has been used:

$r[.] = \text{integer}(\text{real}_r[.] * 32768)$ ; with  $-1 \leq \text{real}_r < 1$   $LAR[.] = \text{integer}(\text{real\_LAR}[.] * 16384)$ ; with  $-1.625 \leq \text{real\_LAR}[.] \leq 1.625$ .

## References

1. European Telecommunications Standard Institute (ETSI), Rec. ETSI/GSM 06.10, *Full Rate Speech Transcoding*, version 4.0.2, Sept. 1994.
2. GSM\_LARToRefCoe model.

# GSM\_LongTermAnalysis



**Description:** Long-Term Residual Signal Generator.

**Library:** GSM, Speech Coding

**Class:** SDFGSM\_LongTermAnalysis

## Parameters

Name	Description	Default	Unit	Type	Range
Precision	input and output precision.	16.0		precision	[2.0, ∞)
BlockSize	number of input and output samples per sub-frame.	40		int	[1, ∞)

## Pin Inputs

Pin	Name	Description	Signal Type
1	est	$d''(k)$ , estimation of the short-term residual signal.	fix
2	res	$d(k)$ , short-term residual signal.	fix

## Pin Outputs

Pin	Name	Description	Signal Type
3	output	$e(k)$ , long-term residual signal.	fix

## Notes/Equations

1. This model is used to generate long-term residual signal. BlockSize specifies the number of input and output tokens each firing.
2. Implementation  
The short-term residual signal  $d(k)$  is processed by sub-segments of BlockSize (default=40) samples. From each of the four sub-segments of short-term residual  $d(k)$ , an estimate  $d''(k)$  of the signal is subtracted to generate the long-term residual signal  $e(k)$ .

$$e(k_j + k) = d(k_j + k) - d''(k_j + k); \begin{cases} j = 0, \dots, 3 \\ k = 0, \dots, 39 \\ k_j = k_0 + j \times 40 \end{cases}$$

## References

1. European Telecommunications Standard Institute (ETSI), Rec. ETSI/GSM 06.10, *Full*

2. GSM\_LongTermSynthesis model.

# GSM\_LongTermSynthesis



**Description:** Reconstructed Long-Term Residual Signal

**Library:** GSM, Speech Coding

**Class:** SDFGSM\_LongTermSynthesis

## Parameters

Name	Description	Default	Unit	Type	Range
Precision	input and output precision.	16.0		precision	[2.0, ∞)
BlockSize	number of input and output samples per sub-frame.	40		int	[1, ∞)

## Pin Inputs

Pin	Name	Description	Signal Type
1	est	$d''(k)$ , estimate of short-term residual signal.	fix
2	recons	$e'(k)$ , reconstructed long-term residual signal.	fix

## Pin Outputs

Pin	Name	Description	Signal Type
3	output	$d'(k)$ , reconstructed short-term residual samples.	fix

## Notes/Equations

- This model is used to reconstruct a short-term residual signal. This is an inverse transformation of GSM\_LongTermAnalysis. BlockSize (default=40) specifies the number of input and output tokens each firing.
- Implementation  
This model adds the reconstructed long-term residual signal  $e'[0..39]$  to the estimated signal  $d''[0..39]$  from the long-term analysis filter to calculate the reconstructed short-term residual signal  $d'[0..39]$  (for next sub-frame).

$$d'(k_j + k) = e'(k_j + k) + d''(k_j + k); \begin{pmatrix} j = 0, \dots, 3 \\ k = 0, \dots, 39 \\ k_j = k_0 + j \times 40 \end{pmatrix}$$

## References

1. European Telecommunications Standard Institute (ETSI), Rec. ETSI/GSM 06.10, *Full Rate Speech Transcoding*, version 4.0.2, Sept. 1994.
2. GSM\_LongTermAnalysis model.

# GSM\_LTP\_Parameter



**Description:** Calculate Long-Term Predict Parameters.

**Library:** GSM, Speech Coding

**Class:** SDFGSM\_LTP\_Parameter

## Parameters

Name	Description	Default	Unit	Type	Range
InputPrecision	input precision.	16.0		precision	[2.0, ∞)
BlockSize	number of input and output per sub-frame.	40		int	[1, ∞)

## Pin Inputs

Pin	Name	Description	Signal Type
1	sht	d(k), short-term residual signal.	fix
2	recons	d'(k), reconstructed short-term residual signal.	fix

## Pin Outputs

Pin	Name	Description	Signal Type
3	LTPgn	gain factor.	fix
4	LTPlag	correlation lag.	fix

## Notes/Equations

- This model is used to calculate long-term predict (LTP) parameters. BlockSize (default=40) specifies the number of sht and recons tokens each firing. The number of LTPgn and LTPlag tokens are fixed to 1.
- Implementation
  - Divide each 20 msec frame into four subsegments.
  - Calculate a long-term correlation lag  $N_j$  and an associated gain factor  $b_j$ ,  $j = 0, \dots, 3$  for four sub-segments.
  - Encode LTP lags  $N_j$ .
  - Encode LTP gains  $b_j$ .

## References

1. European Telecommunications Standard Institute (ETSI), Rec. ETSI/GSM 06.10, *Full Rate Speech Transcoding*, version 4.0.2, Sept. 1994.
2. GSM\_ShortTermPredict model.



# GSM\_OffsetCompensation



**Description:** Offset Compensation  
**Library:** GSM, Speech Coding  
**Class:** SDFGSM\_OffsetCompensation

## Parameters

Name	Description	Default	Unit	Type	Range
Precision	input and output precision.	16.0		precision	[2.0, ∞)
BlockSize	number of samples to read and output per frame.	160		int	(0, ∞)
Alpha	offset coefficient	32735		int	(0, ∞) †

†  $\text{Alpha} = 2^{\text{Precision.intb()} - 1}$ , where  $\text{Precision.intb()}$  is the integer part of Precision

## Pin Inputs

Pin	Name	Description	Signal Type
1	input	scaled speech signal $S_o$ .	fix

## Pin Outputs

Pin	Name	Description	Signal Type
2	output	offset free signal $S_{of}$	fix

## Notes/Equations

- This model is used to remove the offset of the input signal. BlockSize (default=160) specifies the number of input and output tokens each firing.
- Implementation  
This component implements a highpass filter and requires extended arithmetic for the recursive part of the filter (refer to 4.2.2 in GSM 06.10 for details).

$$S_{of}(k) = S_o(k) - S_o(k-1) + \alpha \times S_{of}(k-1)$$

$$\alpha = 32735 \times 2^{-15}$$

## References

1. European Telecommunications Standard Institute (ETSI), Rec. ETSI/GSM 06.10, *Full Rate Speech Transcoding*, version 4.0.2, Sept. 1994.

# GSM\_Postprocessing



**Description:** Post Processing.

**Library:** GSM, Speech Coding

**Class:** SDFGSM\_Postprocessing

## Parameters

Name	Description	Default	Unit	Type	Range
Precision	input and output precision.	16.0		precision	[2.0, $\infty$ )
BlockSize	number of samples to read and output per frame.	160		int	(0, $\infty$ )

## Pin Inputs

Pin	Name	Description	Signal Type
1	input	reconstructed speech signal.	fix

## Pin Outputs

Pin	Name	Description	Signal Type
2	output	reconstructed speech signal after postprocessing.	fix

## Notes/Equations

- This model is used to upscale reconstructed uniform PCM 13-bit stream. BlockSize (default 160) specifies the number of input and output tokens each firing.
- Implementation
  - Upscale the input signal.
  - Truncate the most right three bits of the upscaled signal. The output has the following format:  
s.v.v.v.v.v.v.v.v.v.v.v.v.v.v.v.x.x (twos complement format)  
where s is the sign bit, v is a valid bit, and x means don't care.

## References

- European Telecommunications Standard Institute (ETSI), Rec. ETSI/GSM 06.10, *Full Rate Speech Transcoding*, version 4.0.2, Sept. 1994.

# GSM\_Preemphasis

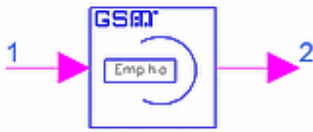

**Description:** High-Frequency Emphasize

**Library:** GSM, Speech Coding

**Class:** SDFGSM\_Preemphasis

## Parameters

Name	Description	Default	Unit	Type	Range
Precision	input and output precision.	16.0		precision	[2.0, ∞)
BlockSize	number of samples to read and output per frame.	160		int	(0, ∞)
Beta	emphasis coefficient.	28180		int	(0, ∞)

## Pin Inputs

Pin	Name	Description	Signal Type
1	input	offset free signal $S_{of}(k)$ .	fix

## Pin Outputs

Pin	Name	Description	Signal Type
2	output	emphasized signal $S(k)$ .	fix

## Notes/Equations

- This model is used to emphasize the high-frequency part of the input signal  $S_{of}(k)$ . BlockSize (default=160) specifies the number of input and output tokens each firing.
- Implementation  
The emphasizing processing is performed according to:

$$S(k) = S_{of}(k) - \beta \times S_{of}(k-1)$$

$$\beta = 28180 \times 2^{-15}$$

## References

- European Telecommunications Standard Institute (ETSI), Rec. ETSI/GSM 06.10, *Full Rate Speech Transcoding*, version 4.0.2, Sept. 1994.
- GSM\_Deemphasis model.

# GSM\_ReadFile



**Description:** 16-bit PCM Data Source

**Library:** GSM, Speech Coding

**Class:** SDFGSM\_ReadFile

## Parameters

Name	Description	Default	Unit	Type	Range
FileName	input wav file name.	pcm.wav		filename	
OutputType	type of reading file: periodic or non_periodic: periodic, non_periodic	non_periodic		enum	

## Pin Outputs

Pin	Name	Description	Signal Type
1	output	PCM data.	int

## Notes/Equations

1. This model provides a PCM data source. Data is read from a 16-bit PCM wav file specified by FileName, and is output in short integer format. One output token is produced each firing.

# GSM\_RPE\_GridPosition

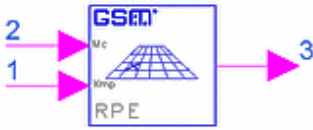

**Description:** Upsample with Zero Interpolation

**Library:** GSM, Speech Coding

**Class:** SDFGSM\_RPE\_GridPosition

## Parameters

Name	Description	Default	Unit	Type	Range
Precision	input and output precision.	16.0		precision	[2.0, $\infty$ )
NoInput	number of input samples.	13		int	[1, $\infty$ )
NoOutput	number of output samples.	40		int	[3, $\infty$ )
RatioInterpolation	ratio of interpolation.	3		int	[1, $\infty$ )

## Pin Inputs

Pin	Name	Description	Signal Type
1	Xmp	decoded RPE samples.	fix
2	Mc	grid position selection.	fix

## Pin Outputs

Pin	Name	Description	Signal Type
3	output	reconstructed long-term residual signal ep[0..39].	fix

## Notes/Equations

- This model produces a reconstructed long-term residual signal. This is an inverse transformation of GSM\_RPE\_GridSelection.  
NoInput specifies the number of input tokens; NoOutput specifies the number of output tokens each firing.
- Implementation  
This model calculates the reconstructed long-term residual signal ep[0..39] for the LTP analysis filter. Input Xmp[0..12] is upsampled by a factor of RatioInterpolation by inserting zero values. Input Mc indicates the interpolation phase.

## References

1. European Telecommunications Standard Institute (ETSI), Rec. ETSI/GSM 06.10, *Full Rate Speech Transcoding*, version 4.0.2, Sept. 1994.
2. GSM\_RPE\_GridSelection model.

# GSM\_RPE\_GridSelection



**Description:** Downsample with Energy Selection

**Library:** GSM, Speech Coding

**Class:** SDFGSM\_RPE\_GridSelection

## Parameters

Name	Description	Default	Unit	Type	Range
NoInput	number of input samples.	40		int	[3, ∞)
NoOutput	number of output samples.	13		int	[1, ∞)
Precision	input and output precision.	16.0		precision	[2.0, ∞)
RatioDecimation	ratio of decimation.	3		int	[1, ∞)

## Pin Inputs

Pin	Name	Description	Signal Type
1	input	x, weighting-filtered signal.	fix

## Pin Outputs

Pin	Name	Description	Signal Type
2	Xm	Xm, down-sampled signal with maximum energy.	fix
3	Mc	Mc, denoting which sub-sequence has maximum energy.	fix

## Notes/Equations

1. This model performs a down-sampling process. NoInput specifies the number of input tokens; NoOutput specifies the number of output tokens each firing.

2. Implementation

The weighting-filtered signal  $x$  is down-sampled by a ratio of 3, and 4 sub-sequences  $x_m$  are provided.

$$x_m(i) = x(k_j + m + 3 \times i) \quad ; \quad \begin{matrix} i = 0, \dots, 12 \\ m = 0, \dots, 3 \end{matrix}$$

where  $m$  denotes the position of the decimation grid.

The optimum candidate sub-sequence  $X_M$  is selected, which is the one with maximum energy.



$$E_M = \max \sum_{i=0}^{12} x_m^2(i); m = 0, \dots, 3$$

The optimum grid position M is coded as Mc with 2 bits.

In this model, down-sampling ratio is a parameter. It should be in accordance with:

NoOutput = int[NoInput/RatioDecimation]

where

int[x] indicates the largest integer  $\leq x$ .

Output Xm(i) can be expressed as:

$X_m(i) = x(m + \text{RatioDecimation} * i)$

where

$i = 0, \dots, \text{NoInput}-1$

$m = 0, \dots, \text{RatioDecimation} + \text{mod}(\text{NoInput}/\text{NoOutput})$ .

## References

1. European Telecommunications Standard Institute (ETSI), Rec. ETSI/GSM 06.10, *Full Rate Speech Transcoding*, version 4.0.2, Sept. 1994.
2. GSM\_RPE\_GridPosition model.



# GSM\_Schur



**Description:** Schur Recursion to Calculate Reflection Coefficients

**Library:** GSM, Speech Coding

**Class:** SDFGSM\_Schur

## Parameters

Name	Description	Default	Unit	Type	Range
InputPrecision	input precision.	32.0		precision	[2.0, ∞)
OutputPrecision	output precision.	16.0		precision	[2.0, ∞)
NoInput	number of input samples.	9		int	[2, ∞)

## Pin Inputs

Pin	Name	Description	Signal Type
1	input	L_ACF[..], values of autocorrelation function.	fix

## Pin Outputs

Pin	Name	Description	Signal Type
2	output	reflection coefficients.	fix

## Notes/Equations

- This model calculates reflection coefficients.  
Each firing, NoInput specifies the number of input tokens, the number of output tokens is 1 less than input.
- Implementation  
The reflection coefficients are calculated using Schur recursion algorithm. The term *reflection coefficients* comes from the theory of linear prediction of speech, where a vocal tract representation consisting of a series of uniform cylindrical section is assumed. Such a representation can be described by the reflection coefficients or the area ratios of connected sections.

## References

- European Telecommunications Standard Institute (ETSI), Rec. ETSI/GSM 06.10, *Full Rate Speech Transcoding*, version 4.0.2, Sept. 1994.

# GSM\_ShortTermAnalysis



**Description:** Short-Term Analysis Filter

**Library:** GSM, Speech Coding

**Class:** SDFGSM\_ShortTermAnalysis

## Parameters

Name	Description	Default	Unit	Type	Range
Precision	input and output precision.	16.0		precision	[2.0, $\infty$ )
Step1	first dividing point.	13		int	(0, $\infty$ )
Step2	second dividing point.	27		int	[Step1, $\infty$ )
Step3	third dividing point.	40		int	[Step2, $\infty$ )
BlockSize	number of input and output samples.	160		int	[Step3, $\infty$ )
Order	number of new coefficients to read each time.	8		int	(0, $\infty$ )

## Pin Inputs

Pin	Name	Description	Signal Type
1	sigIn	$S(k)$ , $k=0,1,\dots,159$ , pre-emphasized signal.	fix
2	coefs	$r'(i)$ , $i=0, \dots, 7$ , coded and interpolated reflection coefficients.	fix

## Pin Outputs

Pin	Name	Description	Signal Type
3	sigOut	$d(k)$ , $k=0,1,\dots,159$ , residual signal.	fix

## Notes/Equations

1. This model is used to obtain the short-term residual signal  $d(k)$ . BlockSize (default=160) specifies the number of sigIn and sigOut tokens each firing. The number of coefs tokens is  $\text{Order} \times 4$ .
2. Implementation  
A fixed-point lattice filter is used to obtain the short-term residual signal  $d(k)$ ; it calculates the short-term residual signal  $d[.]$  to be fed to the RPE-LTP loop from the segmented  $s[.]$  signal and from the local  $r'[.]$  array (quantized reflection coefficients). Because of segmented interpolation, the calculation is divided into four sections using different interpolated reflection coefficients. The arguments step1, step2, step3, are dividing points. These are in accordance with:  $\text{step3} \geq \text{step2} \geq \text{step1}$ .

$$d_0(k) = S(k)$$

$$u_0(k) = S(k)$$

$$d_i(k) = d_{i-1}(k) + r_i' \times u_{i-1}(k-1); i = 1, \dots, 8$$

$$u_i(k) = u_{i-1}(k-1) + r_i' \times d_{i-1}(k); i = 1, \dots, 8$$

$$d(k) = d_8(k)$$

The structure of the lattice filter is illustrated in [Short-term Analysis Filter](#).

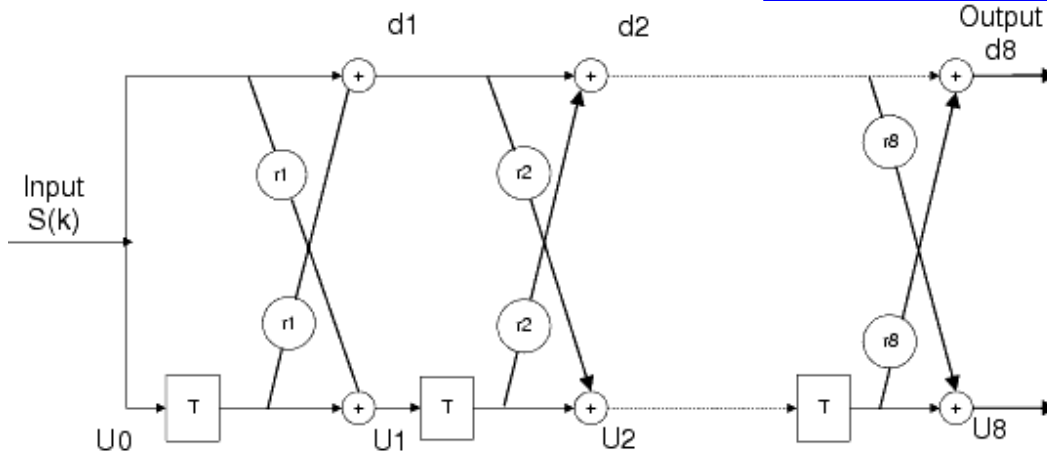

**Short-term Analysis Filter**

## References

1. European Telecommunications Standard Institute (ETSI), Rec. ETSI/GSM 06.10, *Full Rate Speech Transcoding*, version 4.0.2, Sept. 1994.
2. GSM\_ShortTermSynthesis model.

# GSM\_ShortTermPredict



**Description:** Estimate Short-Term Residual Signal.

**Library:** GSM, Speech Coding

**Class:** SDFGSM\_ShortTermPredict

## Parameters

Name	Description	Default	Unit	Type	Range
Precision	input and output precision.	16.0		precision	[2.0, ∞)
BlockSize	number of input and output per sub-frame.	40		int	[1, ∞)

## Pin Inputs

Pin	Name	Description	Signal Type
1	LTPgn	gain factor.	fix
2	LTPlag	LTP lag.	fix
3	recons	d', reconstructed short-term residual signal.	fix

## Pin Outputs

Pin	Name	Description	Signal Type
4	est	d'', estimate of the short-term residual signal.	fix

## Notes/Equations

- This model is used to decode LTP lags  $N_{cj}$ , gains  $b_{cj}$  and estimate the short-term residual signal  $d''(k)$ . This is an inverse transformation of GSM\_LTP\_Parameter. Each firing, BlockSize (default=40) specifies the number of recons and est tokens. The number of tokens for LTPgn and LTPlag are fixed to 1.
- Implementation  
The  $b_{cj}$  parameter is decoded to determine the samples of the estimate  $dpp[0..39]$ . The long-term residual signal  $e[0..39]$  is calculated to be fed to the long-term analysis filter.  
Calculation of LTP parameters is implemented as follows:
  - decode LTP Lags
  - decode LTP gains
 
$$b'_j = QLB(b_{cj}); j = 0, \dots, 3$$
  - estimate the short-term residual signal  $d''(k)$

$$d''(k_j + k) = b_j' \times d'(k_j + k - N_j'); \begin{matrix} j = 0, \dots, 3 \\ k = 0, \dots, 39 \\ k_j = k_0 + j \times 40 \end{matrix}$$

## References

1. European Telecommunications Standard Institute (ETSI), Rec. ETSI/GSM 06.10, *Full Rate Speech Transcoding*, version 4.0.2, Sept. 1994.

# GSM\_ShortTermSynthesis



**Description:** Inverse Transformation of Short-Term Analysis Filter.

**Library:** GSM, Speech Coding

**Class:** SDFGSM\_ShortTermSynthesis

## Parameters

Name	Description	Default	Unit	Type	Range
Precision	input and output precision.	16.0		precision	[2.0, $\infty$ )
BlockSize	number of input and output samples.	160		int	[Step3, $\infty$ )
Order	number of new coefficients to read each time.	8		int	(0, $\infty$ )
Step1	first dividing point.	13		int	(0, $\infty$ )
Step2	second dividing point.	27		int	[Step1, $\infty$ )
Step3	third dividing point.	40		int	[Step2, $\infty$ )

## Pin Inputs

Pin	Name	Description	Signal Type
1	sigIn	$dr'(k)$ , $k=0,1,\dots,159$ , short-term residual signal.	fix
2	coefs	decoded reflection coefficients.	fix

## Pin Outputs

Pin	Name	Description	Signal Type
3	sigOut	$Sr(k)$ , $k=0,1,\dots,159$ , output of short-term synthesis filter.	fix

## Notes/Equations

1. This model is an inverse transformation of GSM\_ShortTermAnalysis. Each firing, BlockSize (default=160) specifies the number of sigIn and sigOut tokens; the number of coefs tokens is Order $\times$ 4.
2. Implementation  
The short-term synthesis filter is implemented according to the lattice structure in [Short-Term Synthesis Filter](#).



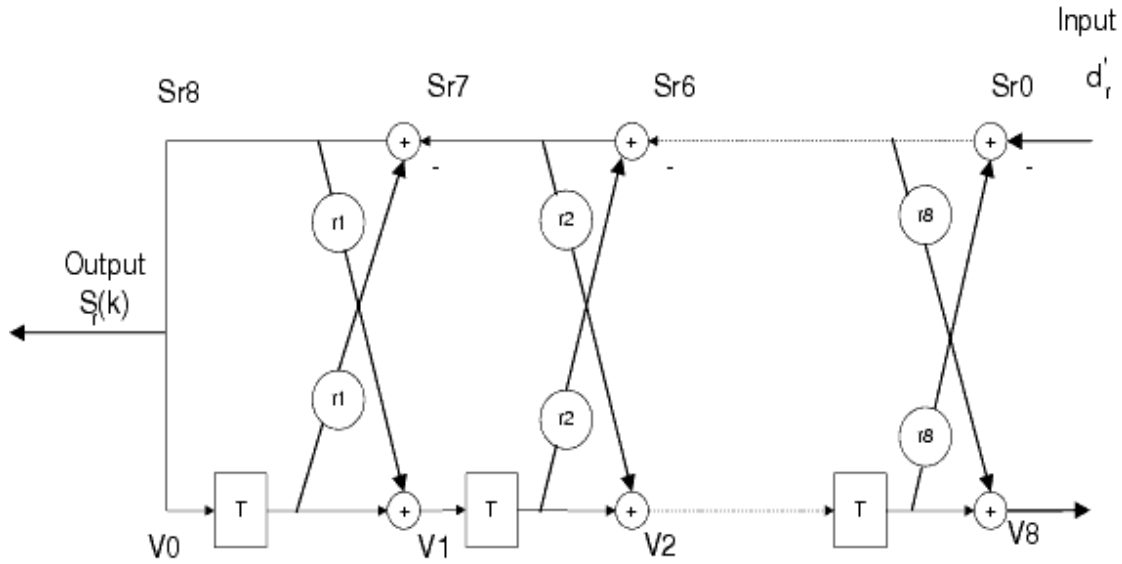

**Short-Term Synthesis Filter**

**References**

1. European Telecommunications Standard Institute (ETSI), Rec. ETSI/GSM 06.10, *Full Rate Speech Transcoding*, version 4.0.2, Sept. 1994.

# GSM\_SpeechDecoder



**Description:** GSM Speech Decoder

**Library:** GSM, Speech Coding

**Class:** SDFGSM\_SpeechDecoder

## Parameters

Name	Description	Default	Unit	Type	Range
FrameSize	speech frame length	160		int	[1, ∞)
SubFrameSize	speech sub-frame length	40		int	[1, ∞)
RPE_Ratio	upsample or downsample ratio for RPE	3		int	[1, ∞)

## Pin Inputs

Pin	Name	Description	Signal Type
1	input	frame data packet(260 bits per 20 msec)	int

## Pin Outputs

Pin	Name	Description	Signal Type
2	output	reconstructed speech signal	fix

## Notes/Equations

1. This subnetwork is applicable for the full-rate traffic channel (TCH) in the Pan-European Digital Mobile Radio (DMR) system.

2. Implementation

This subnetwork takes encoded blocks of 260 bits as input. The output is reconstructed 160 speech samples in 13-bit uniform PCM format. The output sampling rate is 8000 samples/sec. The coding scheme is called regular pulse excitation-long term prediction-linear predictive coder (RPE-LTP).

The RPE-LTP decoder block diagram is shown in [RPE\\_LTP Decoder Block Diagram](#). The decoder includes the same structure as the feed-back loop of the encoder. In error-free transmission, the output of this stage will be the reconstructed short-term synthesis filter followed by the de-emphasis filter, which results in the reconstructed speech signal samples.

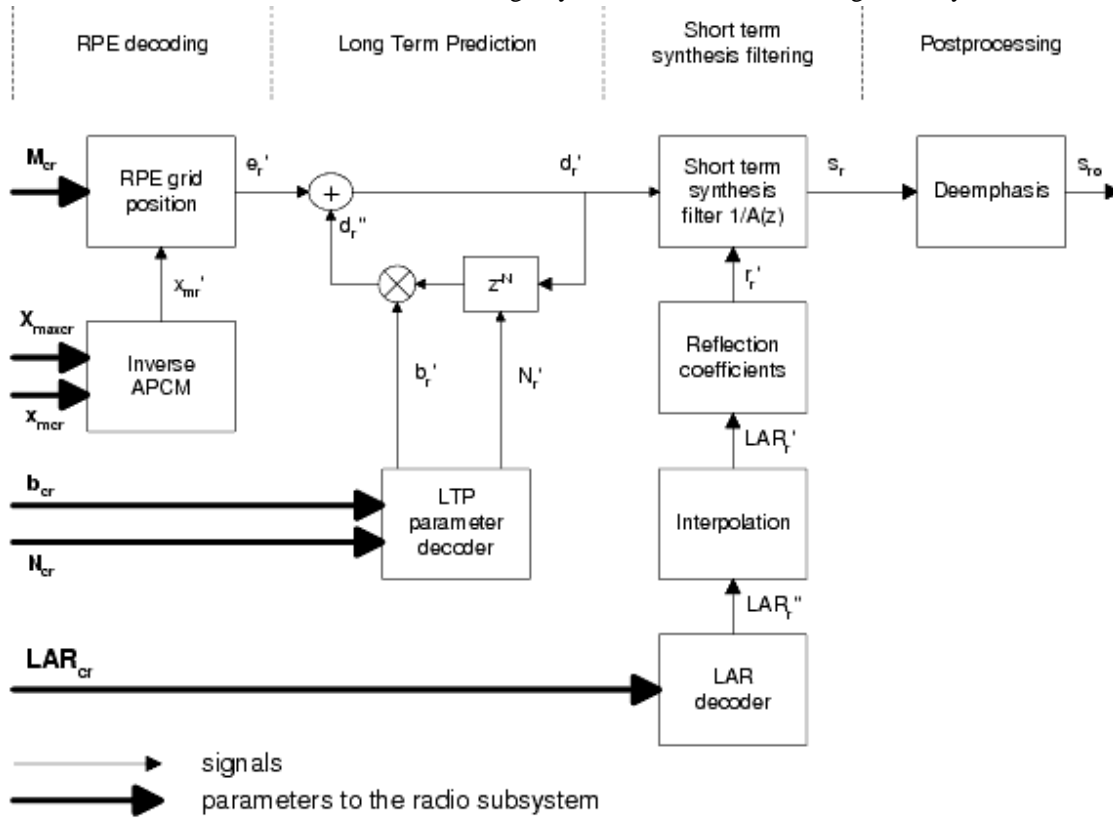

RPE\_LTP Decoder Block Diagram

References

1. European Telecommunications Standard Institute (ETSI), Rec. ETSI/GSM 06.10, *Full Rate Speech Transcoding*, version 4.0.2, Sept. 1994.
2. GSM\_SpeechEncoder model.

# GSM\_SpeechEncoder



**Description:** GSM Speech Encoder

**Library:** GSM, Speech Coding

**Class:** SDFGSM\_SpeechEncoder

## Parameters

Name	Description	Default	Unit	Type	Range
FrameSize	speech frame length	160		int	[1, ∞)
SubFrameSize	speech sub-frame length	40		int	[1, ∞)
RPE_Ratio	upsample or downsample ratio for regular pulse excitation	3		int	[1, ∞) RPE_Ratio=[SubFrameSize/13]

## Pin Inputs

Pin	Name	Description	Signal Type
1	input	13-bit uniform PCM speech signal	fix

## Pin Outputs

Pin	Name	Description	Signal Type
2	output	frame data packet (260 bits per 20 msec)	int

## Notes/Equations

- GSM\_SpeechEncoder is applicable for the full-rate traffic channel (TCH) in the Pan-European Digital Mobile Radio (DMR) system.
- Implementation
 

This subnetwork takes 160 speech samples in 13-bit uniform PCM format as input. The output is encoded blocks of 260 bits. The sampling rate is 8000 samples/sec leading to an average bit rate for the encoded bit stream of 13 kbit/sec. The coding scheme is called regular pulse excitation-long term prediction-linear predictive coder (RPE-LTP).

The RPE-LTP encoder block diagram is shown in [RPE-LTP Encoder Block Diagram](#). The input speech frame, consisting of 160 signal samples (uniform 13-bit PCM samples), is pre-processed to produce an offset-free signal that is then subjected to a first-order pre-emphasis filter. The 160 samples obtained are analyzed to determine the coefficients for the short-term analysis filter (LPC filter). Then these parameters are used for the filtering of the same 160 samples. The result is 160 samples of the short-term residual signal. The filter parameters, termed reflection coefficients, are

transformed to Log.area ratios (LARs) before transmission.

For the following operations, the speech frame is divided into four sub-frames with 40 samples of short-term residual signal in each. Each sub-frame is processed blockwise by the subsequent functional elements.

Before processing each sub-block of 40 short-term residual samples, the parameters of the long-term analysis filter, LTP lag, and LTP gain are estimated and updated in the LTP analysis block; this is done based on the current sub-block of the present and a stored sequence of the 120 previous reconstructed short-term residual samples.

A block of 40 long-term residual signal samples is obtained by subtracting 40 estimates of the short-term residual signal from the short-term residual signal itself. The resulting block of 40 long-term residual samples is fed to the RPE analysis, which performs the basic compression function of the algorithm.

As a result of the RPE-analysis, the 40 long-term residual samples input block is represented by one of 4 candidate sub-sequences of 13 pulses each. The sub-sequence selected is identified by the RPE grid position (M). The 13 RPE pulse are encoded using adaptive pulse code modulation (APCM) with estimation of the sub-block amplitude, which is transmitted to the decoder as side information.

The RPE parameters are also fed to a local RPE decoding and reconstruction model, which produces a block of 40 samples of the quantized version of the long-term residual signal.

By adding these 40 quantized samples of the long-term residual to the previous block of short-term residual signal estimates, a reconstructed version of the current short-term residual signal is obtained.

Then the block of reconstructed short-term residual signal samples is fed to the long-term analysis filter, which produces the new block of 40 short-term residual signal estimates to be used for the next sub-block, thereby completing the feedback loop.

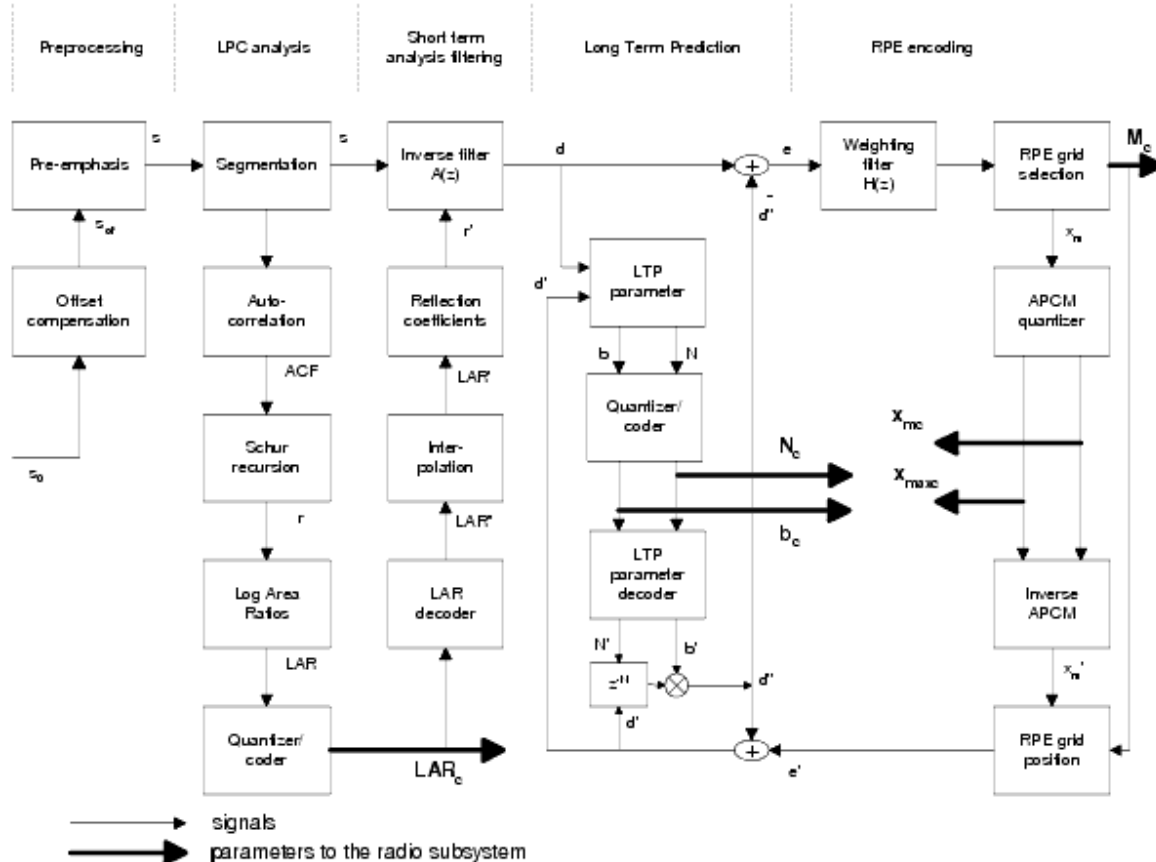

## RPE-LTP Encoder Block Diagram

### References

1. European Telecommunications Standard Institute (ETSI), Rec. ETSI/GSM 06.10, *Full Rate Speech Transcoding*, version 4.0.2, Sept. 1994.
2. GSM\_SpeechDecoder model.

# GSM\_WeightingFilter

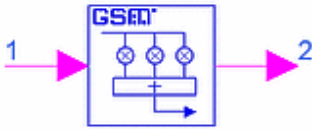

**Description:** Sub-Segment Weighting Filter

**Library:** GSM, Speech Coding

**Class:** SDFGSM\_WeightingFilter

## Parameters

Name	Description	Default	Unit	Type	Range
Precision	input and output precision.	16.0		precision	[2.0, $\infty$ )
BlockSize	number of input and output samples per sub-frame.	40		int	[1, $\infty$ )

## Pin Inputs

Pin	Name	Description	Signal Type
1	input	$e(k)$ , long-term residual signal.	fix

## Pin Outputs

Pin	Name	Description	Signal Type
2	output	$x(k)$ , weighting filtered signal.	fix

## Notes/Equations

- This model is the weighting filter used in RPE encoding.  
Each firing, BlockSize input tokens are consumed and BlockSize output tokens are produced.
- Implementation  
An FIR block filter algorithm is applied to each sub-segment by convolving BlockSize samples  $e(k)$  with impulse response  $H(i)$ ,  $i=0, \dots, 10$ ; refer to *Impulse Response of Block (Weighting) Filter*. The conventional convolution of a sequence having 40 samples with an 11-tap impulse response would produce  $\text{BlockSize}+11-1$  samples. In contrast, the block filter algorithm produces the BlockSize central samples of the conventional convolution operation. For notation convenience, the block-filtered version of each sub-segment is denoted by  $x(k)$ ,  $k=0, \dots, \text{BlockSize} - 1$  (BlockSize default=40).

$$x(k) = \sum_{i=0}^{10} H(i) \times e(k+5-i); k = 0, \dots, 39$$

$$e(k+5-i) = 0; \text{for } k+5-i < 0 \text{ and } k+5-i > 39$$

i	5	4(6)	3(7)	2(8)	1(9)	0(10)
$H(i) \times 2^{13}$	8192	5741	2054	0	-374	-134

## References

1. European Telecommunications Standard Institute (ETSI), Rec. ETSI/GSM 06.10, *Full Rate Speech Transcoding*, version 4.0.2, Sept. 1994.



# GSM\_WriteFile



**Description:** Write Data to a Binary File

**Library:** GSM, Speech Coding

**Class:** SDFGSM\_WriteFile

## Parameters

Name	Description	Default	Unit	Type	Range
FileName	output wav file name.	output.wav		filename	
FileType	file type: dos_type, unix_type	dos_type		enum	

## Pin Inputs

Pin	Name	Description	Signal Type
1	input	decoder output	int

## Notes/Equations

1. This model is used to demonstrate and test speech codec. It receives short integer data and saves the data in a binary file. Each firing, one input token is consumed.
2. For FileType: select dos\_type for PC platforms (Windows and Linux); select unix\_type for (HP and Sun) UNIX platforms.

# Synchronization Components for GSM Design Library

- *GSM DataSelection* (gsm)
- *GSM PhaseRecovery* (gsm)
- *GSM PhsRcvryTrNoMod* (gsm)
- *GSM Sampler* (gsm)
- *GSM SynABurst* (gsm)
- *GSM SynNBurst* (gsm)
- *GSM SynNBurstTrNoMod* (gsm)
- *GSM SynSBurst* (gsm)
- *GSM TrainBitGen* (gsm)

# GSM\_DataSelection



**Description:** Selection of Middle Training Sequence

**Library:** GSM, Synchronization

**Class:** SDFGSM\_DataSelection

## Parameters

Name	Description	Default	Unit	Type	Range
SampleRate	number of samples in one bit interval: SampleRate4, SampleRate8, SampleRate16, SampleRate1	SampleRate16		enum	
BurstType	burst type: NBurst, SBurst, ABurst	NBurst		enum	
InputOrLocal	source of training sequence: Input, Local	Input		enum	

## Pin Inputs

Pin	Name	Description	Signal Type
1	input	156*SampleRate input modulated data	anytype

## Pin Outputs

Pin	Name	Description	Signal Type
2	output	selected data	anytype

## Notes/Equations

1. This model is used to select the middle bits of training sequence from modulated normal burst. Number of effective Training Sequence(N)  $\times$  SampleRate output tokens are produced for each input set of tokens consumed. Refer to the [Input Tokens Based on InputOrLocal Parameter Setting](#) and [Output Tokens Based on InputOrLocal Parameter Setting](#) for input and output token information.

### Input Tokens Based on InputOrLocal Parameter Setting

InputOrLocal Setting	NBurst	SBurst	ABurst
Input	$156 \times \text{SampleRate}$	$156 \times \text{SampleRate}$	$156 \times \text{SampleRate}$
Local	$26 \times \text{SampleRate}$	$64 \times \text{SampleRate}$	$41 \times \text{SampleRate}$

### Output Tokens Based on InputOrLocal Parameter Setting

<b>InputOrLocal Setting</b>	<b>NBurst</b>	<b>SBurst</b>	<b>ABurst</b>
Input or Local	$16 \times \text{SampleRate}$	$54 \times \text{SampleRate}$	$31 \times \text{SampleRate}$

## 2. Implementation

If InputOrLocal=Local, the model will select the middle  $N \times \text{SampleRate}$  bits from local modulated training sequence. Otherwise, the model will select the middle  $N \times \text{SampleRate}$  bits of training sequence from  $156 \times \text{SampleRate}$  input data. SampleRate=1 means the training sequence is not modulated, the InputOrLocal parameter must be set to Local.

## References

1. European Telecommunications Standard Institute (ETSI), Rec. ETSI/GSM 05.02, *Multiplexing and Multiple Access on the Radio Path*, version 3.5.1, March 1992.
2. European Telecommunications Standard Institute (ETSI), Rec. ETSI/GSM 03.03, *Numbering, addressing and identification*, version 3.5.1, March 1992.
3. European Telecommunications Standard Institute (ETSI), Rec. ETSI/GSM 04.03, *Mobile Station - Base Station System (MS - BSS) interface Channel structures and access capabilities*, version 3.5.1, March 1992.

# GSM\_PhaseRecovery



**Description:** Index of Sequence with Peak Correlation Value

**Library:** GSM, Synchronization

**Class:** SDFGSM\_PhaseRecovery

## Parameters

Name	Description	Default	Unit	Type	Range
SampleRate	number of samples in one bit interval: SampleRate4, SampleRate8, SampleRate16	SampleRate16		enum	
BurstType	burst type: NBurst, SBurst, ABurst	NBurst		enum	

## Pin Inputs

Pin	Name	Description	Signal Type
1	ref	reference local data	complex
2	input	data to be synchronized	complex

## Pin Outputs

Pin	Name	Description	Signal Type
3	index	index of sampling data	int

## Notes/Equations

1. This model correlates the received modulated training sequence and the local modulated training sequence to estimate the timing offset and provide carrier phase reference for further use. Each firing, one token is produced per input set of tokens;  $16 \times \text{SampleRate}$  ref tokens are consumed;  $16 \times \text{SampleRate}$  input tokens are consumed.

## References

1. G. D'Aria, F. Muratore, *Simulation and Performance of the Pan-European Land Mobile Radio System*, IEEE Trans. on Vehicular Technology, Vol. 41, pp. 177-189, No.2, May 1992.

# GSM\_PhsRcvryTrNoMod

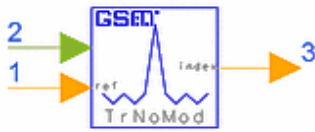

**Description:** Index of Sequence with Peak Correlation Value (Training Bits Not Modulated)

**Library:** GSM, Synchronization

**Class:** SDFGSM\_PhsRcvryTrNoMod

## Parameters

Name	Description	Default	Unit	Type	Range
SampleRate	number of samples in one bit interval: SampleRate4, SampleRate8, SampleRate16	SampleRate16		enum	

## Pin Inputs

Pin	Name	Description	Signal Type
1	ref	reference local training sequence	int
2	input	data to be synchronized	complex

## Pin Outputs

Pin	Name	Description	Signal Type
3	index	index of sampling data	int

## Notes/Equations

- This model is used to correlate the received modulated training sequence and the local training sequence, which is not modulated, to estimate the timing offset and provide the carrier phase reference for use later. One token is produced for each set of input tokens;  
 ref = SampleRate input tokens are consumed each firing;  
 input =  $16 \times$  SampleRate input tokens are consumed each firing.

## References

- G. D'Aria, F. Muratore, *Simulation and Performance of the Pan-European Land Mobile Radio System*, IEEE Trans. on Vehicular Technology, Vol. 41, May 1992, pp. 177-189.

# GSM\_Sampler



**Description:** Sample Input and Output Sequence with One Sample per Symbol

**Library:** GSM, Synchronization

**Class:** SDFGSM\_Sampler

## Parameters

Name	Description	Default	Unit	Type	Range
SampleRate	number of samples in one bit interval: SampleRate4, SampleRate8, SampleRate16	SampleRate16		enum	

## Pin Inputs

Pin	Name	Description	Signal Type
1	index	index of sample point to be output	int
2	input	oversampled data	complex

## Pin Outputs

Pin	Name	Description	Signal Type
3	output	synchronized data	complex

## Notes/Equations

1. This model is used to select one of the oversampled input sequences to output the sequence of 156 sample points with one sample per symbol. 156 output tokens are produced for each set of input tokens consumed. One index token is consumed each firing.  $\text{SampleRate} \times 156$  input tokens are consumed each firing.
2. Implementation  
After  $\text{SampleRate} \times 156$  sample points are received, the model divides them into SampleRate sequences; all first sample points of each symbol construct the first sequence, all second sample points of each symbol construct the second sequence, and so on. After the model receives input index, it selects one of the sequences and output.

## References

1. G. D'Aria, F. Muratore, *Simulation and Performance of the Pan-European Land Mobile*





# GSM\_SynABurst



**Description:** Bit Synchronization for Access Burst

**Library:** GSM, Synchronization

**Class:** SDFGSM\_SynABurst

## Parameters

Name	Description	Default	Unit	Type	Range
SampleRate	sample rate of modulated data per bit: SampleRate 4, SampleRate 8, SampleRate 16	SampleRate 16		enum	

## Pin Inputs

Pin	Name	Description	Signal Type
1	input	156XSampleRate modulated bits	complex

## Pin Outputs

Pin	Name	Description	Signal Type
2	output	156 synchronized and down-sampled bits	complex

## Notes/Equations

1. This subnetwork is used to implement bit synchronization for access burst before GSM MLSE receiver.
2. Implementation  
[GSM\\_SynABurst Subnetwork](#) shows the subnetwork structure. The SampleRate parameter in all models must be the same as subnetwork SampleRate parameters. The oversampled received training sequence and the local modulated training sequence are selected separately by two data selection models. GSM\_PhaseRecovery uses these two sequences to obtain the optimum sampling index; this index is used by GSM\_Sampler to produce the output samples with one sample per symbol.

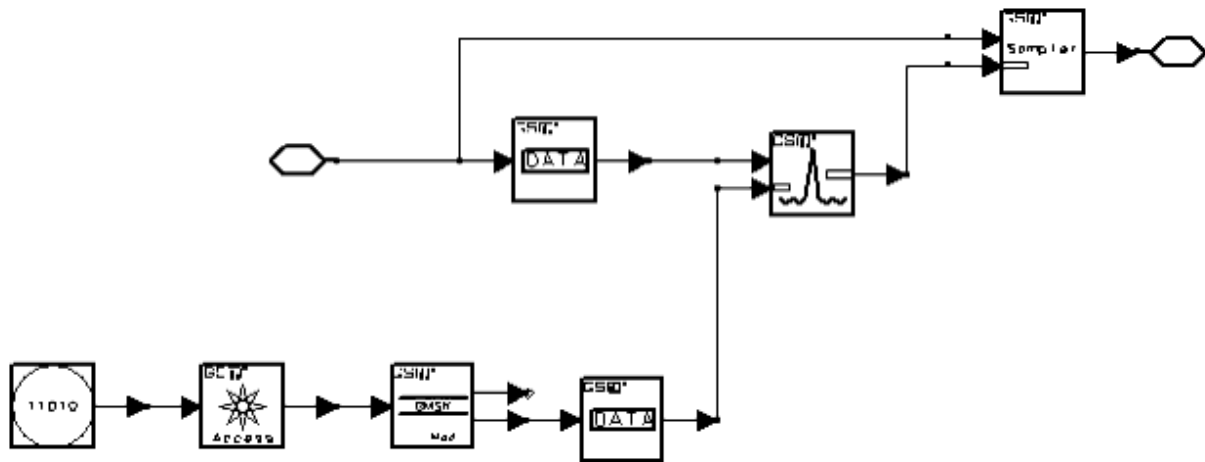

### GSM\_SynABurst Subnetwork

### References

1. European Telecommunications Standard Institute (ETSI), Rec. ETSI/GSM 05.02, *Multiplexing and Multiple Access on the Radio Path*, version 3.5.1, March 1992.
2. European Telecommunications Standard Institute (ETSI), Rec. ETSI/GSM 03.03, *Numbering, addressing and identification*, version 3.5.1, March 1992.
3. European Telecommunications Standard Institute (ETSI), Rec. ETSI/GSM 04.03, *Mobile Station - Base Station System (MS - BSS) interface Channel structures and access capabilities*, version 3.5.1, March 1992.

# GSM\_SynNBurst



**Description:** Bit Synchronization for Normal Burst

**Library:** GSM, Synchronization

**Class:** SDFGSM\_SynNBurst

## Parameters

Name	Description	Default	Unit	Type	Range
SampleRate	sample rate of modulated data per bit: SampleRate 4, SampleRate 8, SampleRate 16	SampleRate 16		enum	
TSCValue	training sequence code (integer ranges from 0 to 7)	0		int	

## Pin Inputs

Pin	Name	Description	Signal Type
1	input	156XSampleRate modulated bits	complex

## Pin Outputs

Pin	Name	Description	Signal Type
2	output	156 synchronized and down-sampled bits	complex

## Notes/Equations

1. This subnetwork is used to implement bit synchronization for normal burst before GSM MLSE receiver.
2. Implementation  
[GSM\\_SynNBurst Subnetwork](#) shows the subnetwork structure. The SampleRate parameter in all models must equal the subnetwork SampleRate parameter. The oversampled received training sequence and the local modulated training sequence are selected separately by two data selection models. GSM\_PhaseRecovery uses these two sequences to obtain the optimum sampling index; this index is used by GSM\_Sampler to produce the output samples with one sample per symbol.

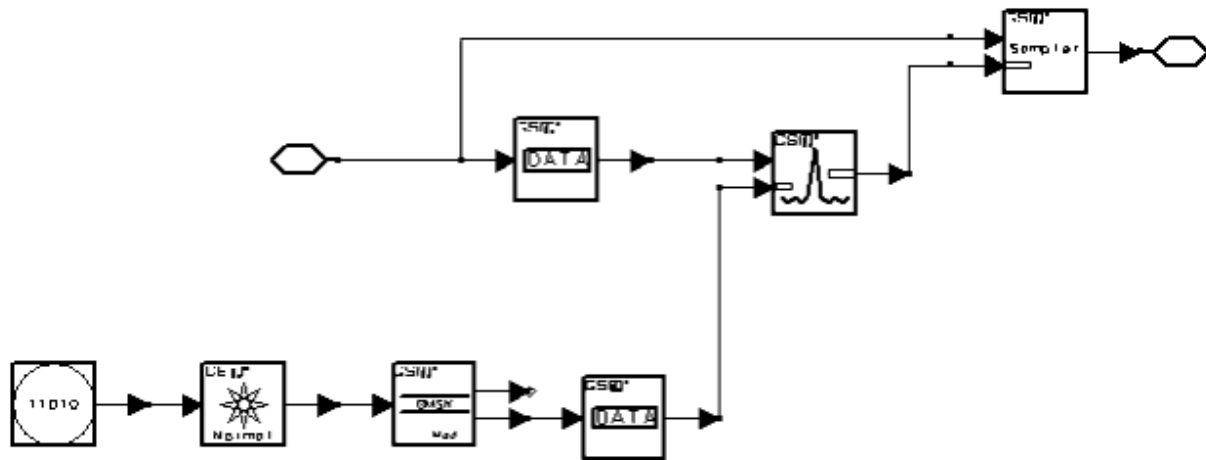

### GSM\_SynNBurst Subnetwork

### References

1. European Telecommunications Standard Institute (ETSI), Rec. ETSI/GSM 05.02, *Multiplexing and Multiple Access on the Radio Path*, version 3.5.1, March 1992.
2. European Telecommunications Standard Institute (ETSI), Rec. ETSI/GSM 03.03, *Numbering, addressing and identification*, version 3.5.1, March 1992.
3. European Telecommunications Standard Institute (ETSI), Rec. ETSI/GSM 04.03, *Mobile Station - Base Station System (MS - BSS) interface Channel structures and access capabilities*, version 3.5.1, March 1992.

## GSM\_SynNBurstTrNoMod



**Description:** Bit Synchronization for Normal Burst (Training Sequence Not Modulated)

**Library:** GSM, Synchronization

**Class:** SDFGSM\_SynNBurstTrNoMod

### Parameters

Name	Description	Default	Unit	Type	Range
SampleRate	sample rate of modulated data per bit: SampleRate 4, SampleRate 8, SampleRate 16	SampleRate 16		enum	
TSCValue	training sequence code (integer ranges from 0 to 7)	0		int	

### Pin Inputs

Pin	Name	Description	Signal Type
1	input	156XSampleRate modulated bits	complex

### Pin Outputs

Pin	Name	Description	Signal Type
2	output	156 synchronized and down-sampled bits	complex

### Notes/Equations

1. This subnetwork is used to implement bit synchronization for normal burst before GSM MLSE receiver.
2. Implementation  
This subnetwork performs the same function as GSM\_SynNBurst, except the local sequence is not modulated before it correlates with the received sequence. [GSM\\_SynNBurstTrNoMod Subnetwork](#) shows the subnetwork structure. The SampleRate parameter in all models must equal the subnetwork SampleRate parameter.

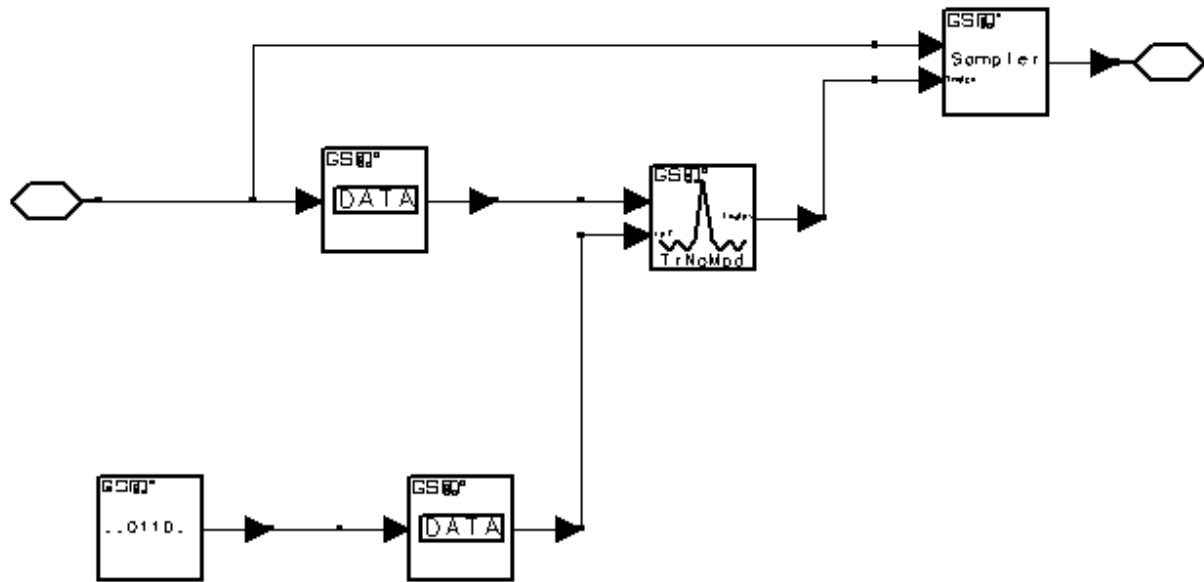

**GSM\_SynNBurstTrNoMod Subnetwork**

## References

1. European Telecommunications Standard Institute (ETSI), Rec. ETSI/GSM 05.02, *Multiplexing and Multiple Access on the Radio Path*, version 3.5.1, March 1992.
2. European Telecommunications Standard Institute (ETSI), Rec. ETSI/GSM 03.03, *Numbering, addressing and identification*, version 3.5.1, March 1992.
3. European Telecommunications Standard Institute (ETSI), Rec. ETSI/GSM 04.03, *Mobile Station - Base Station System (MS - BSS) interface Channel structures and access capabilities*, version 3.5.1, March 1992.

# GSM\_SynSBurst



**Description:** Bit Synchronization for Synchronization Burst

**Library:** GSM, Synchronization

**Class:** SDFGSM\_SynSBurst

## Parameters

Name	Description	Default	Unit	Type	Range
SampleRate	sample rate of modulated data per bit: SampleRate 4, SampleRate 8, SampleRate 16	SampleRate 16		enum	

## Pin Inputs

Pin	Name	Description	Signal Type
1	input	156XSampleRate modulated bits	complex

## Pin Outputs

Pin	Name	Description	Signal Type
2	output	156 synchronized and down-sampled bits	complex

## Notes/Equations

1. This subnetwork is used to implement bit synchronization for synchronization burst before GSM MLSE receiver.

2. Implementation

[GSM\\_SynSBurst Subnetwork](#) shows the subnetwork structure. The SampleRate parameter in all models must equal the subnetwork SampleRate parameter. The oversampled received training sequence and the local modulated training sequence are selected separately by two data selection models. GSM\_PhaseRecovery uses these two sequences to obtain the optimum sampling index; this index is used by GSM\_Sampler to produce the output samples with one sample per symbol.

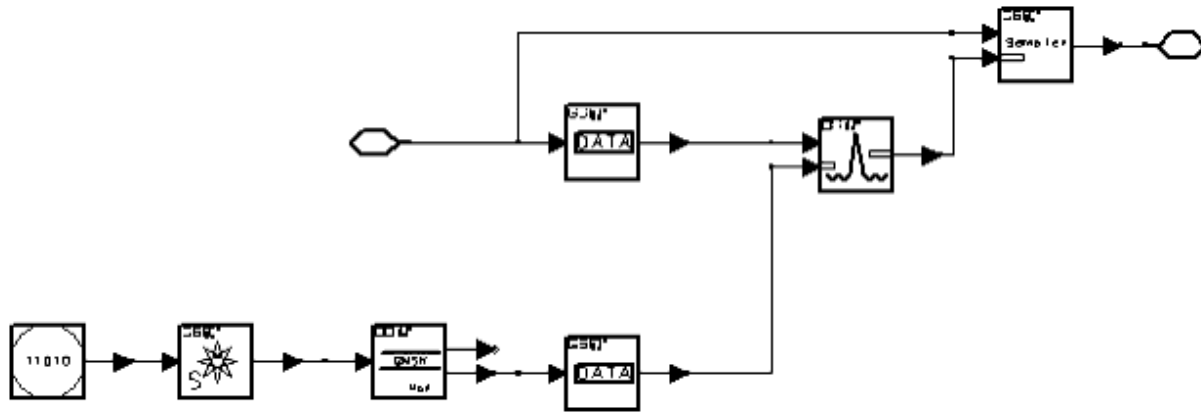

### GSM\_SynSBurst Subnetwork

### References

1. European Telecommunications Standard Institute (ETSI), Rec. ETSI/GSM 05.02, *Multiplexing and Multiple Access on the Radio Path*, version 3.5.1, March 1992.
2. European Telecommunications Standard Institute (ETSI), Rec. ETSI/GSM 03.03, *Numbering, addressing and identification*, version 3.5.1, March 1992.
3. European Telecommunications Standard Institute (ETSI), Rec. ETSI/GSM 04.03, *Mobile Station - Base Station System (MS - BSS) interface Channel structures and access capabilities*, version 3.5.1, March 1992.



# GSM\_TrainBitGen



**Description:** Training Bits Generation

**Library:** GSM, Synchronization

**Class:** SDFGSM\_TrainBitGen

## Parameters

Name	Description	Default	Unit	Type	Range
BurstType	burst type: NBurst, SBurst, ABurst	NBurst		enum	
TSC	training sequence code	0		int	[0:7]

## Pin Outputs

Pin	Name	Description	Signal Type
1	output	training sequence	int

## Notes/Equations

- This model is used to generate training sequences.  
 BurstType=NBurst, 26 tokens are produced.  
 BurstType=ABurst, 41 output tokens are produced.  
 BurstType=SBurst, 64 output tokens are produced.
- Implementation  
[TSC and Training Sequences](#) shows the training sequence output according to TSC.  
 TSC is ignored when BurstType=ABurst or SBurst.  
 The synchronization burst synchronization sequence is:  
 {1,0,1,1,1,0,0,1,0,1,1,0,0,0,1,0,0,0,0,0,0,1,0,0,0,0,0,0,1,1,1,1,0,0,1,0,1,1,0,1,  
 0,1,0,0,0,1,0,1,0,1, 1,1,0,1,1,0,0,0,0,1,1,0,1,1}  
 The access burst synchronization sequence is:  
 {0,1,0,0,1,0,1,1,0,1,1,1,1,1,1,1,1,0,0,1,1,0,0,1,1,0,1,0,1,0,1,0,0,0,1,1,1,1,0,0,0}

## TSC and Training Sequences

TSC=	Training Sequence
0	0,0,1,0,0,1,0,1,1,1,0,0,0,0,1,0,0,0,1,0,0,1,0,0,1,0,1,1,1
1	0,0,1,0,1,1,0,1,1,1,0,1,1,1,0,0,0,1,0,1,1,0,1,1,1
2	0,1,0,0,0,0,1,1,1,0,1,1,1,0,1,0,0,1,0,0,0,0,1,1,1,0
3	0,1,0,0,0,1,1,1,1,0,1,1,0,1,0,0,0,1,0,0,0,1,1,1,1,0
4	0,0,0,1,1,0,1,0,1,1,1,0,0,1,0,0,0,0,0,1,1,0,1,0,1,1
5	0,1,0,0,1,1,1,0,1,0,1,1,0,0,0,0,0,1,0,0,1,1,1,0,1,0
6	1,0,1,0,0,1,1,1,1,0,1,1,0,0,0,1,0,1,0,0,1,1,1,1,1
7	1,1,1,0,1,1,1,1,0,0,0,1,0,0,1,0,1,1,1,0,1,1,1,1,0,0

## References

1. European Telecommunications Standard Institute (ETSI), Rec. ETSI/GSM 05.02, *Multiplexing and Multiple Access on the Radio Path*, version 3.5.1, March 1992.
2. European Telecommunications Standard Institute (ETSI), Rec. ETSI/GSM 03.03, *Numbering, addressing and identification*, version 3.5.1, March 1992.
3. European Telecommunications Standard Institute (ETSI), Rec. ETSI/GSM 04.03, *Mobile Station - Base Station System (MS - BSS) interface Channel structures and access capabilities*, version 3.5.1, March 1992.